



DANGER

Danger of electrical shock, burns or death. Always remove all power sources before attempting any repair, service or diagnostic work. Power can be present from shore power, generator, inverter or battery. All power sources must be disabled and secured before performing any service.



CAUTION

If you lack the skills, tools or equipment to perform diagnostic or repair work leave such work to an authorized Winnebago Industries dealer or other qualified shop.

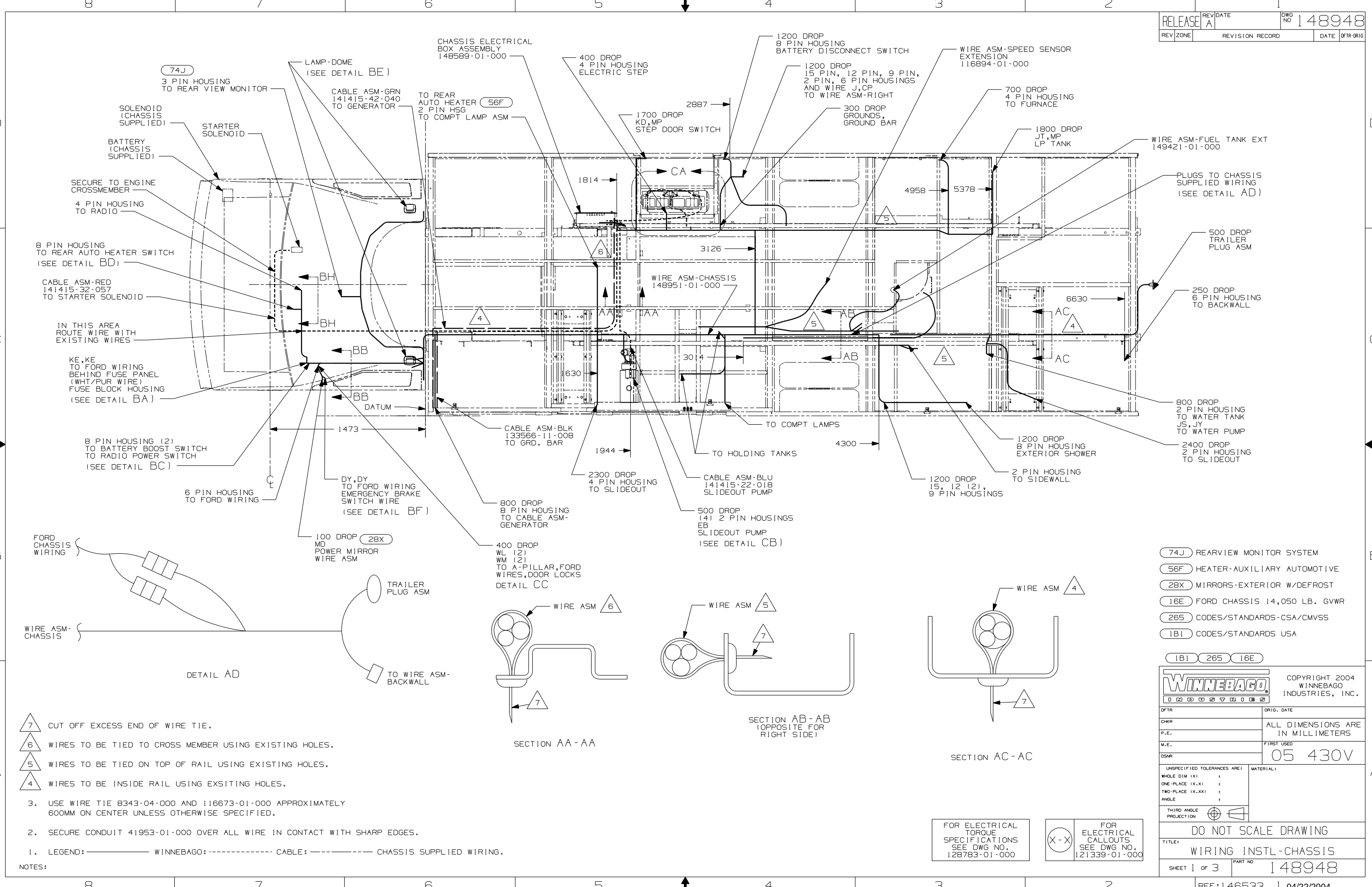

- (74J) REARVIEW MONITOR SYSTEM
- (56F) HEATER-AUXILIARY AUTOMOTIVE
- (28X) MIRRORS-EXTERIOR W/DEFROST
- (16E) FORD CHASSIS 14,050 LB. GVWR
- (265) CODES/STANDARDS-CSA/CMVSS
- (1B1) CODES/STANDARDS USA

1B1 265 16E

WINNEBAGO COPYRIGHT 2004 WINNEBAGO INDUSTRIES, INC.

DFTR	ORIG. DATE
CHKR	ALL DIMENSIONS ARE IN MILLIMETERS
P.E.	
M.E.	FIRST USED
DSNR	05 430V
UNSPECIFIED TOLERANCES ARE:	MATERIAL:
HOLE DIM (X)	:
ONE-PLACE (X.X)	:
TWO-PLACE (X.XX)	:
ANGLE	:
THIRD ANGLE PROJECTION	

DO NOT SCALE DRAWING

TITLE: WIRING INSTL-CHASSIS

SHEET 1 of 3 PART NO 148948

REF: 146533 1 04/22/2004

- 7 CUT OFF EXCESS END OF WIRE TIE.
- 6 WIRES TO BE TIED TO CROSS MEMBER USING EXISTING HOLES.
- 5 WIRES TO BE TIED ON TOP OF RAIL USING EXISTING HOLES.
- 4 WIRES TO BE INSIDE RAIL USING EXISTING HOLES.

3. USE WIRE TIE 8343-04-000 AND 116673-01-000 APPROXIMATELY 600MM ON CENTER UNLESS OTHERWISE SPECIFIED.
2. SECURE CONDUIT 41953-01-000 OVER ALL WIRE IN CONTACT WITH SHARP EDGES.
1. LEGEND: — WINNEBAGO: - - - - - CABLE: - - - - - CHASSIS SUPPLIED WIRING.

FOR ELECTRICAL TORQUE SPECIFICATIONS SEE DWG NO. 128783-01-000

(X-X) FOR ELECTRICAL CALLOUTS SEE DWG NO. 121339-01-000

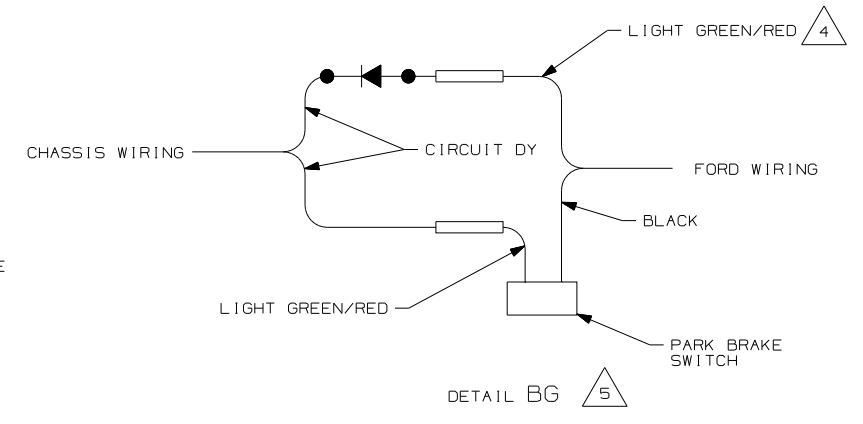
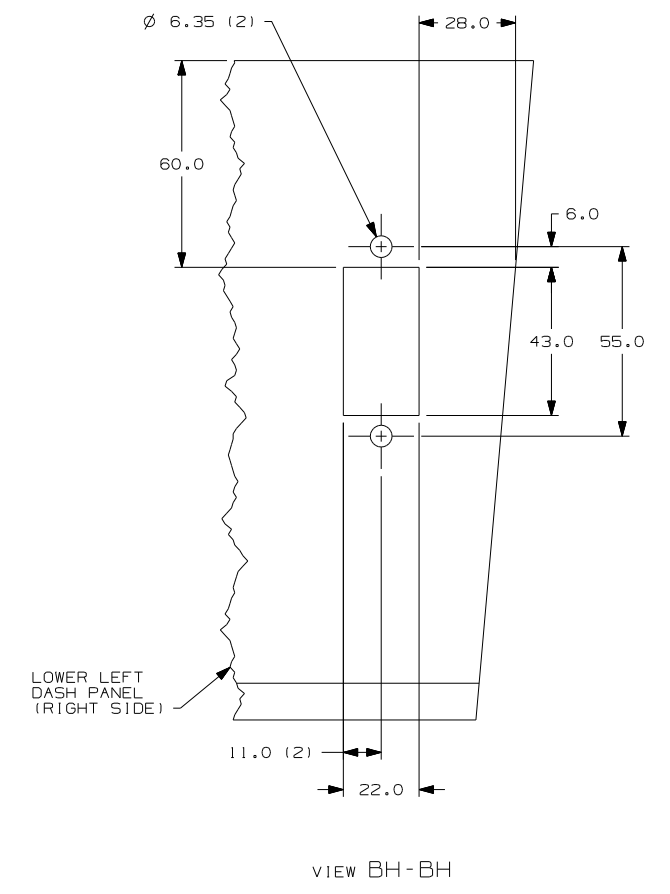
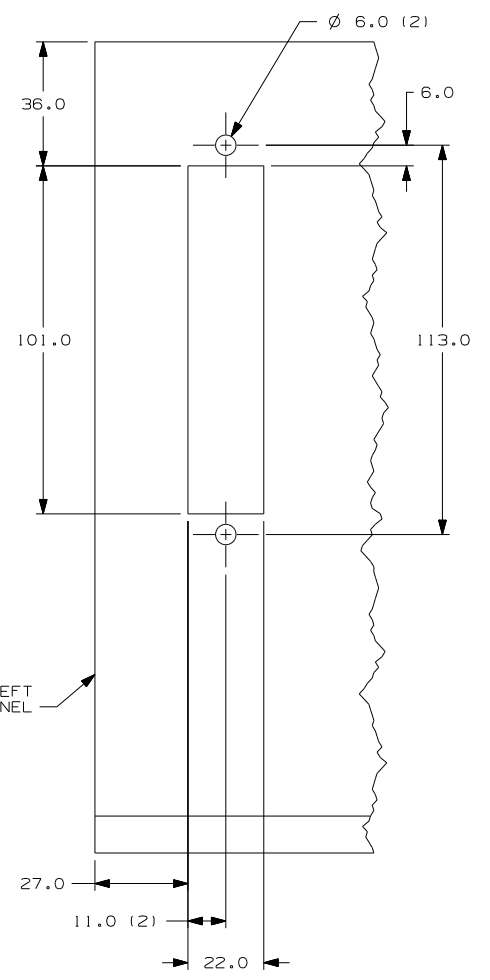
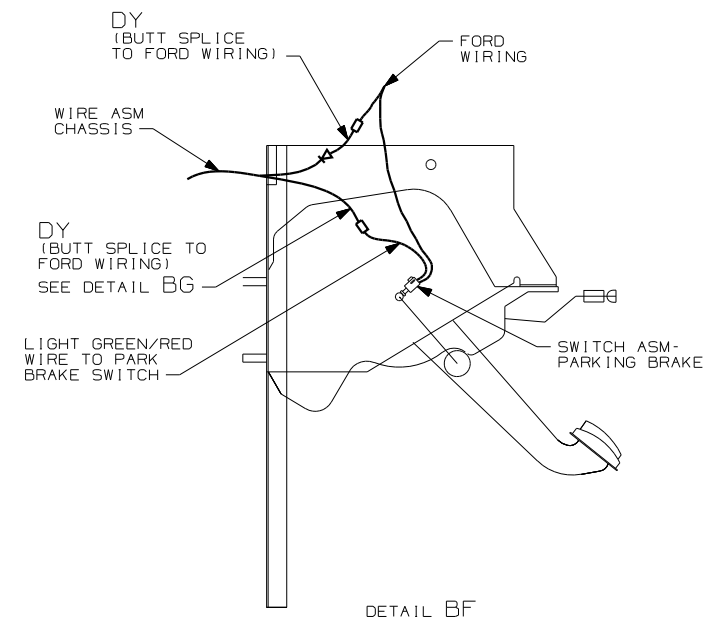
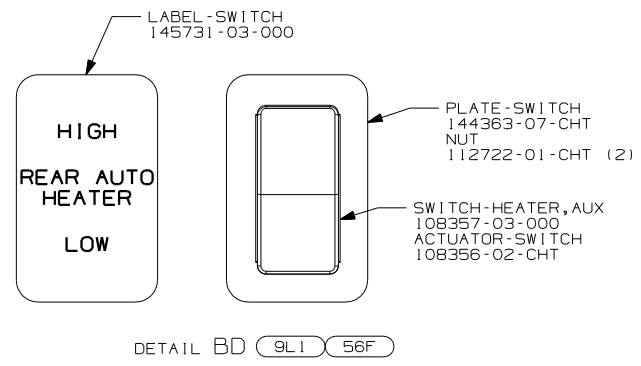
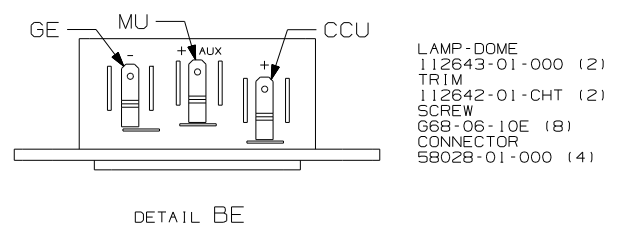
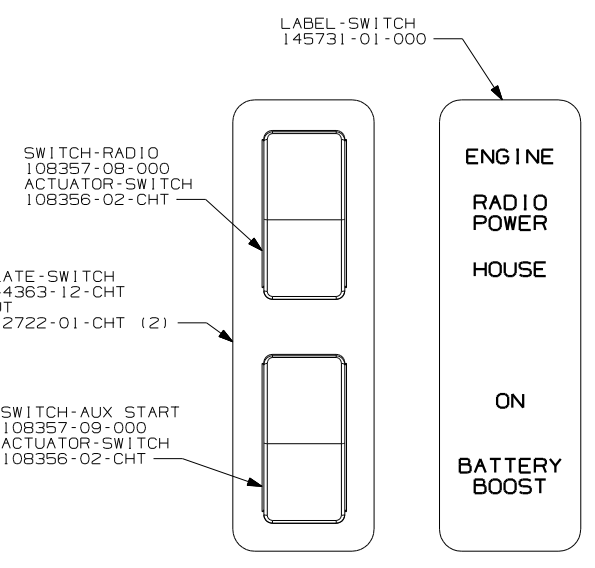
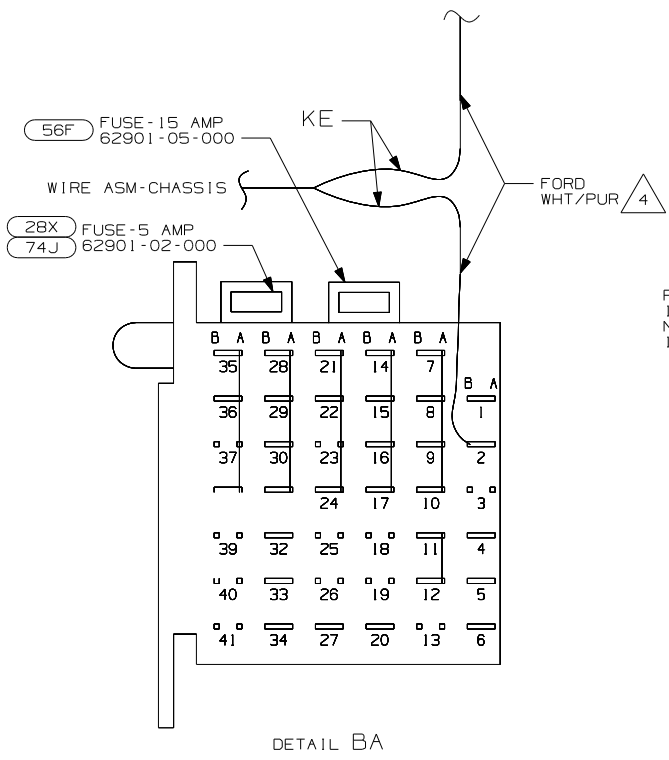

- NOTES:
1. ALL WIRES TO BE SECURED WITH CLAMP 10495-01-000 OR CLIP 80734-01-000 EVERY 600MM. USE SCREW 667-10-12B UNLESS OTHERWISE SPECIFIED.
 2. ALL 110V WIRE TO BE CLAMPED WITH CLAMP 10497-05-000 WITHIN 200 OF OUTLET BOXES, USE SCREW 667-10-12B.
 3. ALL GROUND WIRE TO BE COVERED WITH TUBING 8041-02-000.
- 5 CUT LIGHT GREEN/RED WIRE FROM PARK BRAKE SWITCH AND RECONNECT TO CIRCUIT DY OF CHASSIS ASM AS SHOWN.
 4 CUT WIRE AND RECONNECT AS SHOWN.

FOR ELECTRICAL TORQUE SPECIFICATIONS SEE DWG NO. 128783-01-000

FOR ELECTRICAL CALLOUTS SEE DWG NO. 121339-01-000

- 9L1 HOME COMFORT PLUS PACKAGE
- 74J REARVIEW MONITOR SYSTEM
- 28X MIRRORS-EXTERIOR W/DEFROST
- 56F HEATER-AUXILIARY AUTOMOTIVE
- 265 CODES/STANDARDS-CSA/CMVSS
- 1B1 CODES/STANDARDS USA

FIRST USED	05 430V
TITLE	DO NOT SCALE DRAWING
WIRING INSTL-CHASSIS	
SHEET 2	PART NO 148948

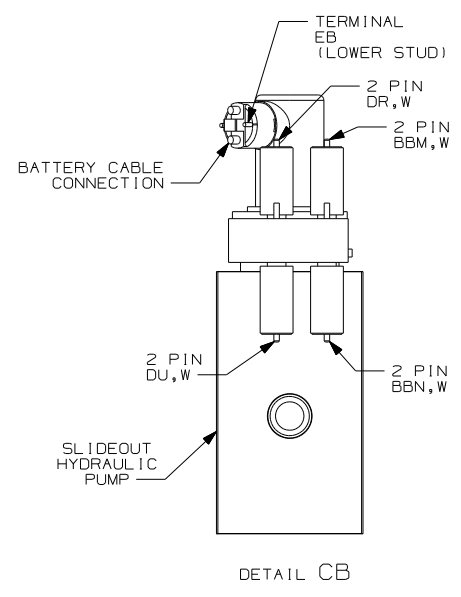

TO ELECTRIC STEP DOOR SWITCH

- BATTERY 063739-01-000 (2)
- TIEDOWN 65451-05-000 (2)
- BOLT 51387-06-000 (4)
- NUT D39-05-00B (4)
- BOOT 77479-01-000
- 77479-02-000

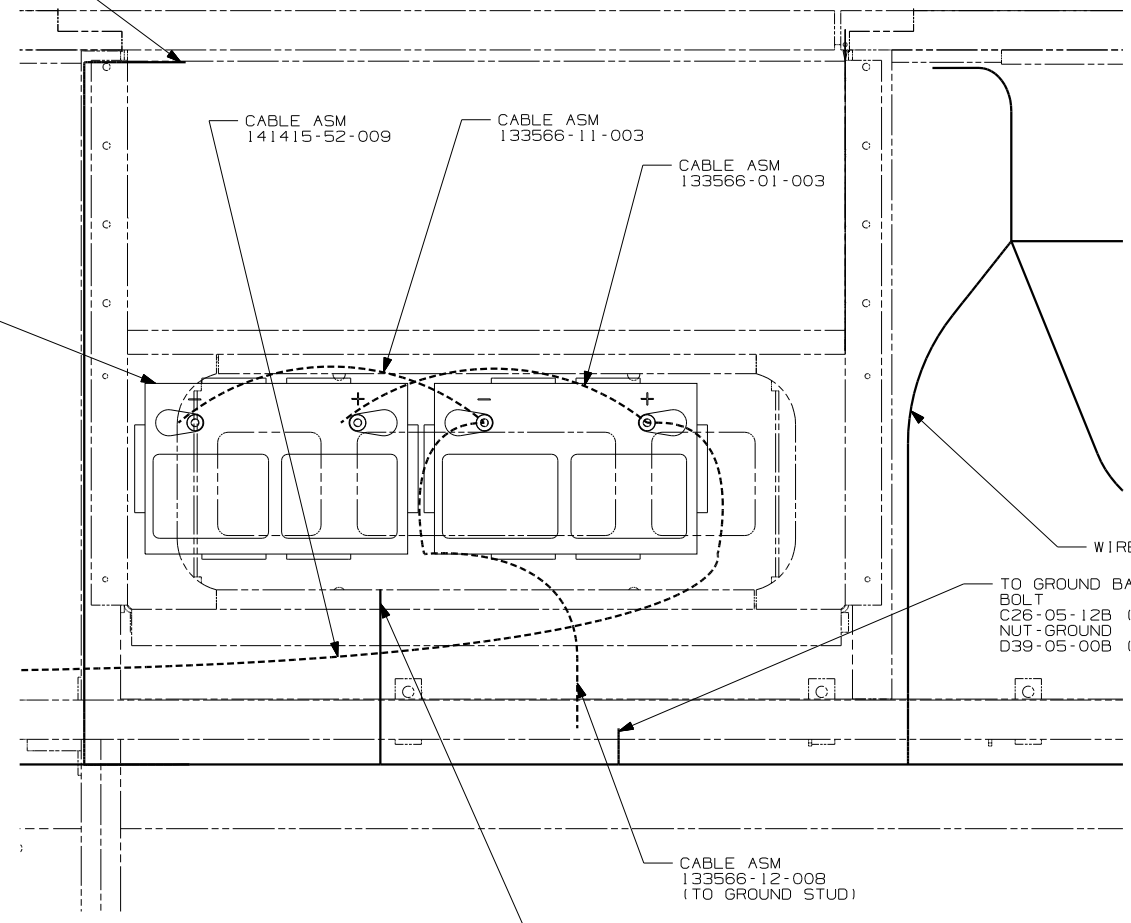

REMOVE A-PILLAR LOWER COVER TO ACCESS FORD CONNECTORS TO DOOR ASM.
CONNECT RED/ORG TO WL (2 PLACES)
CONNECT PK/BLK TO WM (2 PLACES)
FOR POWER DOOR LOCK ACTUATOR

WIRE ASM-CHASSIS (REF)

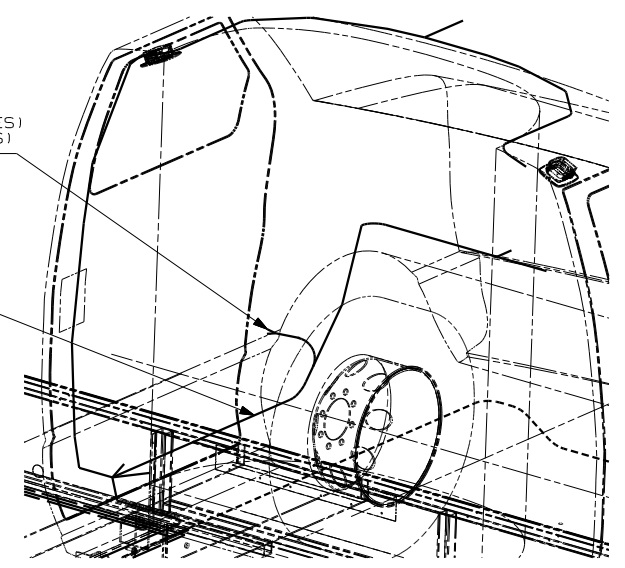

265 CODES/STANDARDS-CSA/CMVSS

1B1 CODES/STANDARDS USA

1B1 265

FIRST USED	05 430V
DO NOT SCALE DRAWING	
TITLE	WIRING INSTL-CHASSIS
SHEET 3	PART NO 148948

FOR ELECTRICAL TORQUE SPECIFICATIONS SEE DWG NO. 128783-01-000

FOR ELECTRICAL CALLOUTS SEE DWG NO. 121339-01-000