

- (1B1) CODES/STANDARDS-USA
- (265) CODES/STDS-CSA/CMVSS
- (49X) BED-QUEEN BACKWALL
- (438) DINETTE L-SHAPED
- (33R) DINETTE L-SHAPED (CSA)
- (16C) FORD CHASSIS 11,500 LB.GVWR
- (1CW) CHEVY CHASSIS 12,300 LB.GVWR
- (23T) HEATED HOLDING TANKS PACKAGE

9. VENT PIPE MUST PROJECT 51 MM MIN AND 64 MM MAX ABOVE ROOF FOR PROPER FIT AND FUNCTION.
8. SEE DRAWING 61607-01-000 FOR INSTL OF GROMMETS.
7. SEAL ALL AROUND SHOWER WITH SILICONE.
6. SECURE VENT TUBES TO FLOOR WITH CLAMP 62401-02-000 (3) AND SCREW G67-10-12B (3).
5. SECURE PIPES TO CABINET USING WIRE TIE 108046-02-000 AND SCREW G67-10-12B (8).
4. ALL EXTERIOR OPENINGS AROUND PIPE TO BE SEALED WITH 110744-01-000.
3. ALL PIPE AND FITTINGS TO BE ASSEMBLED WITH SOLVENT 4020-01-000.
2. SLOPE OF TRAP ARM MUST BE 6 PER 305.
1. SLOPE OF HORIZONTAL PIPING TO BE 6 PER 305 MIN.

NOTES:

<b>WINNEBAGO</b>		COPYRIGHT 2005 WINNEBAGO INDUSTRIES, INC.	
DFTR	ORIG. DATE	ALL DIMENSIONS ARE IN MILLIMETERS	
CHKR		FIRST USED	
P.E.		05 324V	
M.E.		UNSPECIFIED TOLERANCES ARE:	
DSNR		MATERIAL:	
		WHOLE DIM (X) :	3
		ONE-PLACE (X.X) :	
		TWO-PLACE (X.XX) :	
		ANGLE :	
		THIRD ANGLE PROJECTION	
DO NOT SCALE DRAWING			
TITLE: DRAINAGE SYSTEM INSTL			
SHEET 1 OF 3	PART NO	150300	
REF:145079 1 1/19/2005			

FOR  
DRAINAGE  
CALLOUTS  
SEE DWG NO.  
116229-01-000



8 7 6 5 4 3 2 1

8 7 6 5 4 3 2 1

D  
C  
B  
A

D  
C  
B  
A

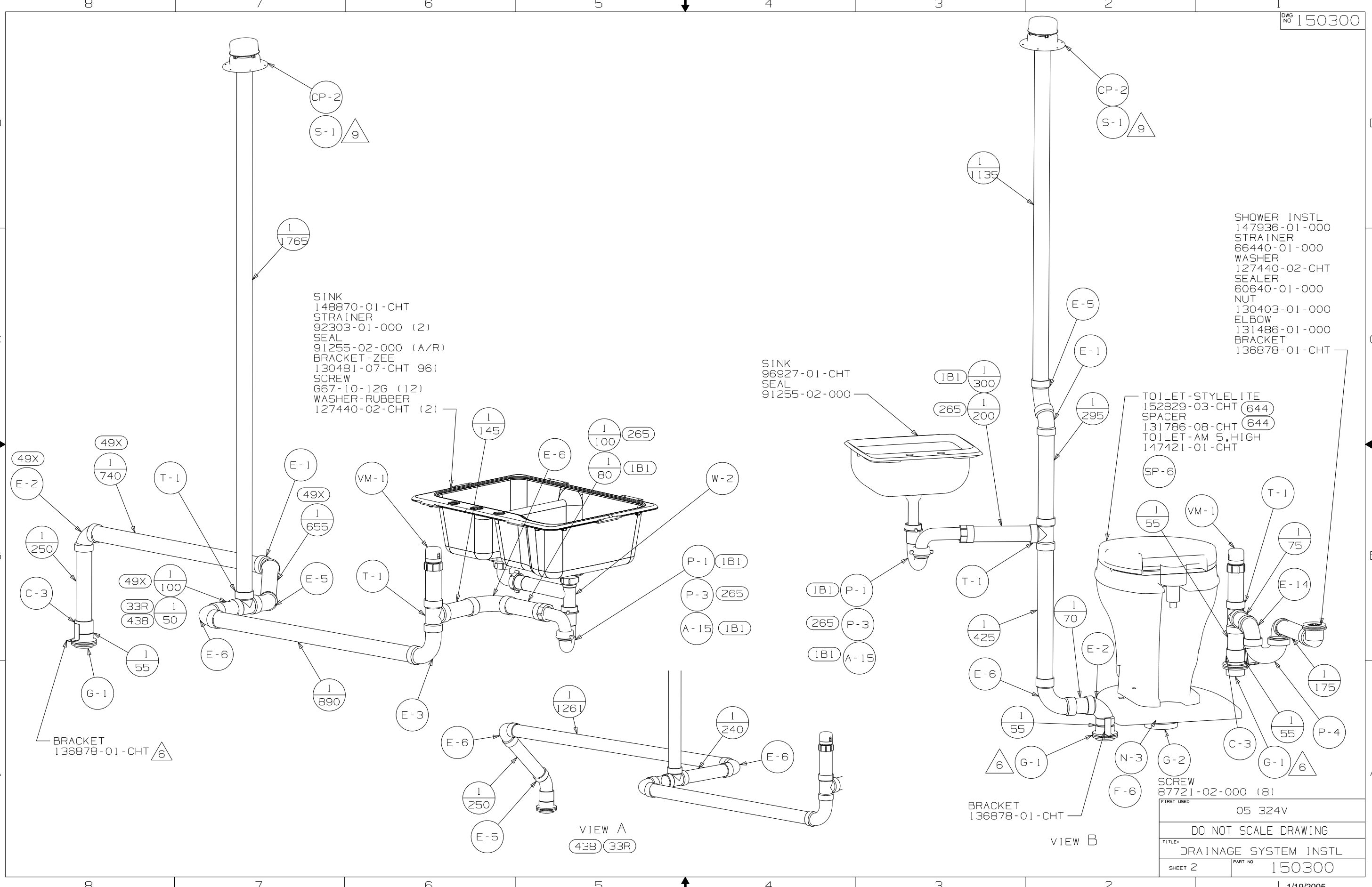

SINK  
 148870-01-CHT  
 STRAINER  
 92303-01-000 (2)  
 SEAL  
 91255-02-000 (A/R)  
 BRACKET-ZEE  
 130481-07-CHT 96)  
 SCREW  
 G67-10-12G (12)  
 WASHER-RUBBER  
 127440-02-CHT (2)

SHOWER INSTL  
 147936-01-000  
 STRAINER  
 66440-01-000  
 WASHER  
 127440-02-CHT  
 SEALER  
 60640-01-000  
 NUT  
 130403-01-000  
 ELBOW  
 131486-01-000  
 BRACKET  
 136878-01-CHT

TOILET-STYLE LITE  
 152829-03-CHT (644)  
 SPACER  
 131786-08-CHT (644)  
 TOILET-AM 5,HIGH  
 147421-01-CHT

SINK  
 96927-01-CHT  
 SEAL  
 91255-02-000

VIEW A  
 438 33R

VIEW B

FIRST USED	05 324V
DO NOT SCALE DRAWING	
TITLE: DRAINAGE SYSTEM INSTL	
SHEET 2	PART NO 150300

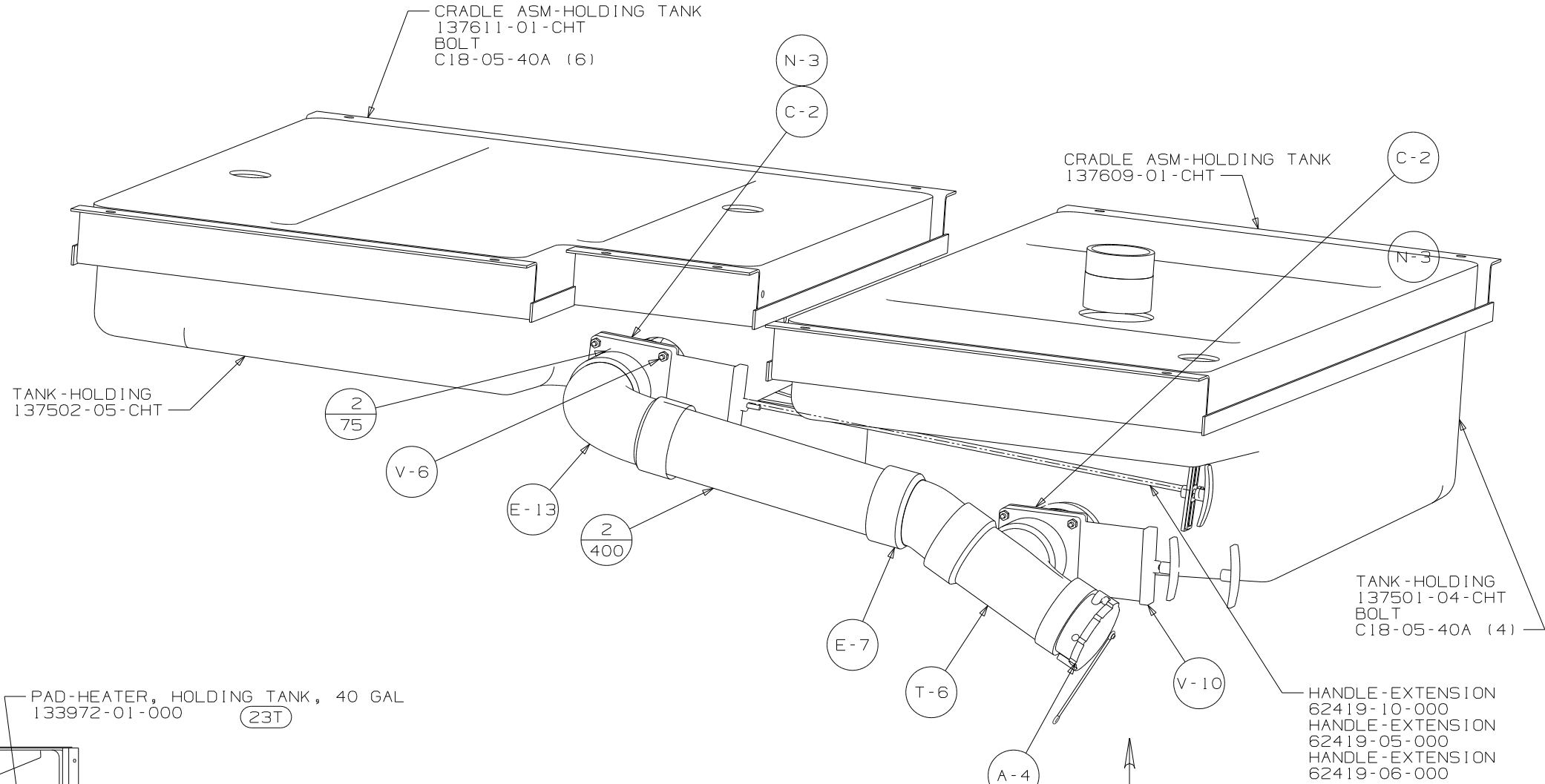

FIRST USED	05 324V
TITLE	DO NOT SCALE DRAWING
SHEET 3	PART NO 150300
DRAINAGE SYSTEM INSTL	
1 1/19/2005	

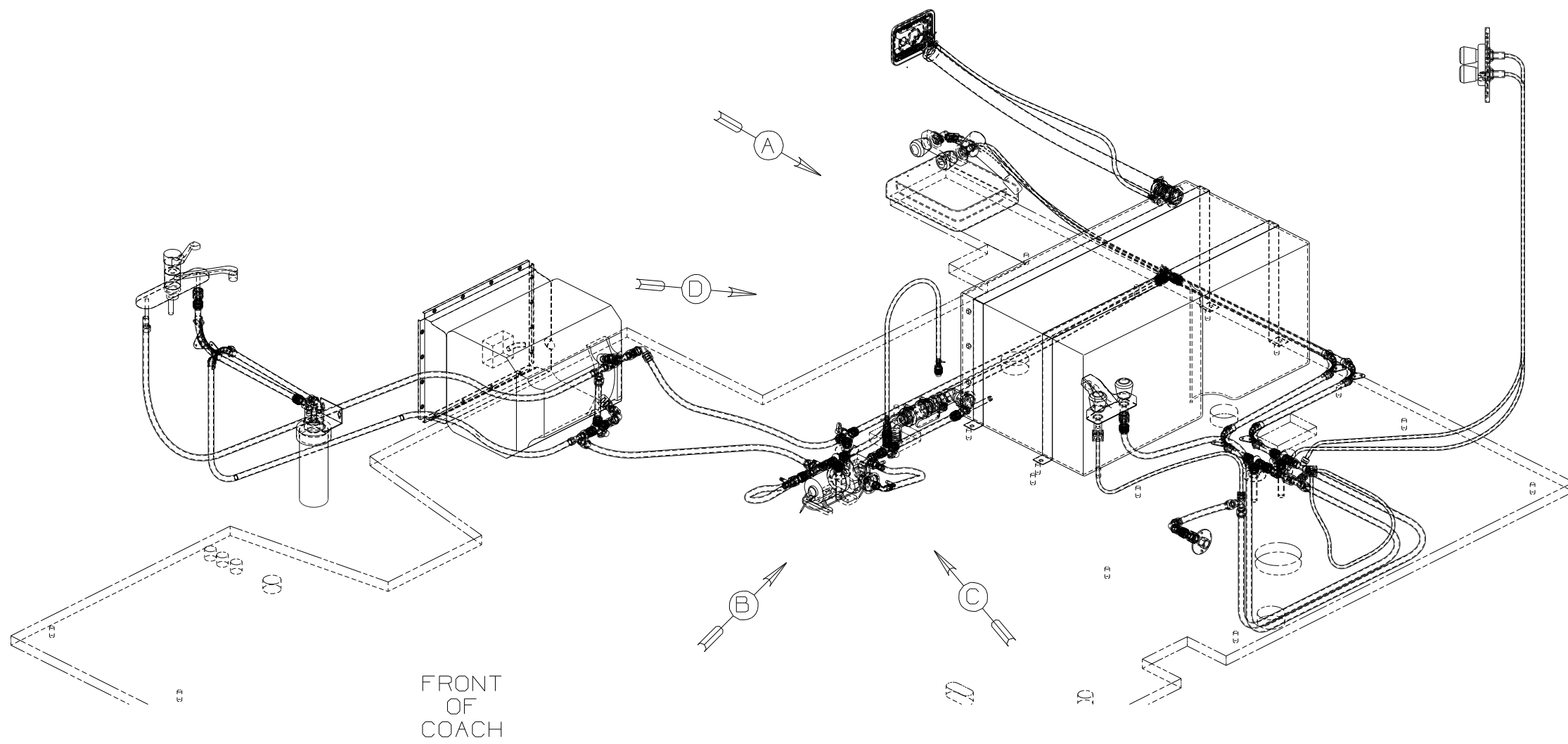

- (29B) WATER PURIFIER
- (501) WATER PURIFIER W/O
- (53E) WATER SYS WINTERIZATION PKG
- (64R) EXTERIOR WASH STATION
- (1J4) EXTERIOR SHWR-W/OUT
- (49X) BED-QUEEN-BACKWALL
- (43B) DINETTE L-SHAPED
- (33R) DINETTE L-SHAPED (CSA)
- (53F) WATER HEATER-6 GAL-ELEC IGN

- NOTES:
1. PLASTIC FITTINGS TO BE SEALED WITH SEALANT 84456-01-000.
  2. TUBING TO BE INSTALLED WITH SUFFICIENT SLOPE TO PROVIDE DRAINAGE TO NEAREST VALVE.
  3. ALL TUBING TO BE SECURED AT 1200 INTERVALS MAXIMUM WITH CLAMP 10495-01-000 OR CLIP 9151-01-000 AND SCREW G67-10-12B.
  4. ADD TEFLON TAPE 10405-02-000.
  5. ADD TEFLON TAPE 10405-03-000.
  6. ADD TEFLON TAPE 10405-01-000.
  7. ATTACH WASHER-PLASTIC 87080-11-CHT WITH TAPE-DOUBLE 123816-03-000 ON BOTTOM SIDE OF COMPARTMENT.
  8. ATTACH WASHER-PLASTIC 87080-13-CHT WITH TAPE-DOUBLE 123816-03-000 ON BOTTOM SIDE OF FLOOR.
  9. TAPE FITTING TO TUBE BEFORE CABINET SET TO PREVENT FITTING FROM MOVING.
  10. LABEL THE HOT AND COLD SUPPLY TUBES.

<b>WINNEBAGO</b>		COPYRIGHT 2005 WINNEBAGO INDUSTRIES, INC.	
DFTR	ORIG. DATE	ALL DIMENSIONS ARE IN MILLIMETERS	
CHKR		FIRST USED	
P.E.		05 324V	
M.E.		UNSPECIFIED TOLERANCES ARE:	
DSNR		MATERIAL:	
		WHOLE DIM (X)	: 3
		ONE-PLACE (X.X)	:
		TWO-PLACE (X.XX)	:
		ANGLE	:
THIRD ANGLE PROJECTION		DO NOT SCALE DRAWING	
TITLE: WATER SYSTEM INSTL			
SHEET 1 OF 4		PART NO 150305	

(X-X)  
FOR  
WATER  
CALLOUTS  
SEE DWG NO  
116230-01-000

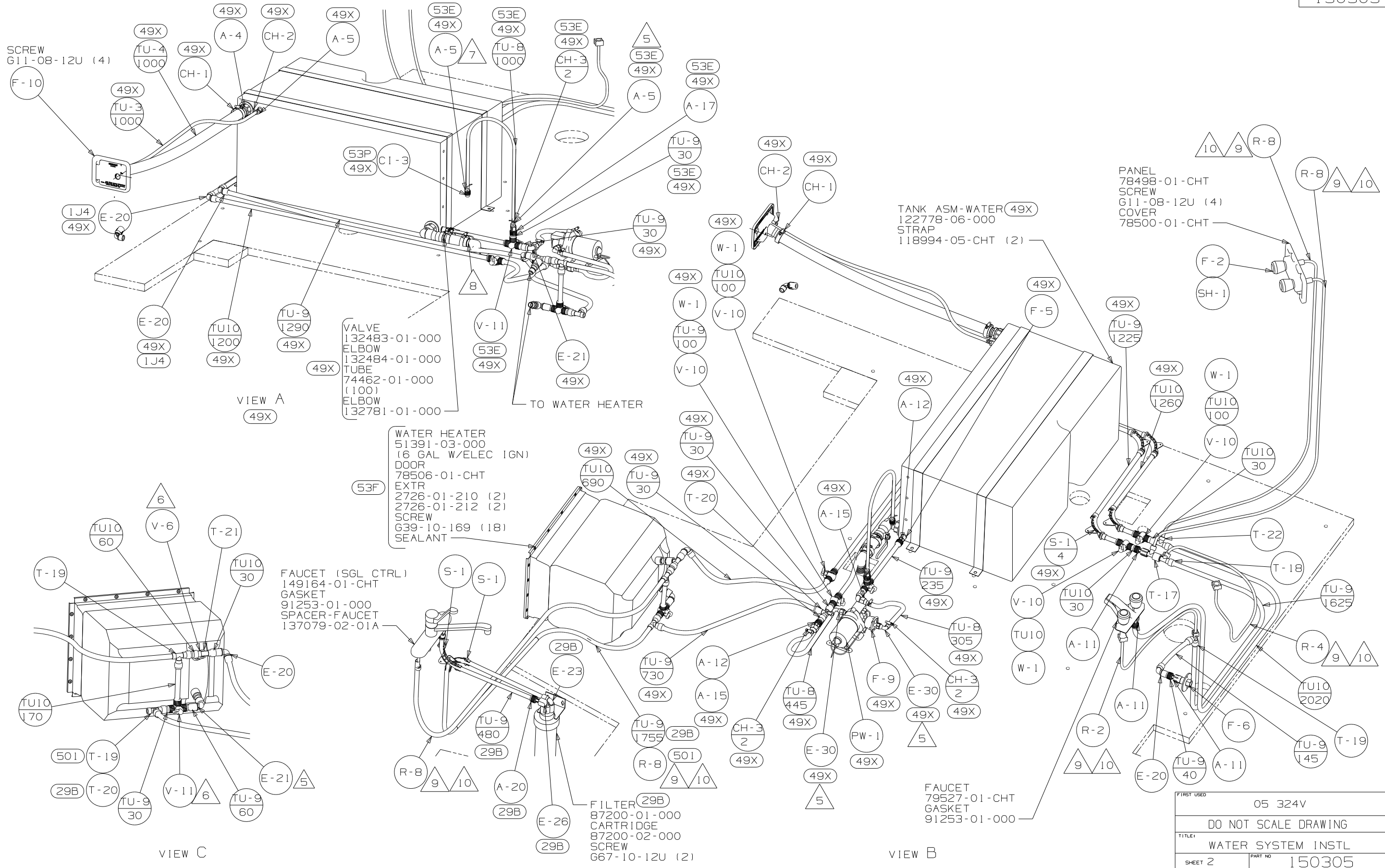

SCREW  
G11-08-12U (4)

VALVE  
132483-01-000  
ELBOW  
132484-01-000  
TUBE  
74462-01-000  
(100)  
ELBOW  
132781-01-000

WATER HEATER  
51391-03-000  
(6 GAL W/ELEC IGN)  
DOOR  
78506-01-CHT  
EXTR  
2726-01-210 (2)  
2726-01-212 (2)  
SCREW  
G39-10-169 (18)  
SEALANT

FAUCET (SGL CTRL)  
149164-01-CHT  
GASKET  
91253-01-000  
SPACER-FAUCET  
137079-02-01A

FILTER  
87200-01-000  
CARTRIDGE  
87200-02-000  
SCREW  
G67-10-12U (2)

TANK ASM-WATER  
122778-06-000  
STRAP  
118994-05-CHT (2)

PANEL  
78498-01-CHT  
SCREW  
G11-08-12U (4)  
COVER  
78500-01-CHT

FAUCET  
79527-01-CHT  
GASKET  
91253-01-000

FIRST USED	05 324V
DO NOT SCALE DRAWING	
TITLE	WATER SYSTEM INSTL
SHEET 2	PART NO 150305

TANK ASM  
127281-04-000  
STRAP  
118994-06-CHT (2)

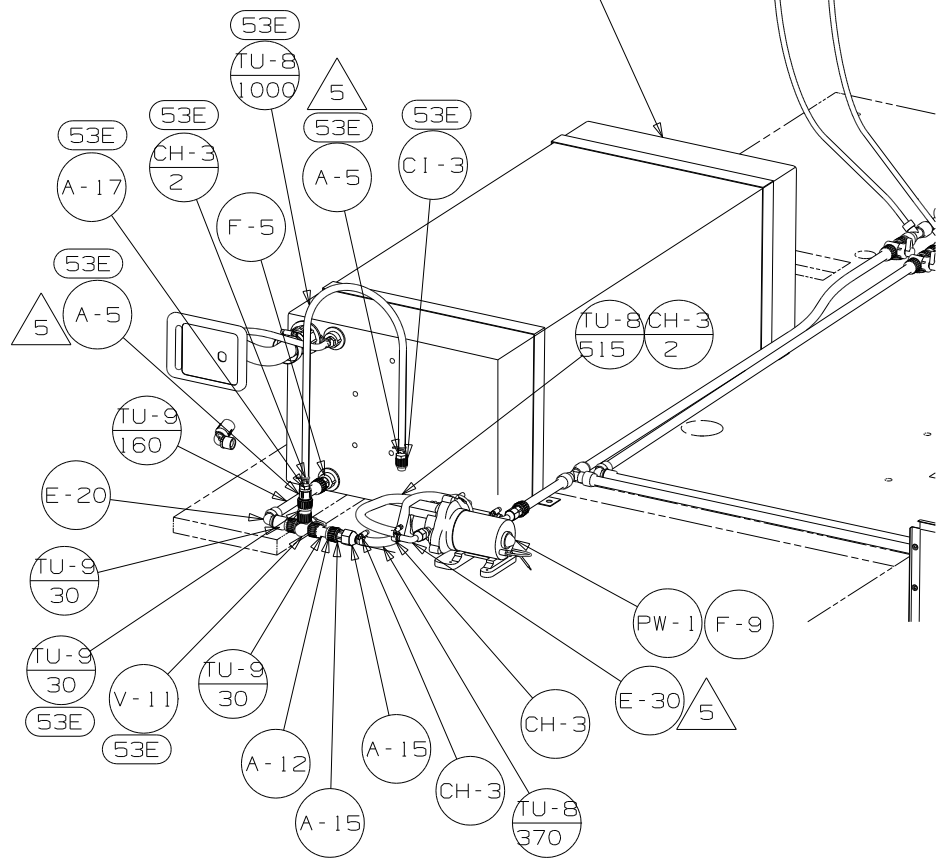

VIEW A  
438 33R

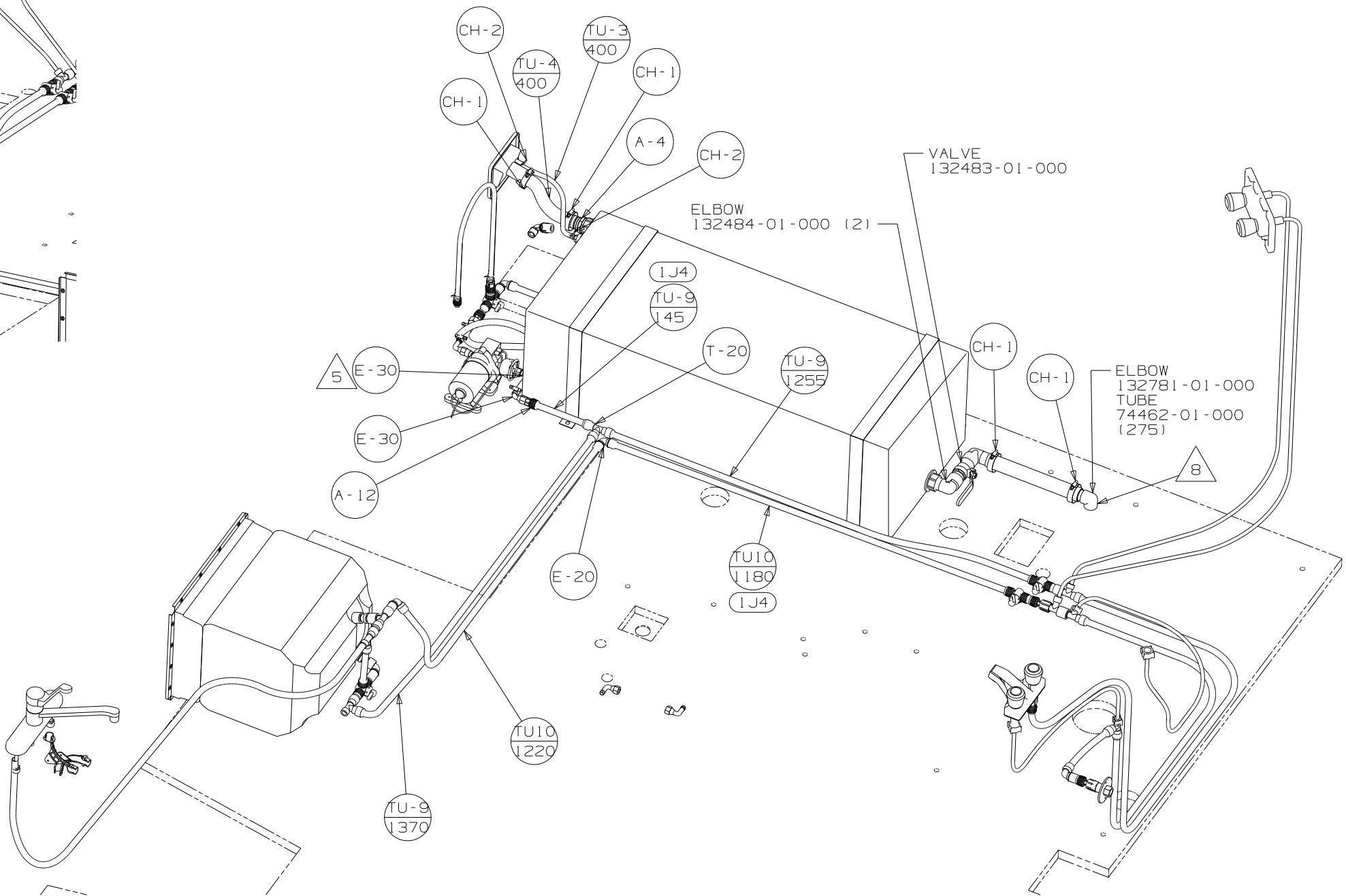

VIEW B  
438 33R

FIRST USED	05 324V
TITLE	DO NOT SCALE DRAWING
	WATER SYSTEM INSTL
SHEET 3	PART NO 150305

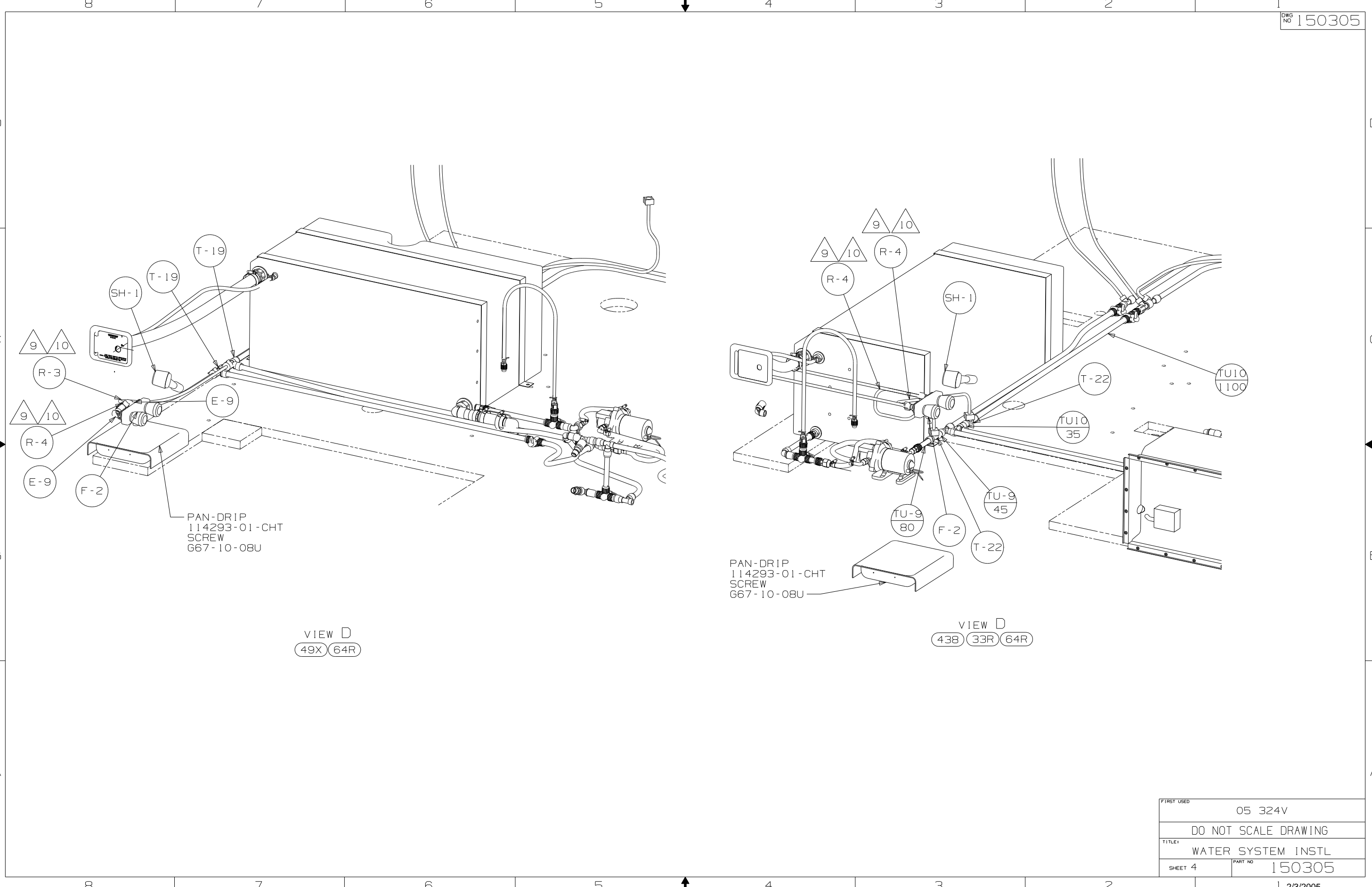

PAN-DRIP  
114293-01-CHT  
SCREW  
667-10-08U

VIEW D  
49X 64R

PAN-DRIP  
114293-01-CHT  
SCREW  
667-10-08U

VIEW D  
438 33R 64R

FIRST USED	05 324V
TITLE	DO NOT SCALE DRAWING
SHEET 4	PART NO 150305