



DANGER

Danger of electrical shock, burns or death. Always remove all power sources before attempting any repair, service or diagnostic work. Power can be present from shore power, generator, inverter or battery. All power sources must be disabled and secured before performing any service.



CAUTION

If you lack the skills, tools or equipment to perform diagnostic or repair work leave such work to an authorized Winnebago Industries dealer or other qualified shop.

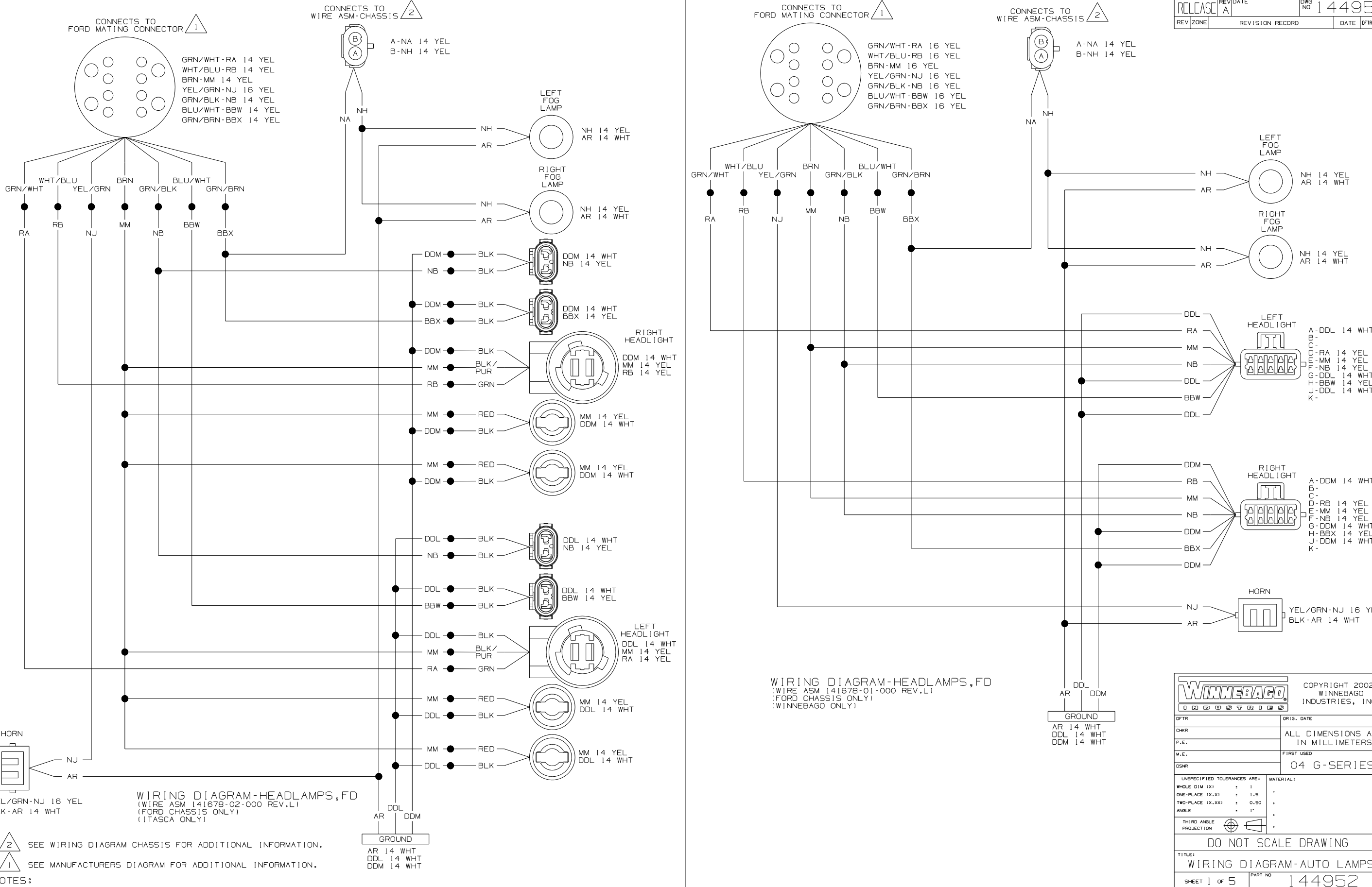

NOTES:

2 SEE WIRING DIAGRAM CHASSIS FOR ADDITIONAL INFORMATION.

1 SEE MANUFACTURERS DIAGRAM FOR ADDITIONAL INFORMATION.

WINNEBAGO COPYRIGHT 2002 WINNEBAGO INDUSTRIES, INC.

DFTR	ORIG. DATE
CHKR	ALL DIMENSIONS ARE IN MILLIMETERS
P.E.	FIRST USED
M.E.	04 G-SERIES
DSNR	

UNSPECIFIED TOLERANCES ARE:

WHOLE DIM (X)	: 1
ONE-PLACE (X.X)	: 1.5
TWO-PLACE (X.XX)	: 0.50
ANGLE	: 1°

THIRD ANGLE PROJECTION

DO NOT SCALE DRAWING

TITLE: **WIRING DIAGRAM-AUTO LAMPS**

SHEET 1 of 5 PART NO 144952

REF: 141450 1 05/21/03

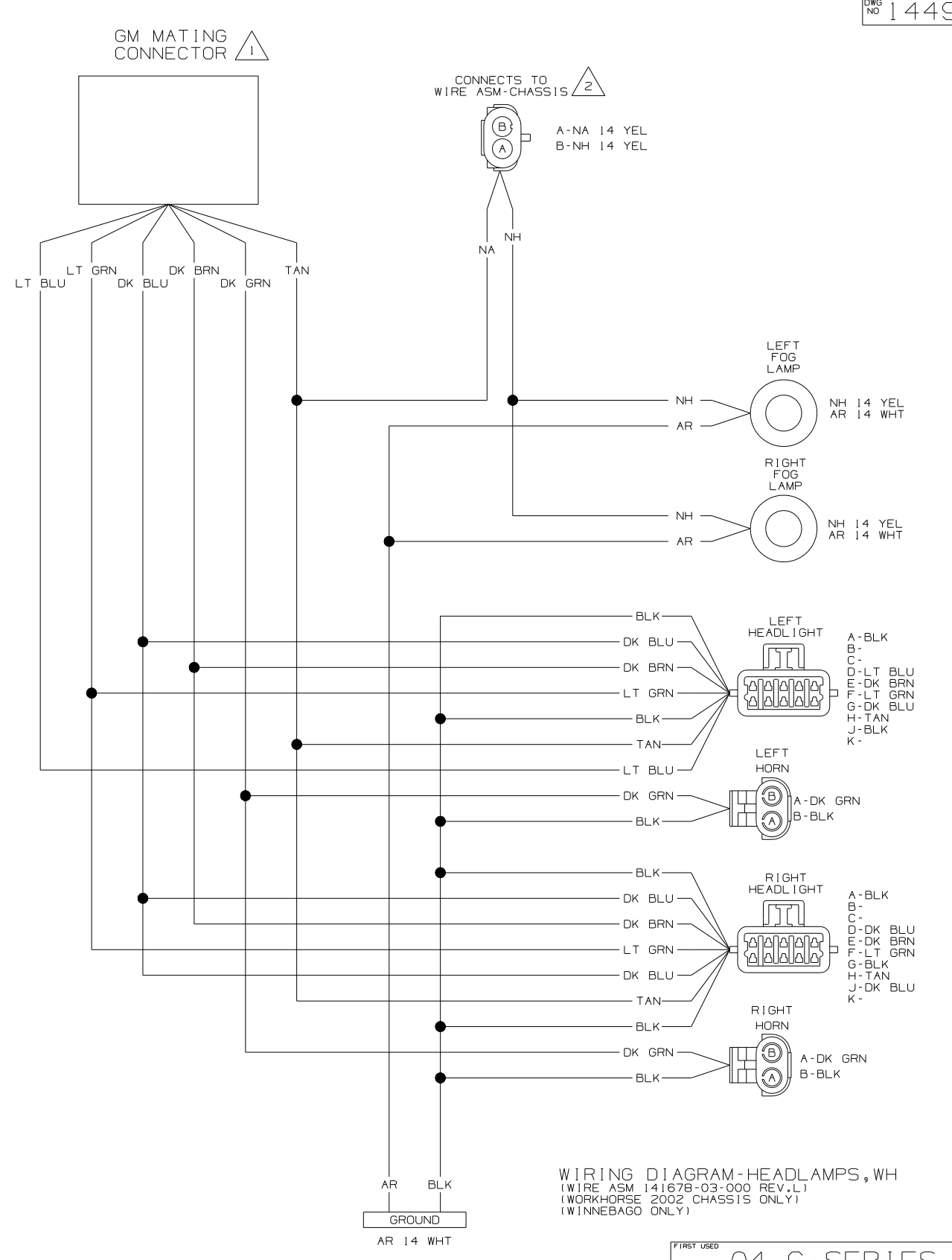
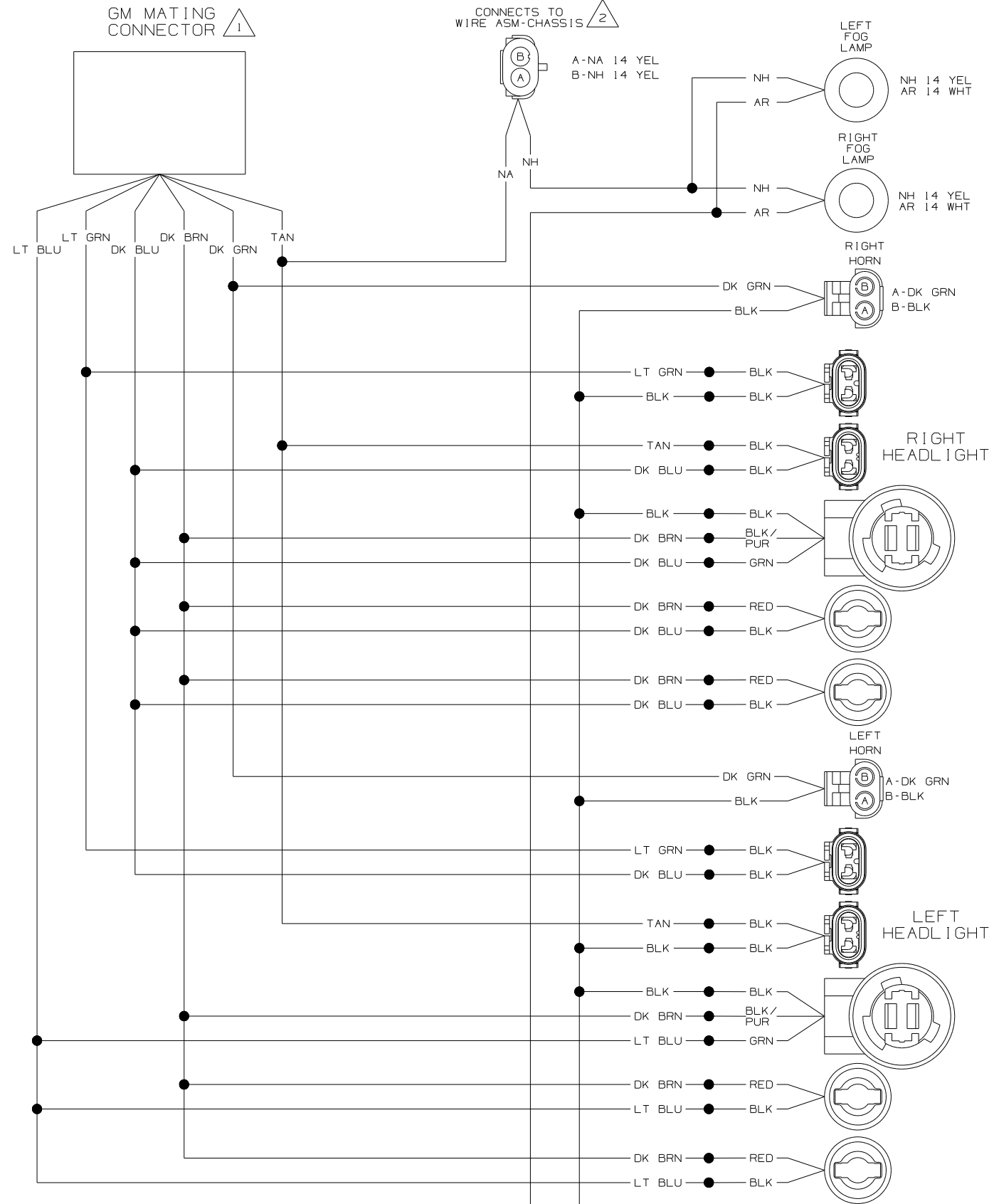

NOTES:
 2 SEE WIRING DIAGRAM CHASSIS FOR ADDITIONAL INFORMATION.
 1 SEE MANUFACTURERS DIAGRAM FOR ADDITIONAL INFORMATION.

WIRING DIAGRAM-HEADLAMPS, WH
 (WIRE ASM 141678-04-000 REV.L1)
 (WORKHORSE 2002 CHASSIS ONLY)
 (ITASCA ONLY)

WIRING DIAGRAM-HEADLAMPS, WH
 (WIRE ASM 141678-03-000 REV.L1)
 (WORKHORSE 2002 CHASSIS ONLY)
 (WINNEBAGO ONLY)

FIRST USED	04 G-SERIES
TITLE	DO NOT SCALE DRAWING
WIRING DIAGRAM-AUTO LAMPS	
SHEET 2	PART NO 144952

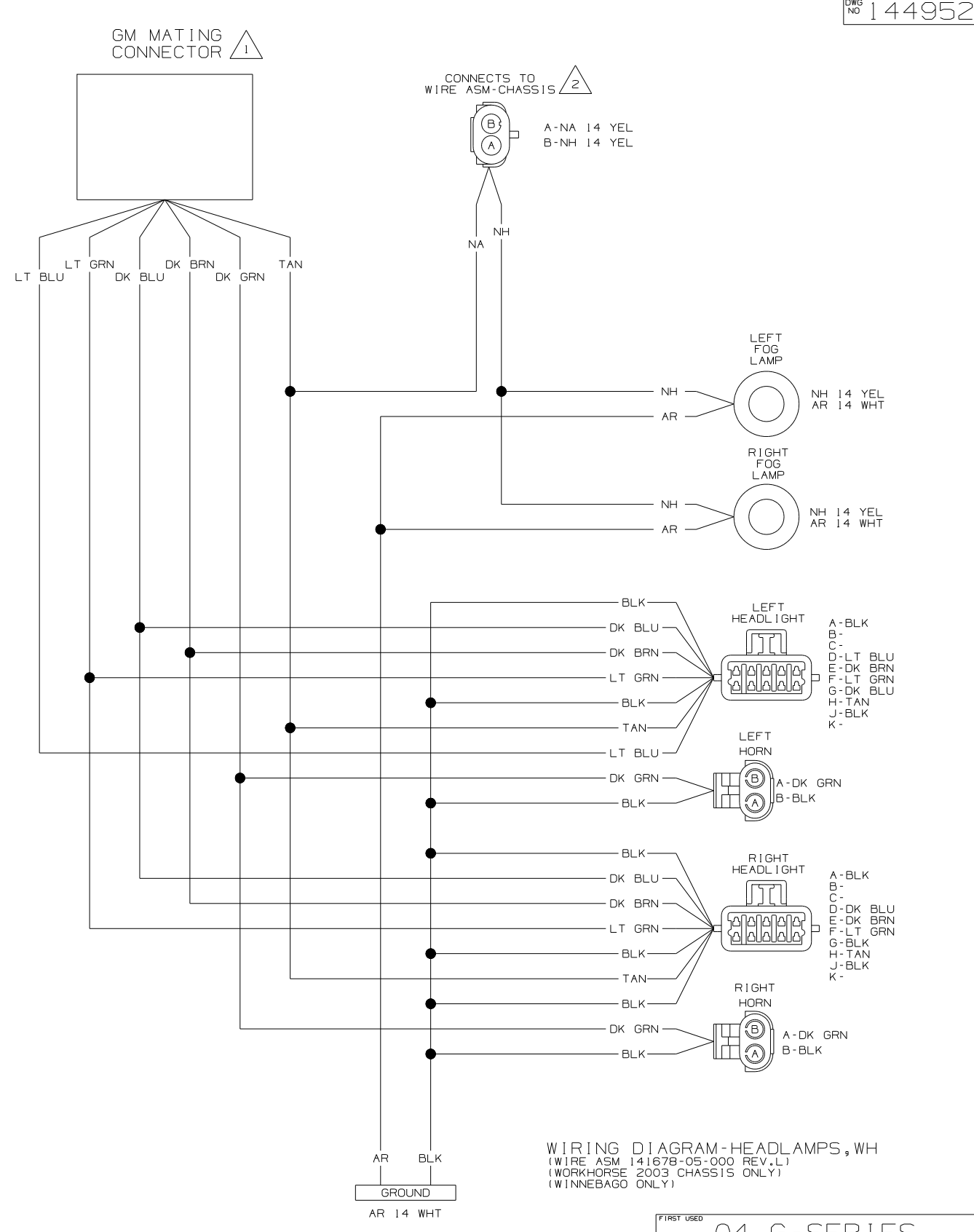
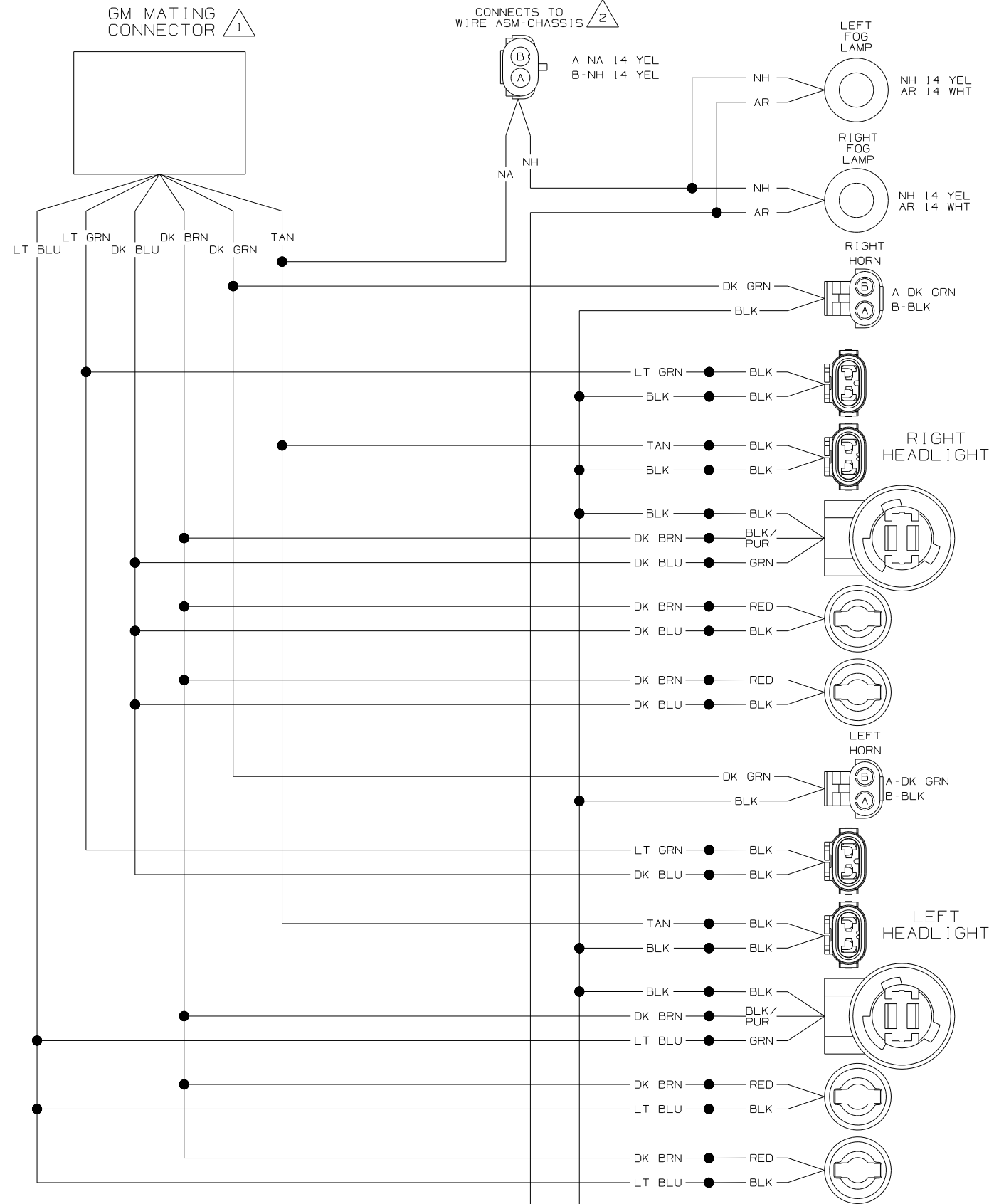

NOTES:
 2 SEE WIRING DIAGRAM CHASSIS FOR ADDITIONAL INFORMATION.
 1 SEE MANUFACTURERS DIAGRAM FOR ADDITIONAL INFORMATION.

WIRING DIAGRAM-HEADLAMPS, WH
 (WIRE ASM 141678-06-000 REV.L1)
 (WORKHORSE 2003 CHASSIS ONLY)
 (ITASCA ONLY)

WIRING DIAGRAM-HEADLAMPS, WH
 (WIRE ASM 141678-05-000 REV.L1)
 (WORKHORSE 2003 CHASSIS ONLY)
 (WINNEBAGO ONLY)

FIRST USED	04 G-SERIES
TITLE	DO NOT SCALE DRAWING
WIRING DIAGRAM-AUTO LAMPS	
SHEET 3	PART NO 144952

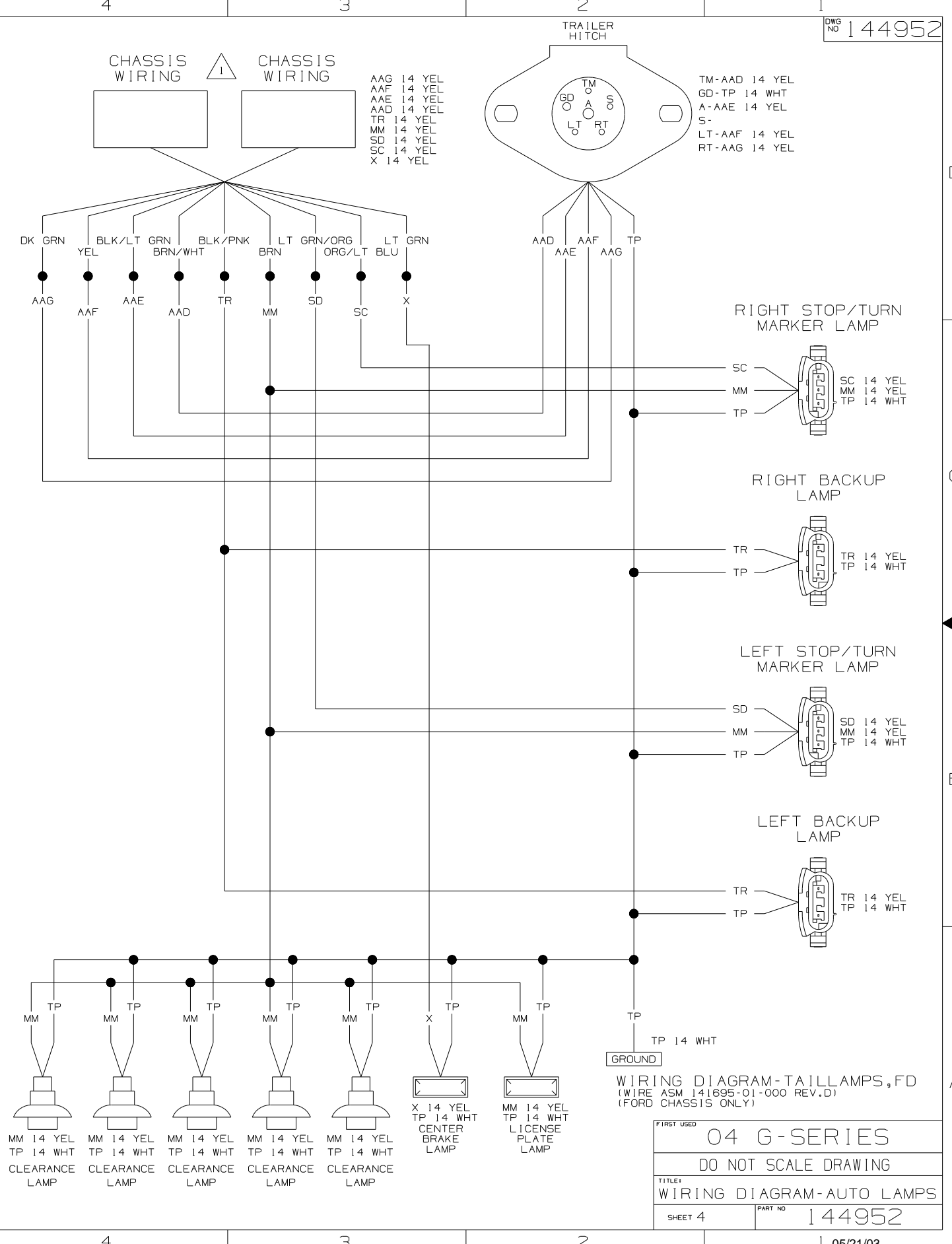
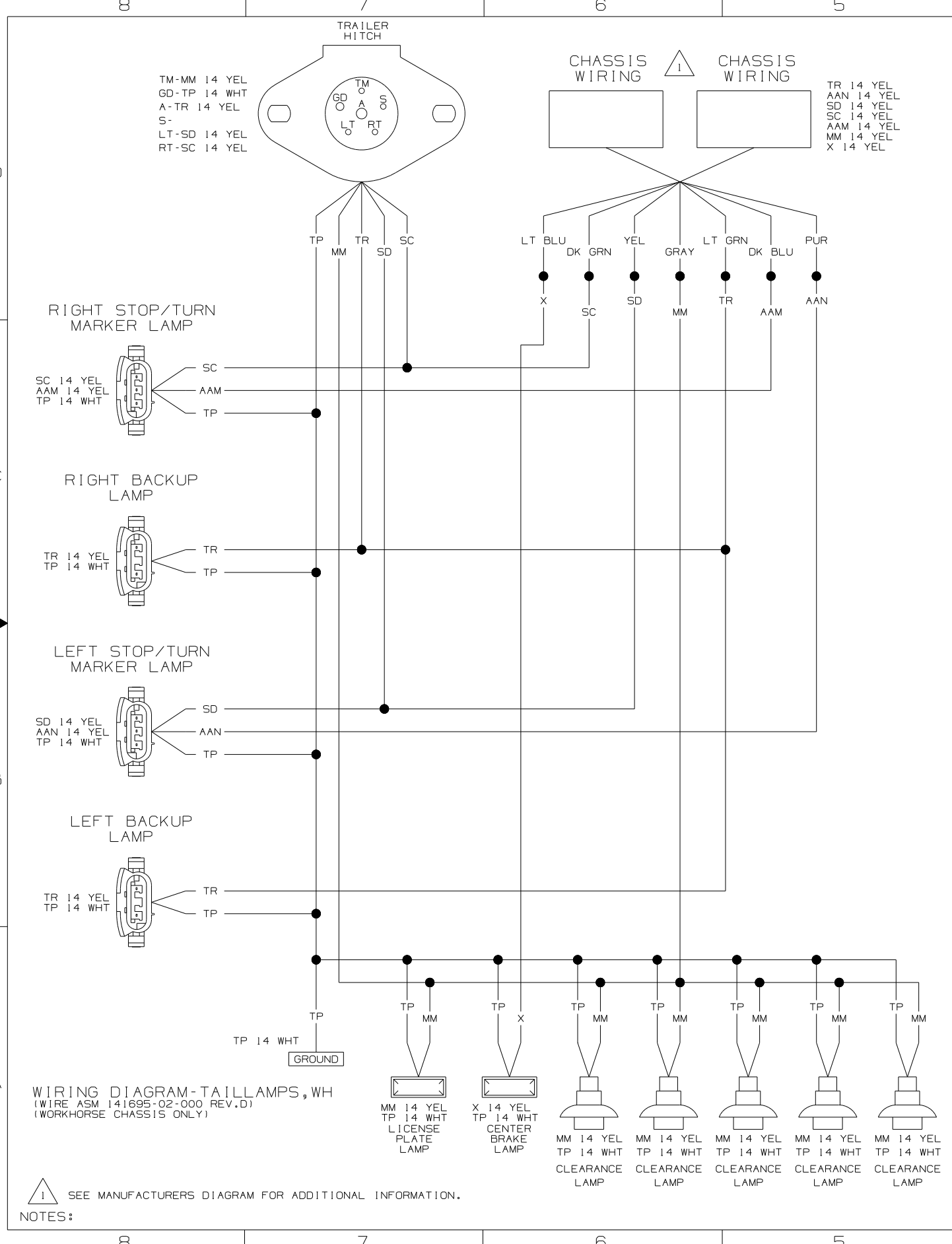

WIRING DIAGRAM-TAILLAMPS, WH (WIRE ASM 141695-02-000 REV.D) (WORKHORSE CHASSIS ONLY)

WIRING DIAGRAM-TAILLAMPS, FD (WIRE ASM 141695-01-000 REV.D) (FORD CHASSIS ONLY)

NOTES: 1 SEE MANUFACTURERS DIAGRAM FOR ADDITIONAL INFORMATION.

FIRST USED	
04 G-SERIES	
DO NOT SCALE DRAWING	
TITLE: WIRING DIAGRAM-AUTO LAMPS	
SHEET 4	PART NO 144952

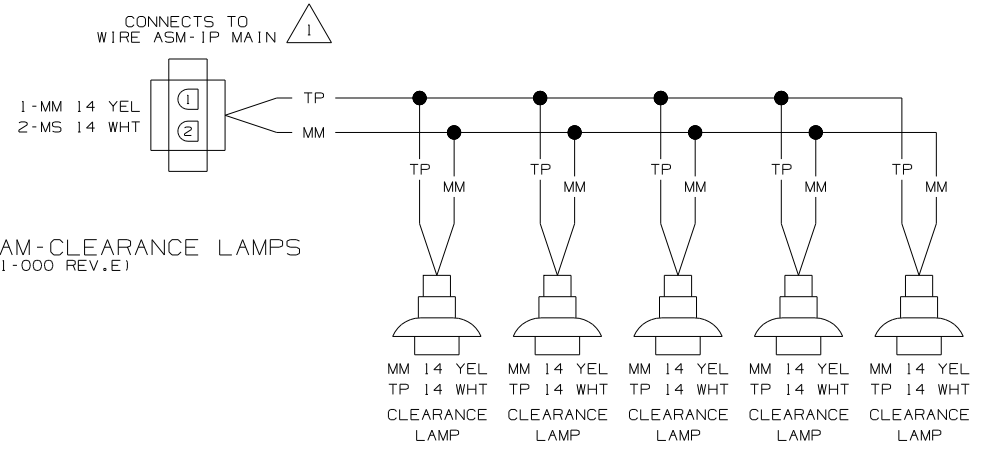

WIRING DIAGRAM-CLEARANCE LAMPS
(WIRE ASM 126486-01-000 REV.E)

NOTES:  SEE WIRING DIAGRAM-AUTO FOR ADDITIONAL INFORMATION.

FIRST USED	04 G-SERIES
TITLE	DO NOT SCALE DRAWING
TITLE	WIRING DIAGRAM-AUTO LAMPS
SHEET 5	PART NO 144952