



DANGER

Danger of electrical shock, burns or death. Always remove all power sources before attempting any repair, service or diagnostic work. Power can be present from shore power, generator, inverter or battery. All power sources must be disabled and secured before performing any service.



CAUTION

If you lack the skills, tools or equipment to perform diagnostic or repair work leave such work to an authorized Winnebago Industries dealer or other qualified shop.

DRAWING NO.	FEATURE
144950-01	(WIN)
144950-02	(ITA)

RELEASE	REV DATE	DWG NO
A		144950
REV ZONE	REVISION RECORD	DATE DFR-016

D

C

B

A

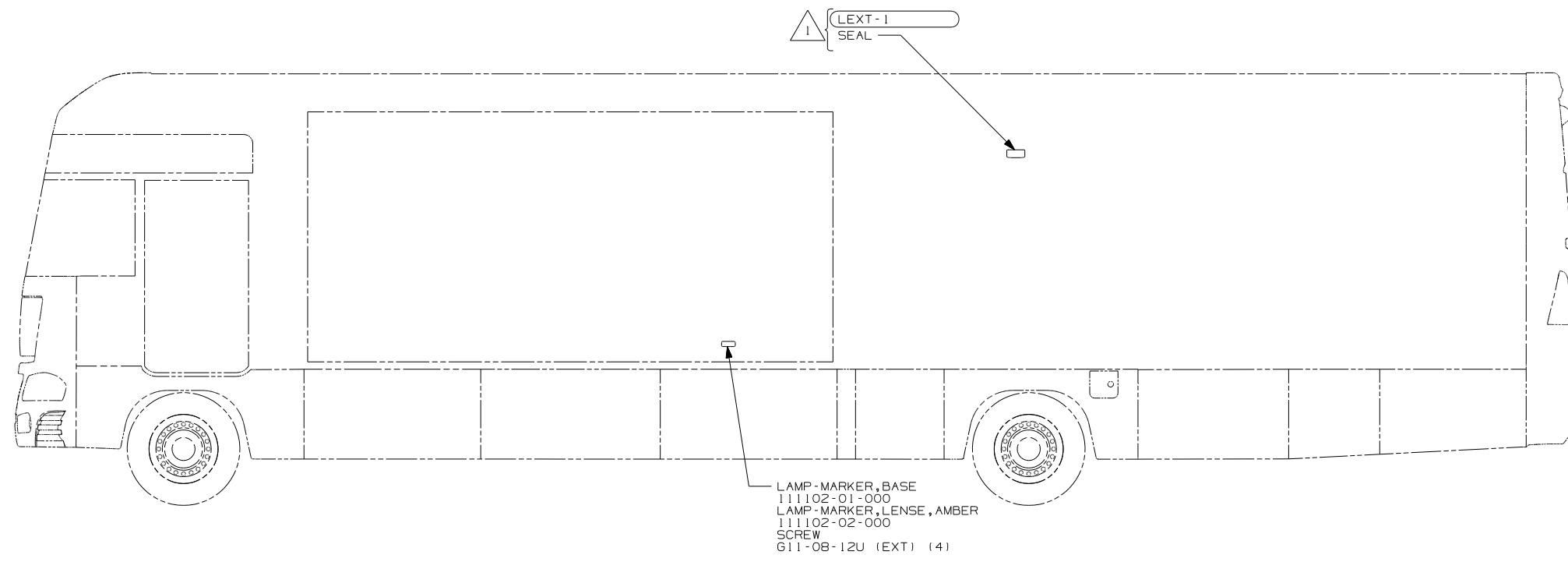
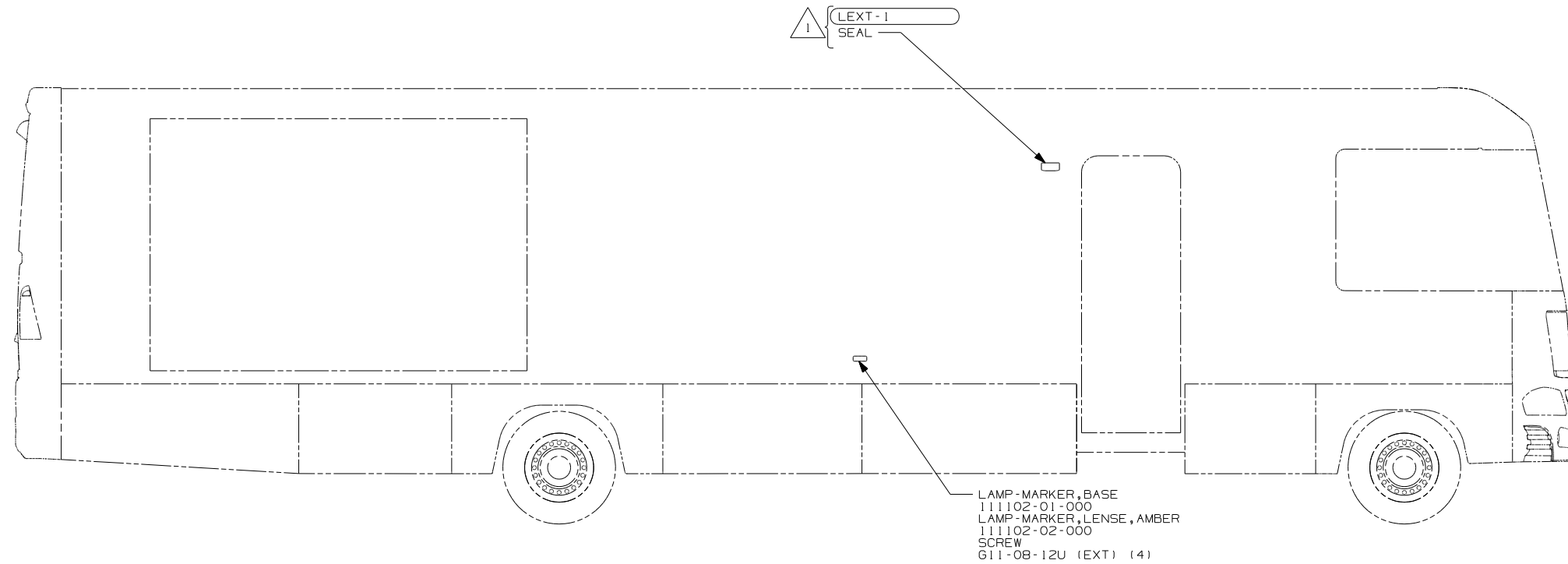

- (WIN) WINNEBAGO ONLY
- (ITA) ITASCA ONLY
- (265) CODES/STANDARDS - CSA/CMVSS
- (1B1) CODES/STANDARDS - USA

(1B1) (265)



DFTR	ORIG. DATE
CHKR	ALL DIMENSIONS ARE IN MILLIMETERS
P.E.	
M.E.	FIRST USED
DSNR	04 G-SERIES
UNSPECIFIED TOLERANCES ARE:	MATERIAL:
HOLE DIM (X)	: 1
ONE-PLACE (X.X)	: 1.5
TWO-PLACE (X.XX)	: 0.50
ANGLE	: 1°
THIRD ANGLE PROJECTION	

FOR ELECTRICAL TORQUE SPECIFICATIONS SEE DWG NO. 128783-01-000

(X-X) FOR ELECTRICAL CALLOUTS SEE DWG NO. 121339-01-000

NOTES:
1 NOT USED ON SHELLS.

DO NOT SCALE DRAWING

TITLE: WIRING INSTL-EXTERIOR LAMPS

SHEET 1 OF 3 PART NO 144950

8

7

6

5

4

3

2

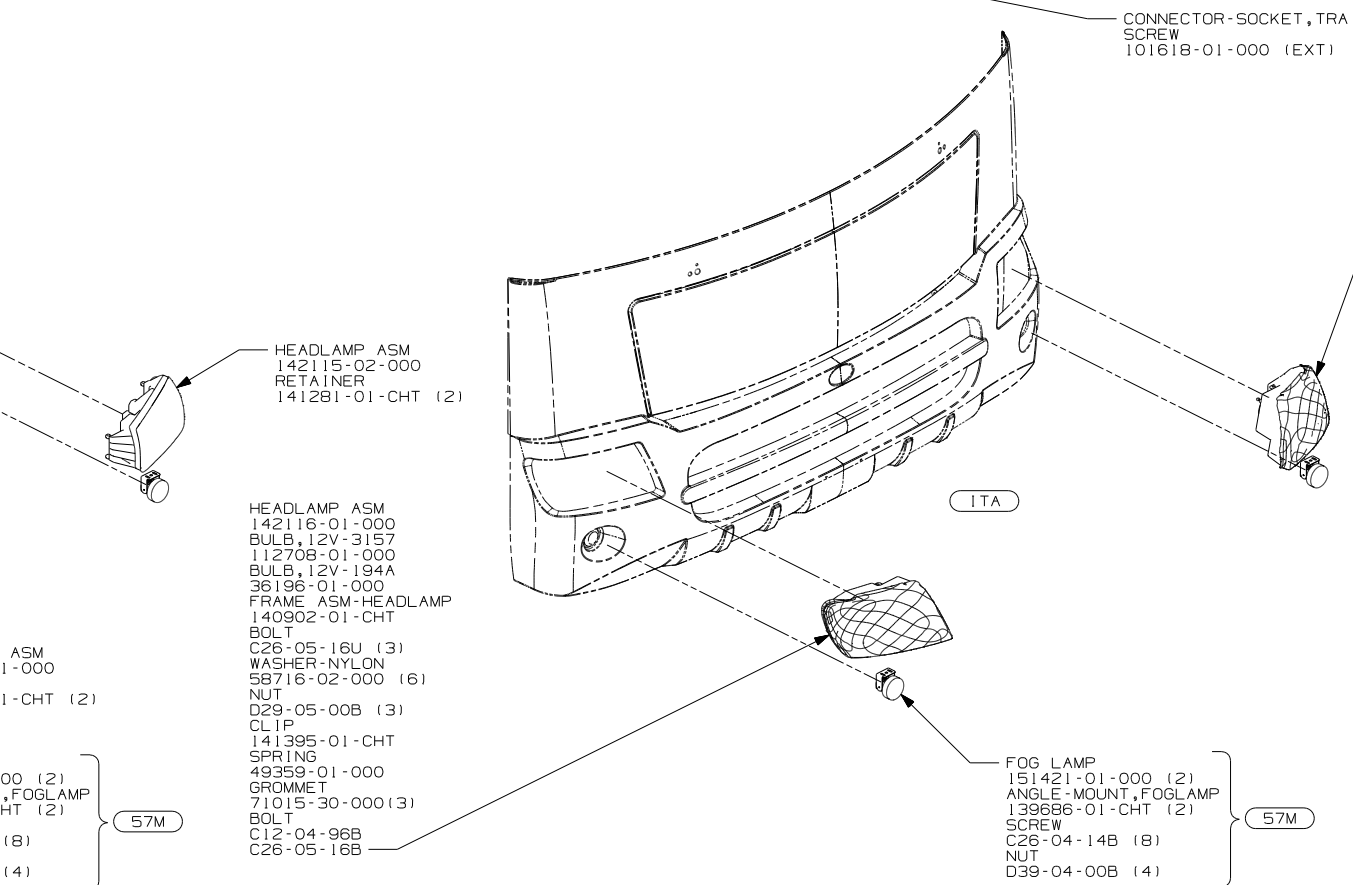
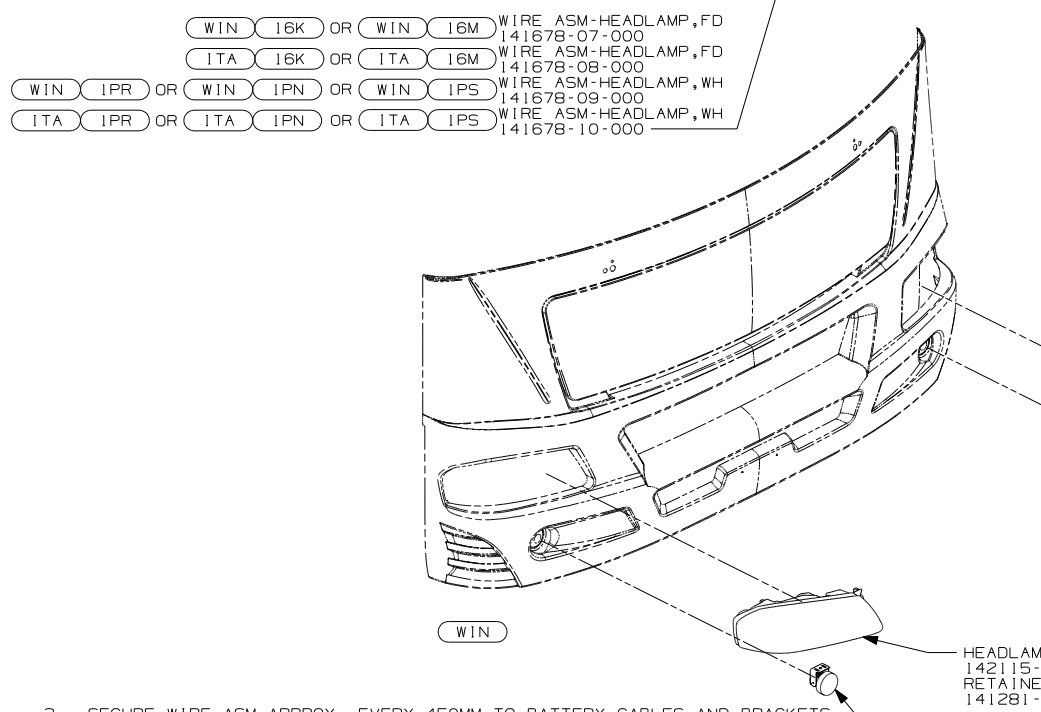
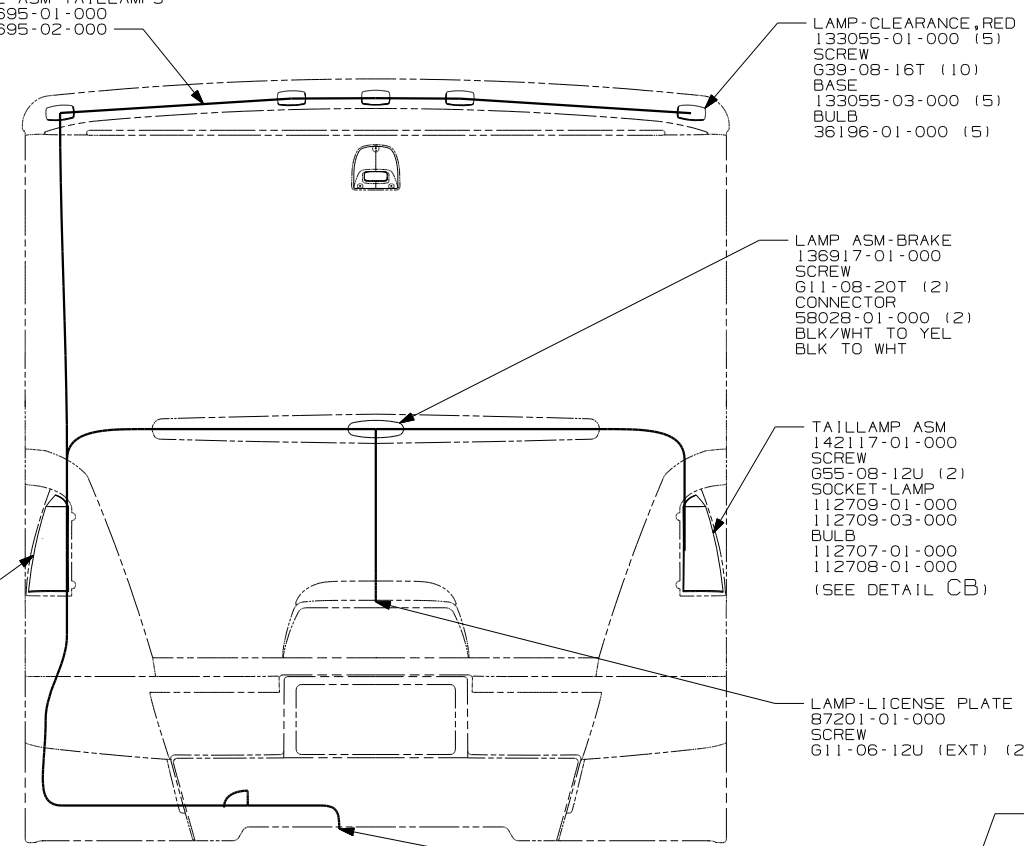
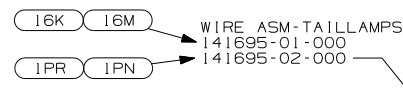
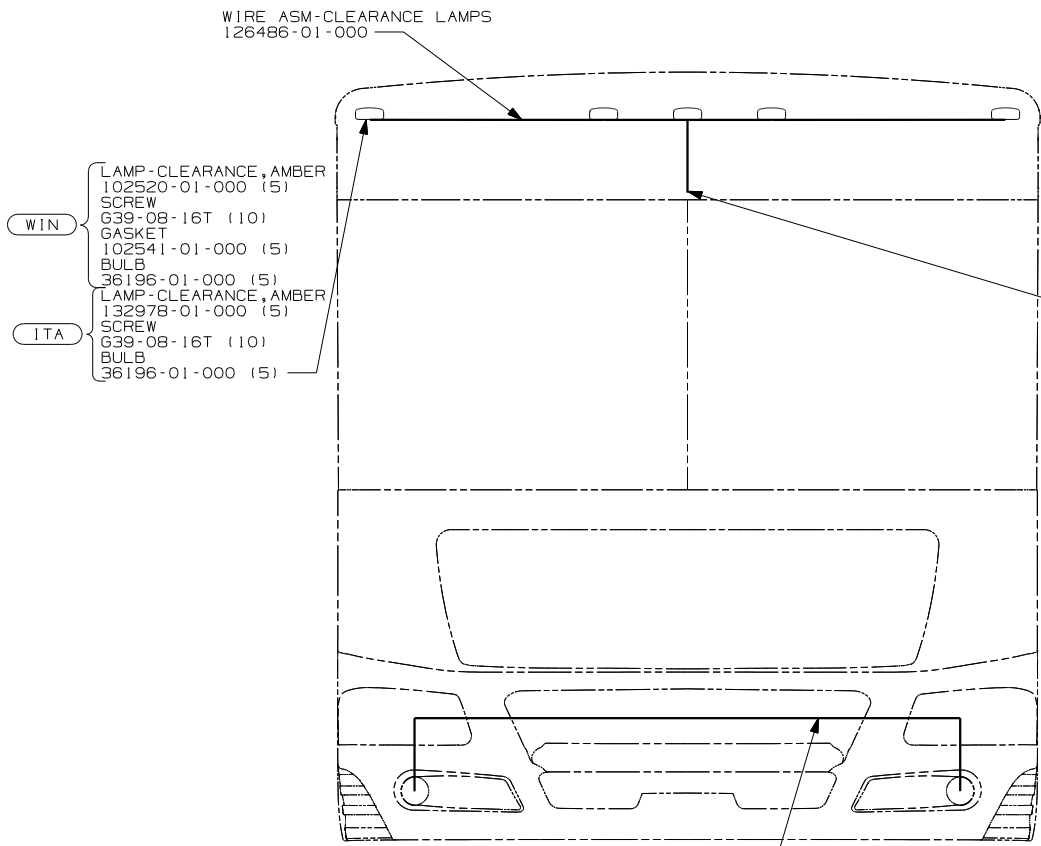

- WIN WINNEBAGO ONLY
- ITA ITASCA ONLY
- 57M FOG LAMPS
- 265 CODES/STANDARDS - CSA/CMVSS
- 1PS WORKHORSE 22,000#-22.5 TIRE
- 1PR WORKHORSE CHASSIS - 22,000# GVWR
- 1PN WORKHORSE CHASSIS - 20,700# GVWR
- 1B1 CODES/STANDARDS - USA
- 16M FORD CHASSIS - 20,500# GVWR
- 16K FORD CHASSIS - 22,000# GVWR

3. SECURE WIRE ASM APPROX. EVERY 450MM TO BATTERY CABLES AND BRACKETS. USE TIE-WIRE 8343-01-000 OR 93147-01-000 AS APPROPRIATE.
2. CLEAN PAINT OFF METAL (BOLT) BEFORE CONNECTING GROUND TO INSURE CONTACT. ALSO MOUNT CHASSIS SUPPLIED HORN TO GROUND BOLT.
1. GATHER ALL EXCESS WIRE AFTER MAKING ALL CONNECTIONS AND BUNDLE AND SECURE WITH TIE-WIRE 8343-01-000 OR 93147-01-000.

FIRST USED	
04 G-SERIES	
DO NOT SCALE DRAWING	
TITLE: WIRING INSTL-EXTERIOR LAMPS	
SHEET 2	PART NO 144950

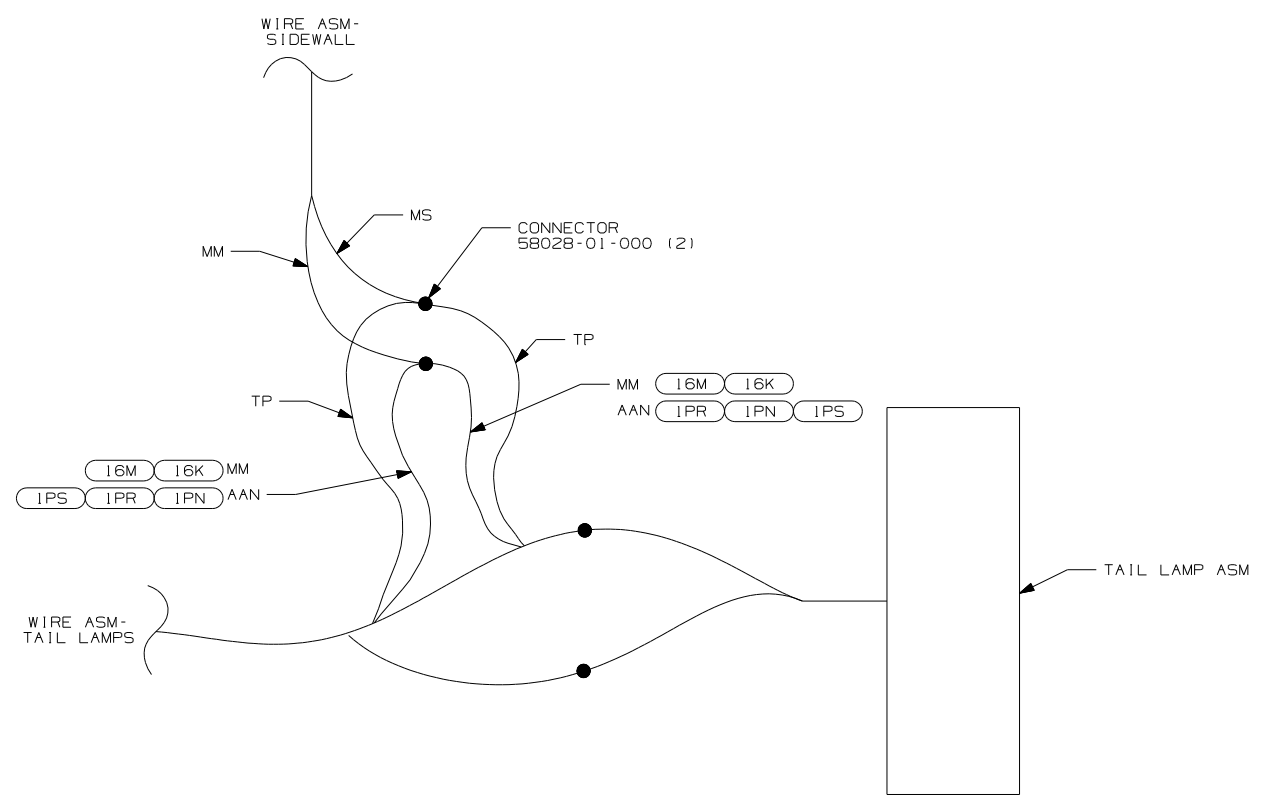

1 DETAIL CA (SHELLS ONLY)

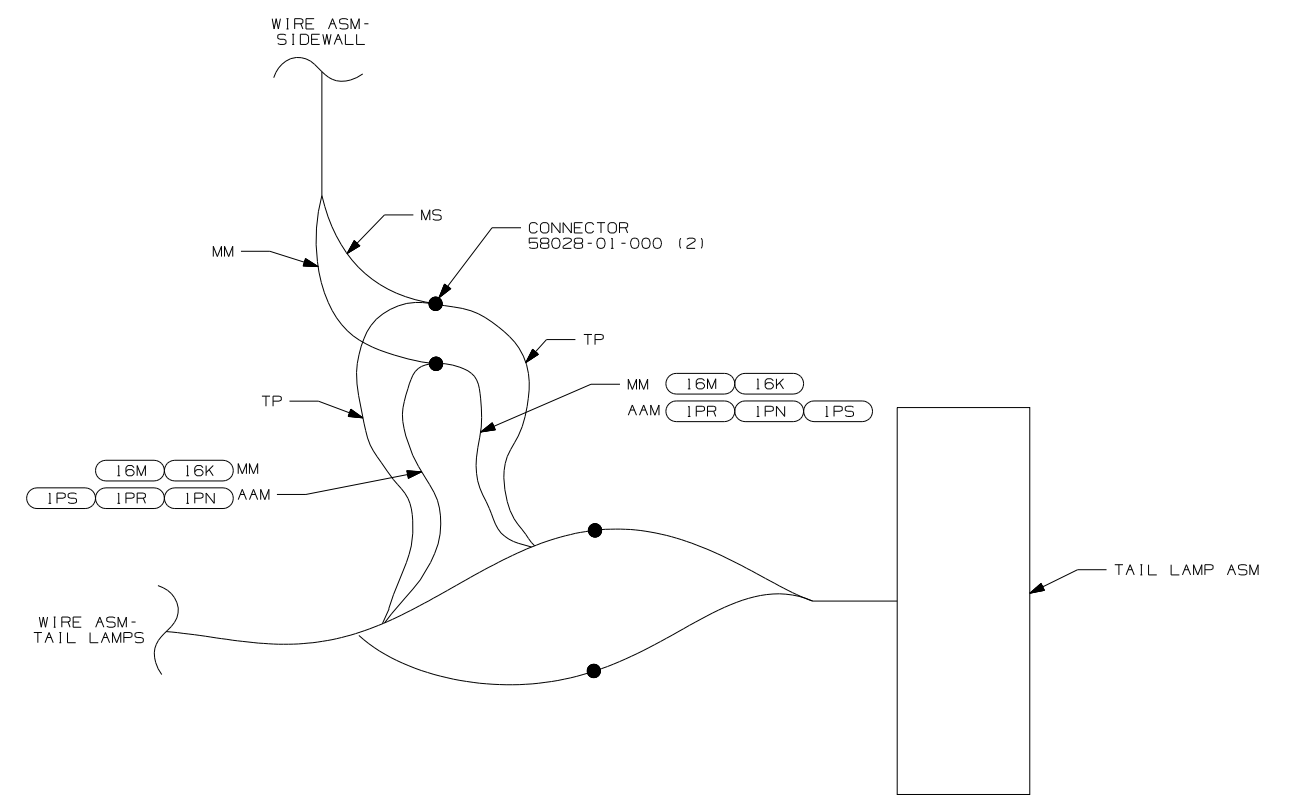

1 DETAIL CB (SHELLS ONLY)

- 16K FORD CHASSIS 22,000
- 16M FORD CHASSIS 20,500#/V10 ENG
- 16N WORKHORSE 20,700#-19.5 TIRE
- 16P WORKHORSE 22,000#
- 16S WORKHORSE 22,000#-22.5 TIRE

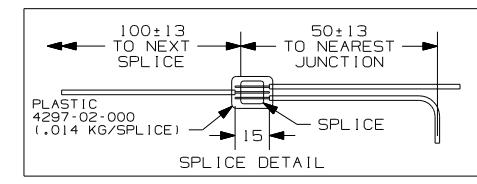

1 CUT AND RECONNECT AS SHOWN.

NOTES:

FIRST USED	04 G-SERIES
TITLE	DO NOT SCALE DRAWING
TITLE	WIRING INSTL-EXTERIOR LAMPS
SHEET 3	PART NO 144950