



DANGER

Danger of electrical shock, burns or death. Always remove all power sources before attempting any repair, service or diagnostic work. Power can be present from shore power, generator, inverter or battery. All power sources must be disabled and secured before performing any service.



CAUTION

If you lack the skills, tools or equipment to perform diagnostic or repair work leave such work to an authorized Winnebago Industries dealer or other qualified shop.

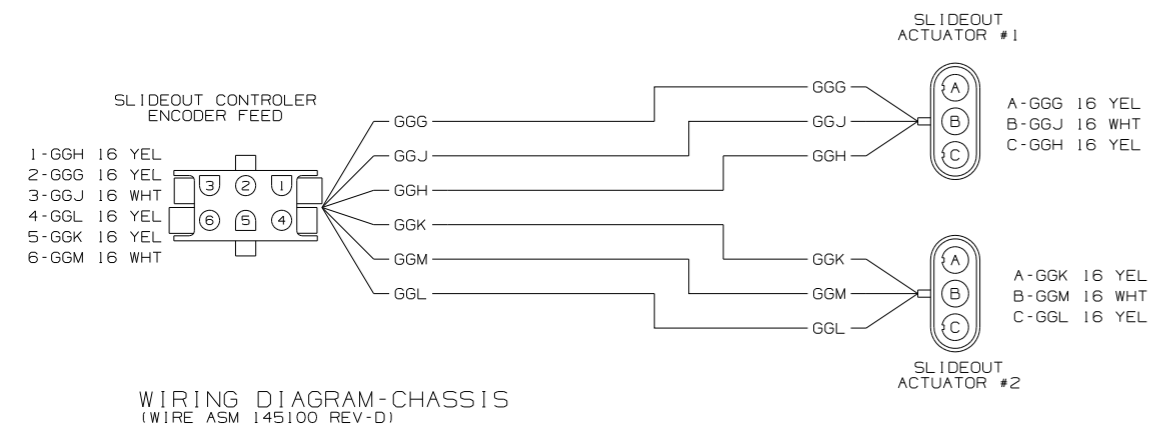
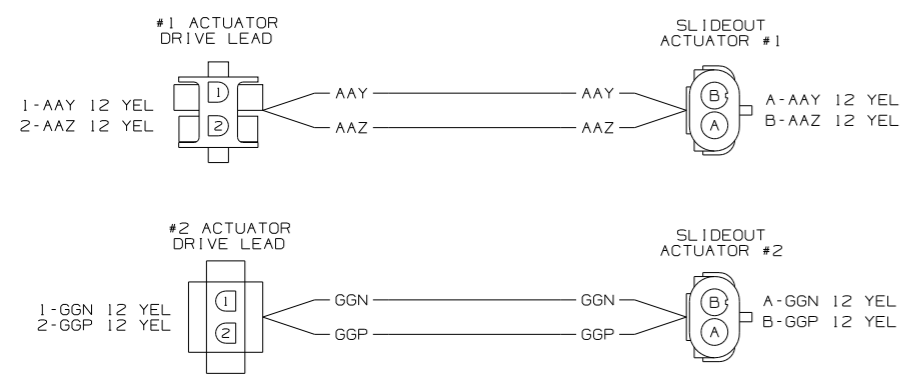
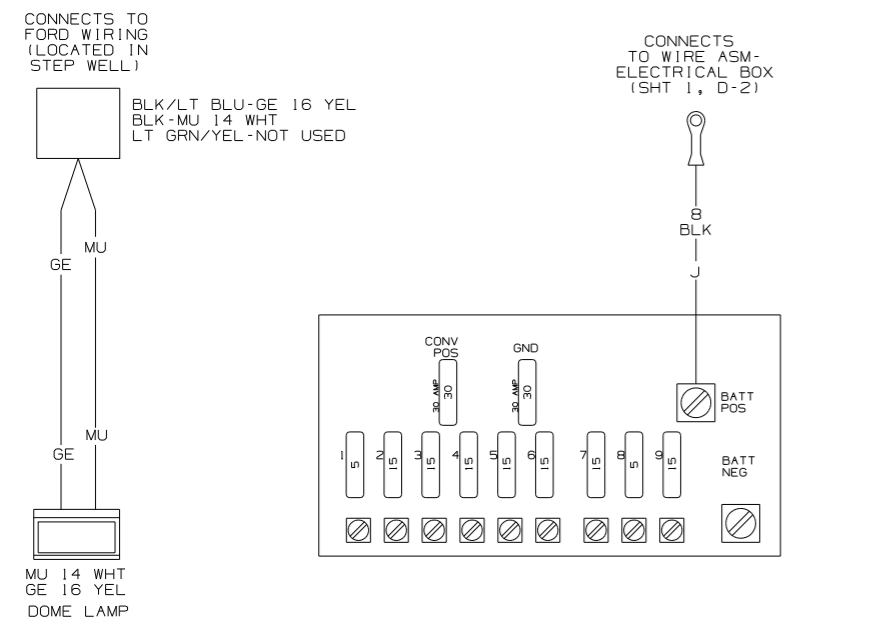

WIRING DIAGRAM-CHASSIS
(WIRE ASM 145100 REV-D)

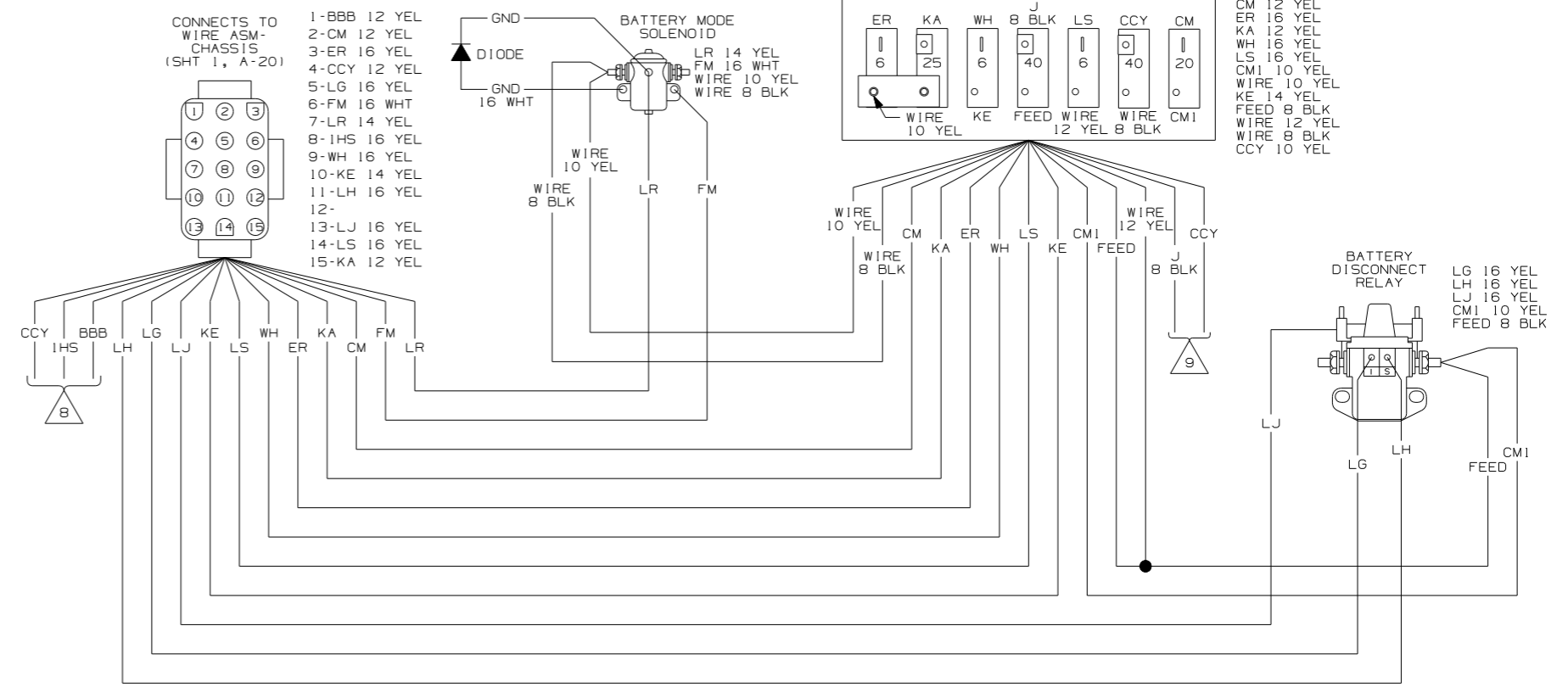

WIRING DIAGRAM-ELECTRICAL BOX
(WIRE ASM 141274 REV-J)

WINNEBAGO COPYRIGHT 2002 WINNEBAGO INDUSTRIES, INC.

DFT#	ORIG. DATE
CHR#	ALL DIMENSIONS ARE IN MILLIMETERS
P.E.	
M.E.	FIRST USED
DSNR	04 331C&T
UNSPECIFIED TOLERANCES ARE:	
WHOLE DIM (X)	:
ONE-PLACE (X.X)	:
TWO-PLACE (X.XX)	:
ANGLE	:
THIRD ANGLE PROJECTION	
DO NOT SCALE DRAWING	
TITLE: WIRING DIAGRAM-BODY, 12V	
SHEET 1 of 6	PART NO 145098

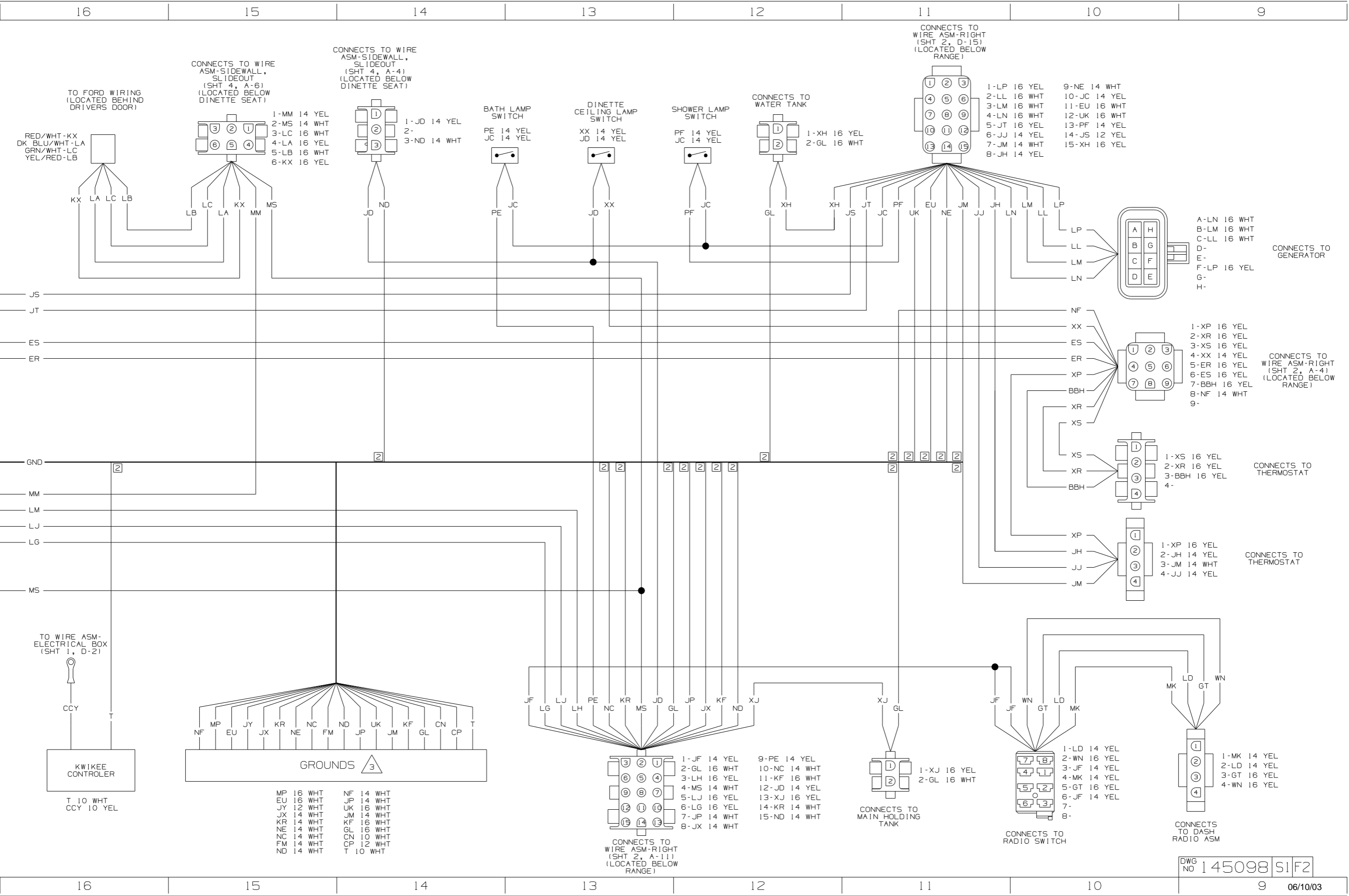

TO FORD WIRING
(LOCATED BEHIND
DRIVERS DOOR)

CONNECTS TO WIRE
ASM-SIDEWALL,
SLIDEOUT
(SHT 4, A-6)
(LOCATED BELOW
DINETTE SEAT)

CONNECTS TO WIRE
ASM-SIDEWALL,
SLIDEOUT
(SHT 4, A-4)
(LOCATED BELOW
DINETTE SEAT)

CONNECTS TO
WATER TANK

CONNECTS TO
WIRE ASM-RIGHT
(SHT 2, D-15)
(LOCATED BELOW
RANGE)

CONNECTS TO
GENERATOR

CONNECTS TO
WIRE ASM-RIGHT
(SHT 2, A-4)
(LOCATED BELOW
RANGE)

CONNECTS TO
THERMOSTAT

CONNECTS TO
THERMOSTAT

CONNECTS TO
WIRE ASM-RIGHT
(SHT 2, A-11)
(LOCATED BELOW
RANGE)

CONNECTS TO
RADIO SWITCH

CONNECTS
TO DASH
RADIO ASM

CONNECTS TO
MAIN HOLDING
TANK

TO WIRE ASM-
ELECTRICAL BOX
(SHT 1, D-2)

KWIKEE
CONTROLLER

3
GROUNDS

- | | |
|-----------|-----------|
| MP 16 WHT | NF 14 WHT |
| EU 16 WHT | JP 14 WHT |
| JY 12 WHT | UK 16 WHT |
| JX 14 WHT | JM 14 WHT |
| KR 14 WHT | KF 16 WHT |
| NE 14 WHT | GL 16 WHT |
| NC 14 WHT | CN 10 WHT |
| FM 14 WHT | CP 12 WHT |
| ND 14 WHT | T 10 WHT |

- | | | |
|----|----|----|
| 3 | 2 | 1 |
| 6 | 5 | 4 |
| 9 | 8 | 7 |
| 12 | 11 | 10 |
| 15 | 14 | 13 |

- | | |
|-------------|--------------|
| 1-JF 14 YEL | 9-PE 14 YEL |
| 2-GL 16 WHT | 10-NC 14 WHT |
| 3-LH 16 YEL | 11-KF 16 WHT |
| 4-MS 14 WHT | 12-JD 14 YEL |
| 5-LJ 16 YEL | 13-XJ 16 YEL |
| 6-LG 16 YEL | 14-KR 14 WHT |
| 7-JP 14 WHT | 15-ND 14 WHT |
| 8-JX 14 WHT | |

- | | |
|---|---|
| 7 | 8 |
| 4 | 1 |
| 5 | 2 |
| 6 | 3 |
| 7 | 4 |
| 8 | |

- | | | | |
|---|---|---|---|
| 1 | 2 | 3 | 4 |
|---|---|---|---|

- | | |
|-------------|-------------|
| 1-LD 14 YEL | 1-MK 14 YEL |
| 2-WN 16 YEL | 2-LD 14 YEL |
| 3-JF 14 YEL | 3-GT 16 YEL |
| 4-MK 14 YEL | 4-WN 16 YEL |
| 5-GT 16 YEL | |
| 6-JF 14 YEL | |
| 7- | |
| 8- | |

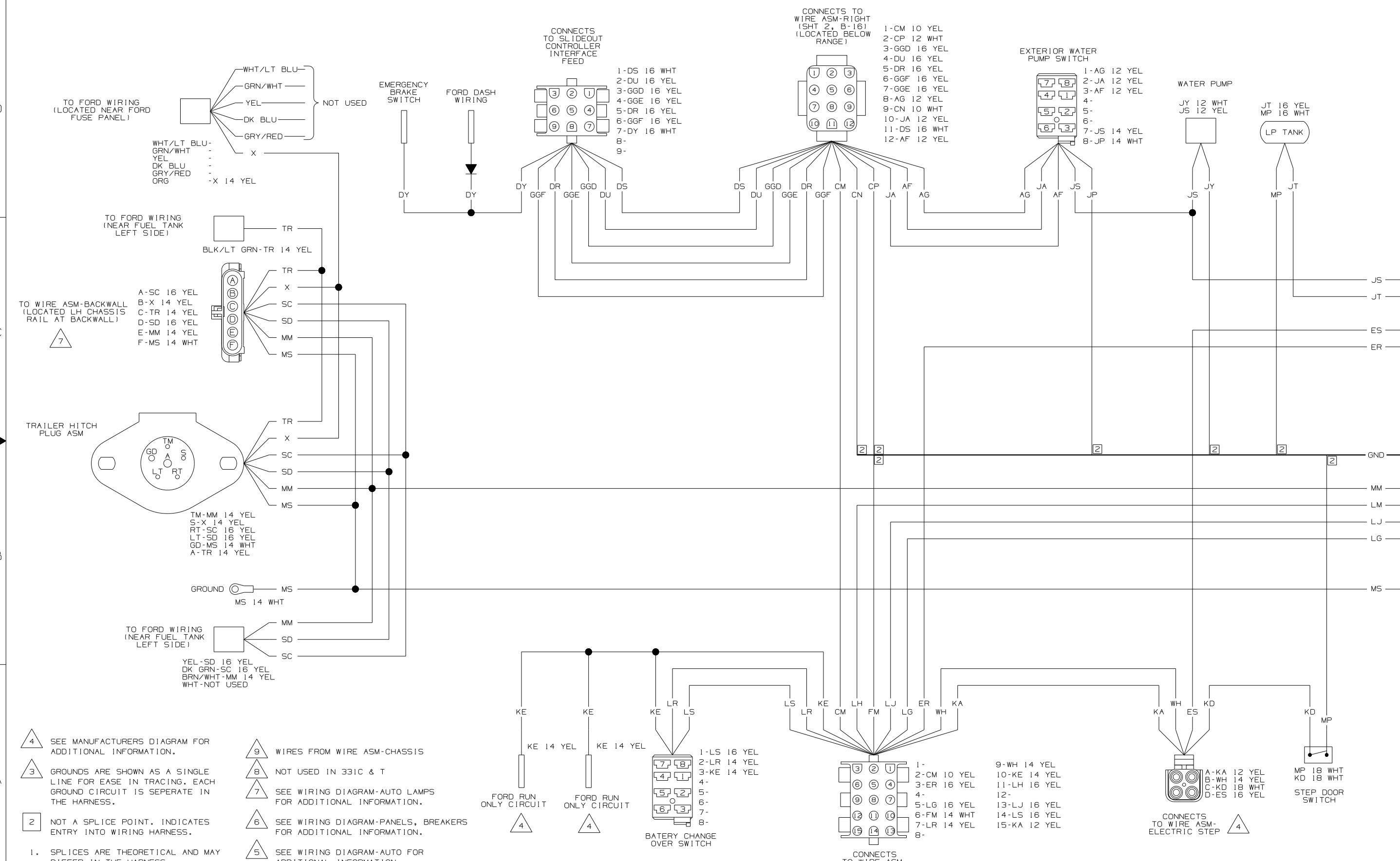

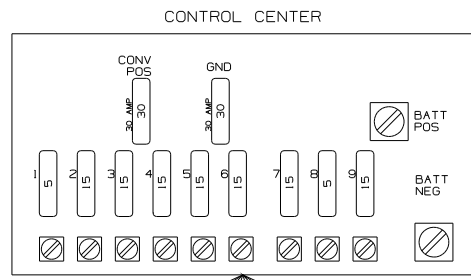

ET 16 YEL
JC 14 YEL
JD 14 YEL
JE 14 YEL
JF 14 YEL
JA 12 YEL
WB 16 YEL

CONNECTS TO WIRE ASM-SIDEWALL (SHT 4, C-8) (LOCATED LOWER WARDROBE CABT)

CONNECTS TO WIRE ASM-SIDEWALL, RIGHT (SHT 5, D-7) (LOCATED LOWER WARDROBE CABT) (331T ONLY)

CONNECTS TO WIRE ASM-ENTERTAINMENT CENTER (SHT 5, D-1) (LOCATED BEHIND EXT ENT CTR)

CONNECTS TO RANGE HOOD

CONNECTS TO WIRE ASM-ROOF (SHT 3, C-8) (LOCATED IN GALLEY OVHD)

BEDROOM CEILING LAMP SWITCH

PORCH LAMP SWITCH

LOUNGE LAMP SWITCH

HALL LAMP SWITCH

1-JA 14 YEL
2-JP 14 WHT

1-JA 14 YEL
2-JP 14 WHT

1-JA 14 YEL
2-JP 14 WHT

1-JA 14 YEL
2-JP 14 WHT
3-JP 14 WHT

1-JE 14 YEL
2-NE 14 WHT
3-PL 14 YEL
4-MM 14 YEL
5-MS 14 WHT
6-XX 14 YEL

7-JC 14 YEL
8-NC 14 WHT
9-ND 14 WHT
10-PE 14 YEL
11-PC 14 YEL
12-PF 14 YEL

JC 14 YEL
PC 14 YEL

JE 14 YEL
PJ 14 YEL

JE 14 YEL
PL 14 YEL

JE 14 YEL
WX 14 YEL

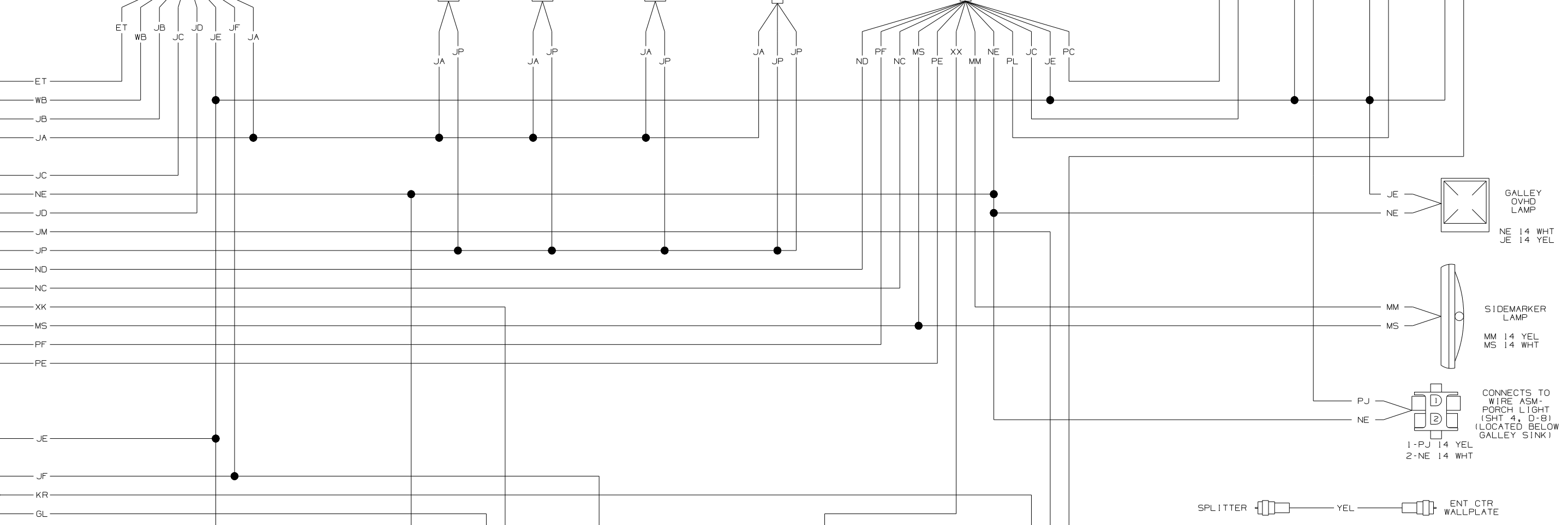

GALLEY OVHD LAMP
NE 14 WHT
JE 14 YEL

SIDEMARKER LAMP
MM 14 YEL
MS 14 WHT

CONNECTS TO WIRE ASM-PORCH LIGHT (SHT 4, D-8) (LOCATED BELOW GALLEY SINK)

1-PJ 14 YEL
2-NE 14 WHT

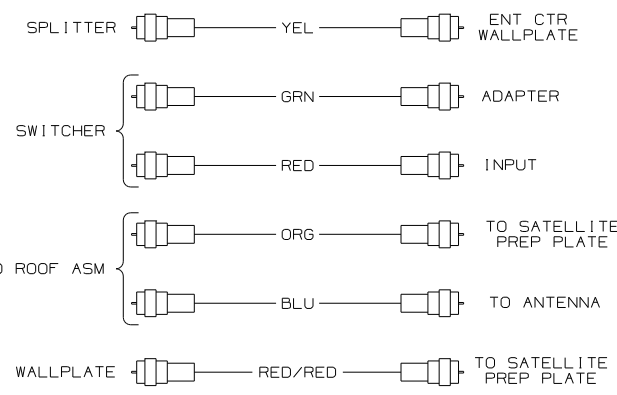

NY 14 YEL
JE 14 YEL
NU 14 YEL
AISLE LAMP SWITCH

NY 14 YEL
PH 14 YEL
NU 14 YEL
AISLE LAMP SWITCH

NE 14 WHT
PH 14 YEL
AISLE LAMP

NE 14 WHT
PH 14 YEL
AISLE LAMP

1-XK 16 YEL
2-GL 16 WHT

1-JF 14 YEL
2-NF 14 YEL

ES 16 YEL
ER 16 YEL
ELECTRIC STEP KILL SWITCH

1-XP 16 YEL
2-XR 16 YEL
3-XS 16 YEL
4-XX 14 YEL
5-ER 16 YEL
6-ES 16 YEL
7-BBH 16 YEL
8-NF 14 YEL
9-

1-JM 14 WHT
2-XP 16 YEL
3-XR 16 YEL
4-XS 16 YEL
5-KR 14 WHT
6-WX 14 YEL
7-BBH 16 YEL
8-
9-

CONNECTS TO WIRE ASM-CHASSIS (SHT 1, C-10) (LOCATED BELOW RANGE)

CONNECTS TO WIRE ASM-ROOF (SHT 3, C-8) (LOCATED IN GALLEY OVHD)

WIRING DIAGRAM-RIGHT (WIRE ASM 145101 REV-D)

FIRST USED 04 331C&T

DO NOT SCALE DRAWING

TITLE: WIRING DIAGRAM-BODY, 12V

SHEET 2 PART NO 145098

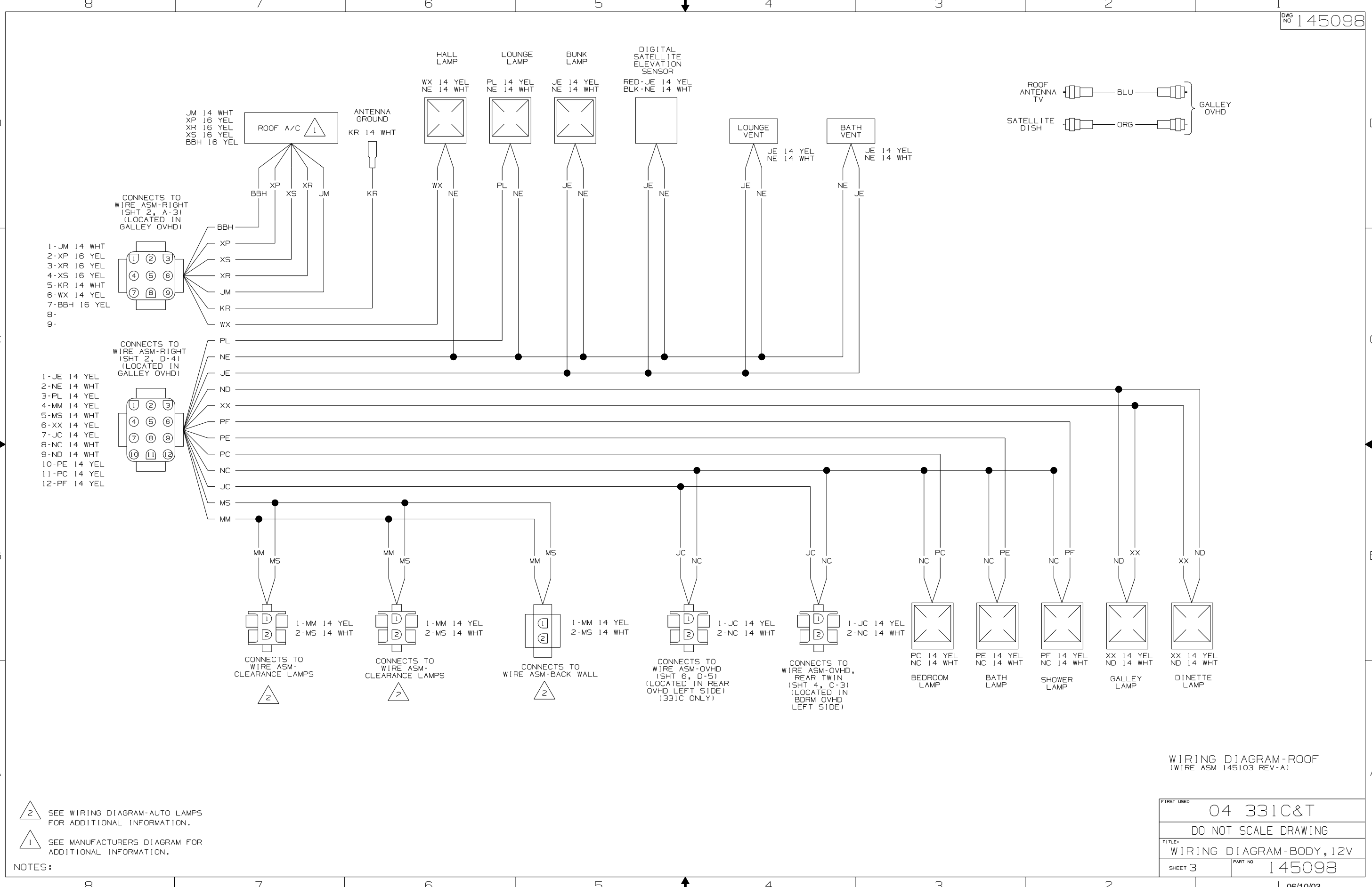

- CONNECTS TO WIRE ASM-RIGHT (SHT 2, A-3) (LOCATED IN GALLEY OVHD)
- 1-JM 14 WHT
 - 2-XP 16 YEL
 - 3-XR 16 YEL
 - 4-XS 16 YEL
 - 5-KR 14 WHT
 - 6-WX 14 YEL
 - 7-BBH 16 YEL
 - 8-
 - 9-

- CONNECTS TO WIRE ASM-RIGHT (SHT 2, D-4) (LOCATED IN GALLEY OVHD)
- 1-JE 14 YEL
 - 2-NE 14 WHT
 - 3-PL 14 YEL
 - 4-MM 14 YEL
 - 5-MS 14 WHT
 - 6-XX 14 YEL
 - 7-JC 14 YEL
 - 8-NC 14 WHT
 - 9-ND 14 WHT
 - 10-PE 14 YEL
 - 11-PC 14 YEL
 - 12-PF 14 YEL

NOTES:

△ SEE WIRING DIAGRAM-AUTO LAMPS FOR ADDITIONAL INFORMATION.

△ SEE MANUFACTURERS DIAGRAM FOR ADDITIONAL INFORMATION.

WIRING DIAGRAM-ROOF
(WIRE ASM 145103 REV-A)

FIRST USED	04 331C&T
TITLE	DO NOT SCALE DRAWING
WIRING DIAGRAM-BODY, 12V	
SHEET 3	PART NO 145098

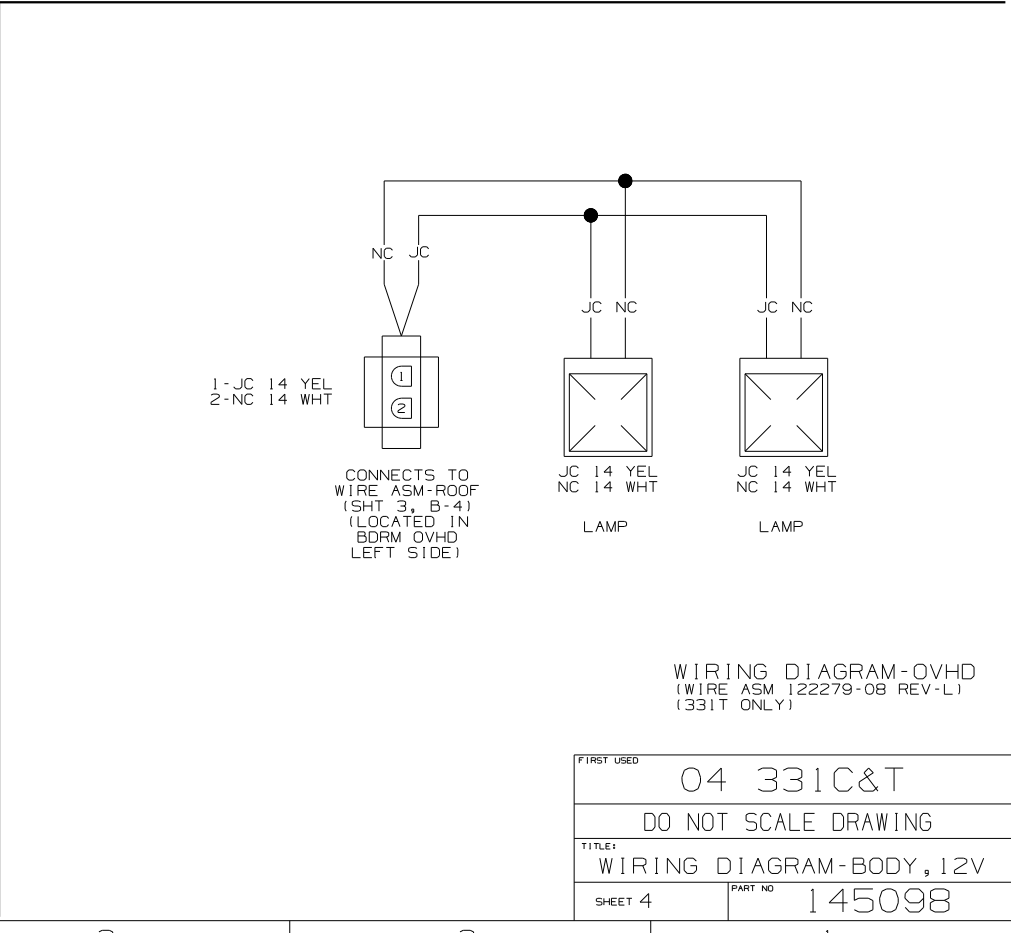
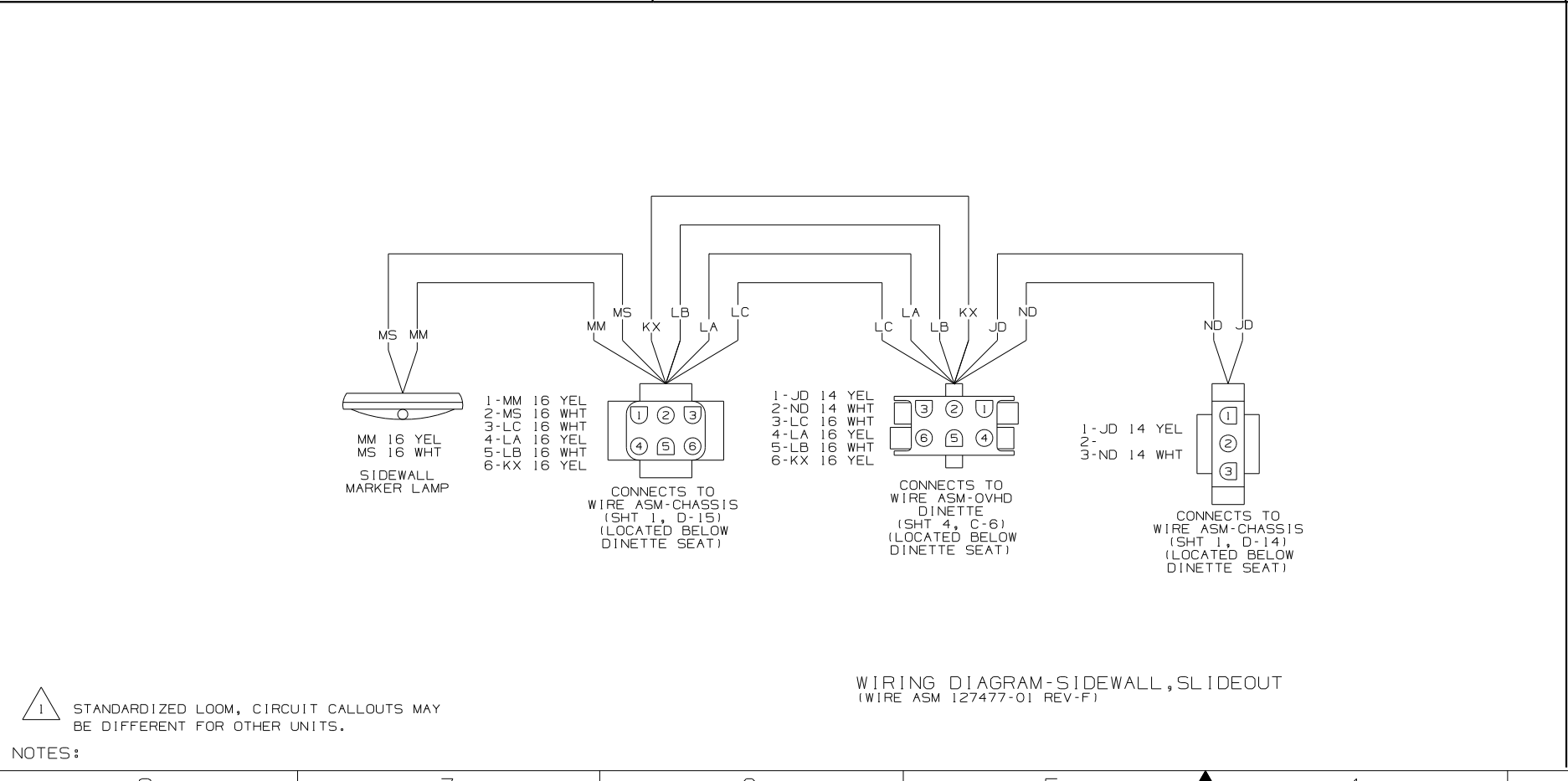
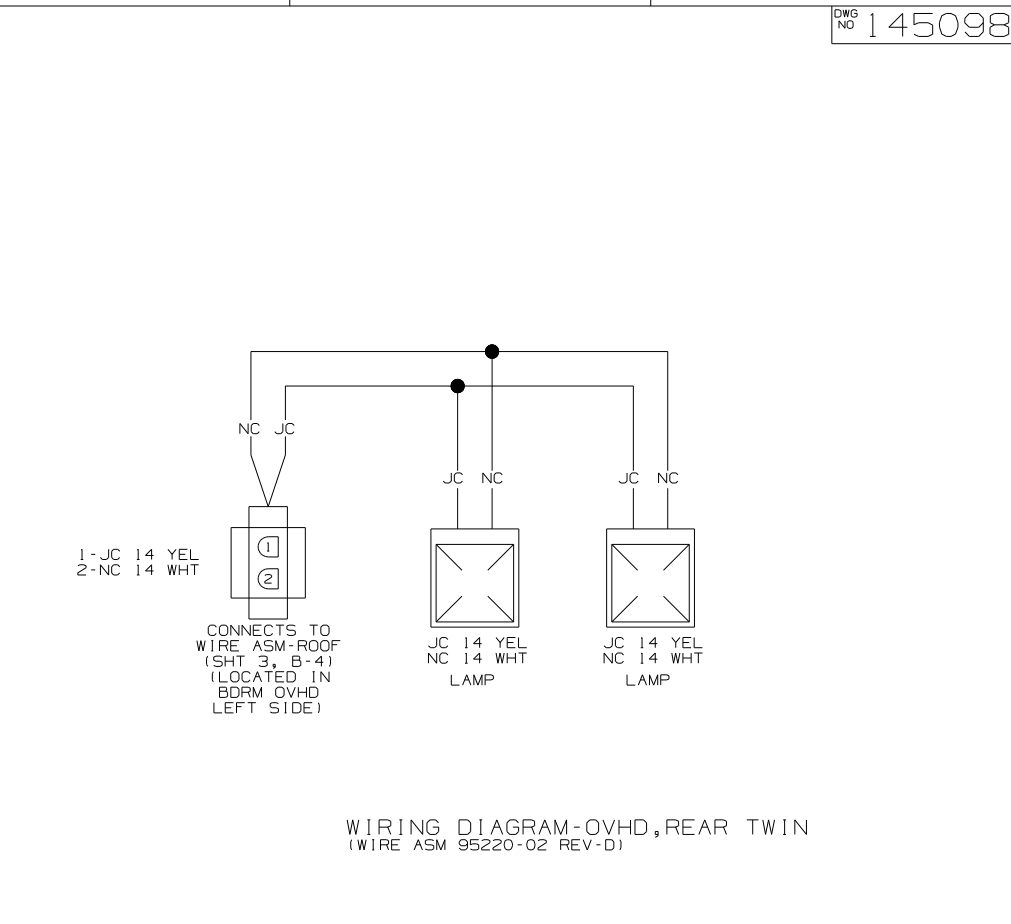
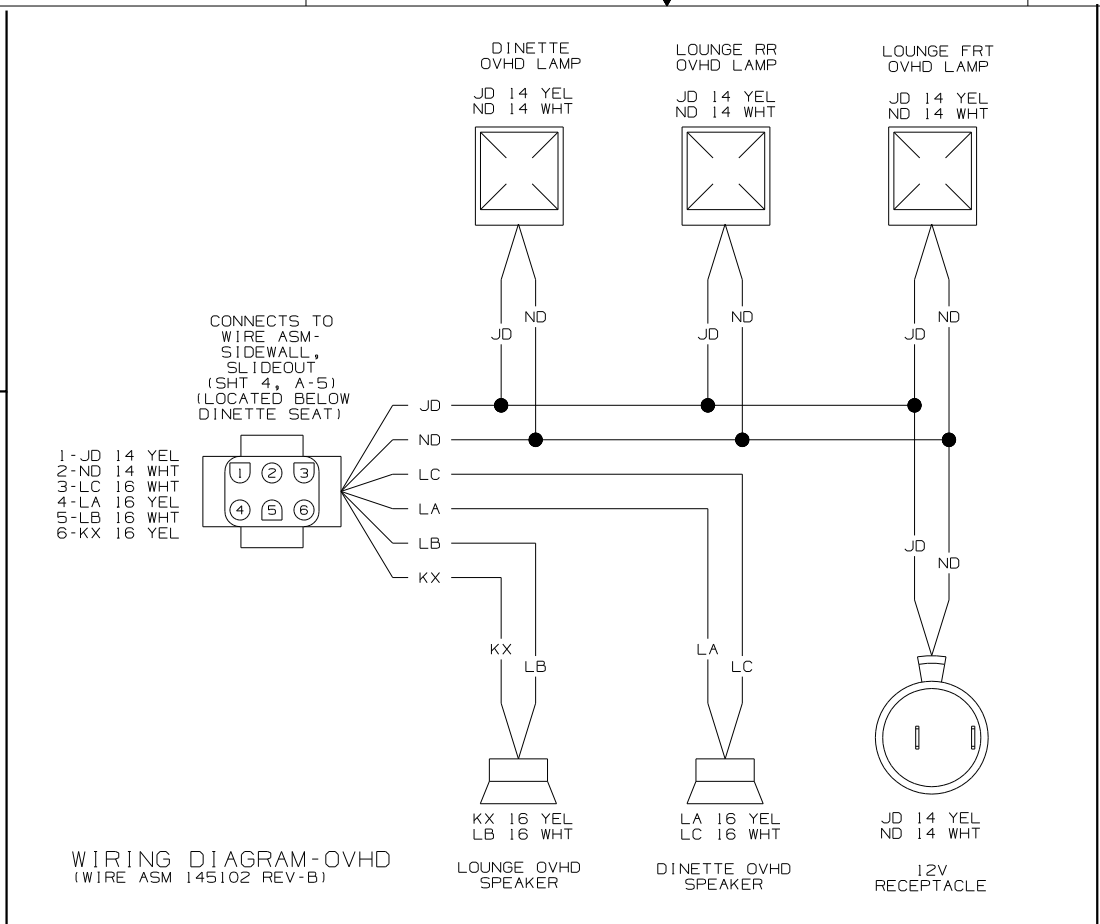
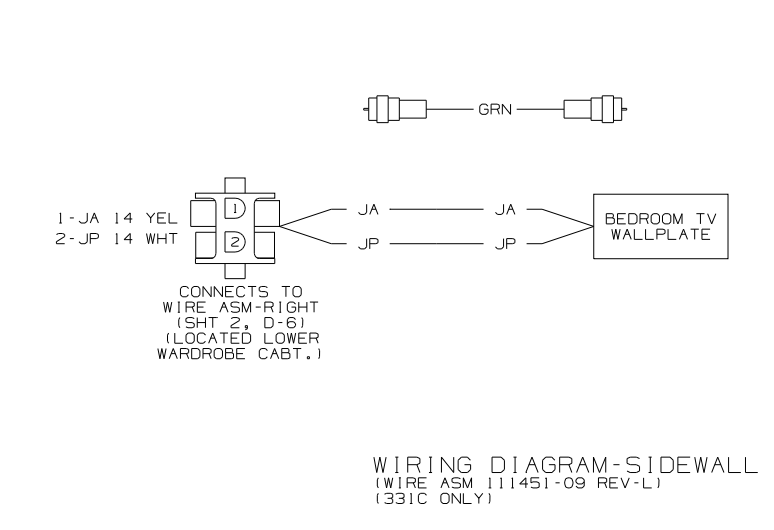
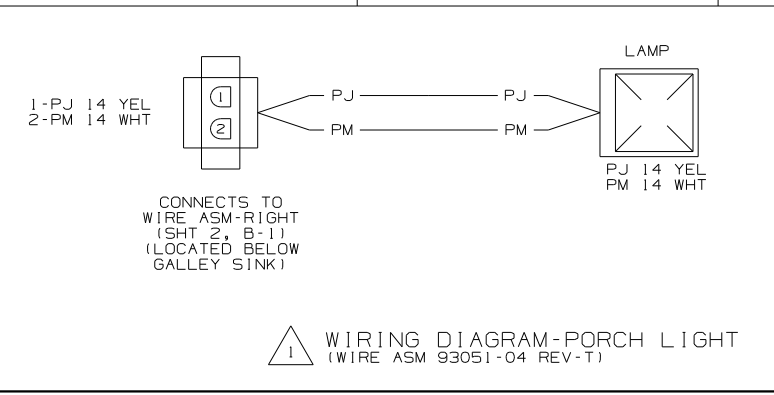

NOTES:
1 STANDARDIZED LOOM, CIRCUIT CALLOUTS MAY BE DIFFERENT FOR OTHER UNITS.

FIRST USED	04 331C&T
TITLE	DO NOT SCALE DRAWING
TITLE	WIRING DIAGRAM-BODY, 12V
SHEET 4	PART NO 145098



WIRING DIAGRAM-ROOF,CENTER
(WIRE ASM 77093-16 REV-AG)

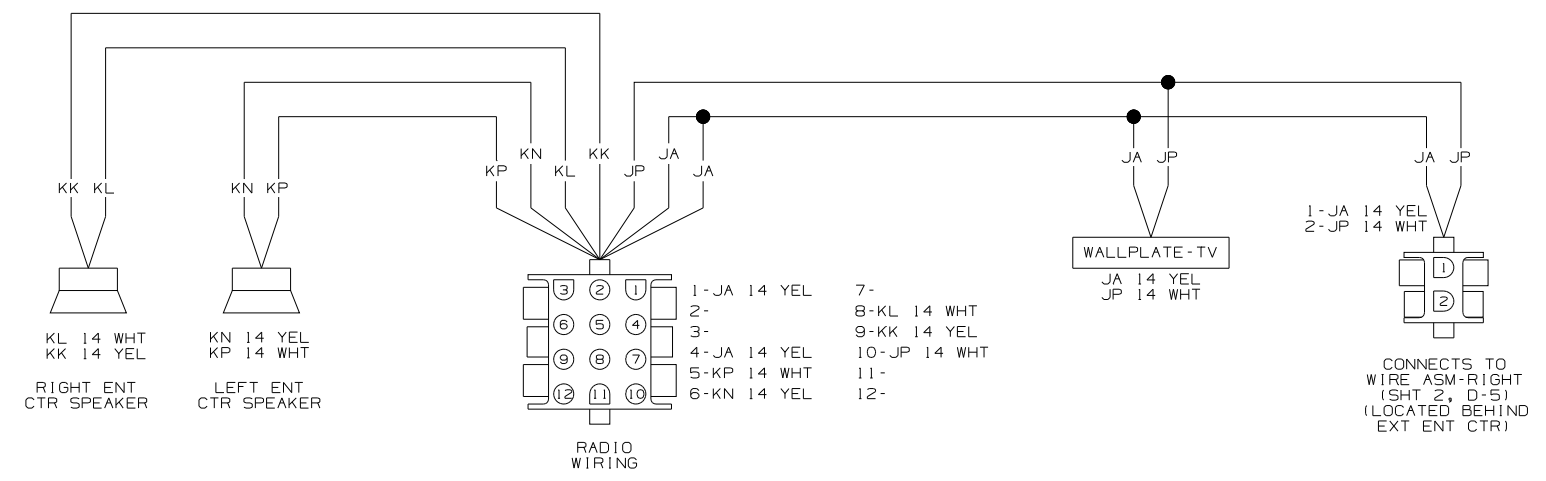

WIRING DIAGRAM-ENTERTAINMENT CENTER
(WIRE ASM 125853-04 REV-L)

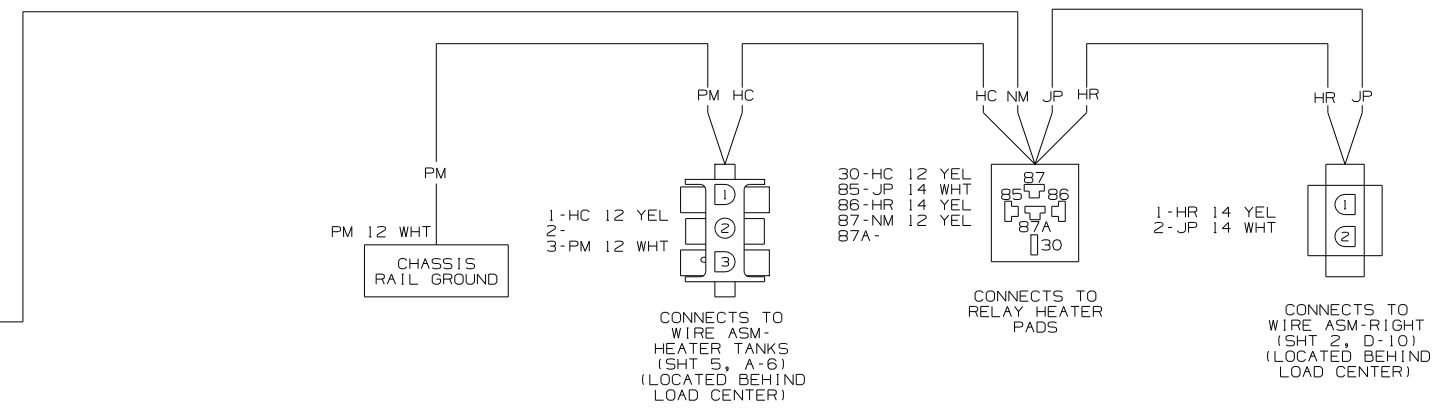
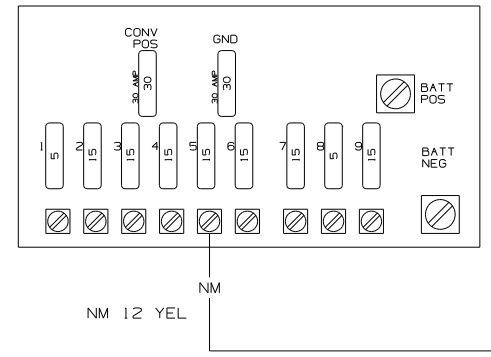

WIRING DIAGRAM-HEATER,RELAY
(WIRE ASM 134550 REV-A)

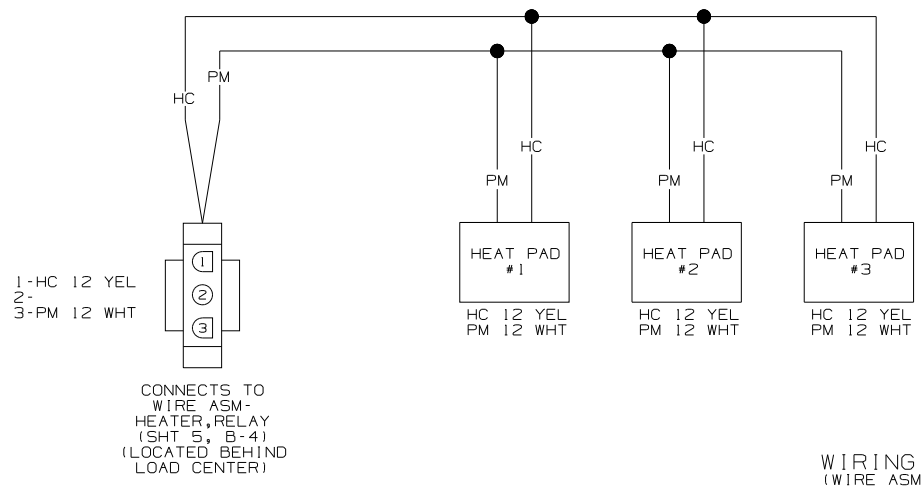

WIRING DIAGRAM-HEATER,TANKS
(WIRE ASM 134551-06 REV-D)

NOTES:
1 SEE WIRING DIAGRAM-RIGHT FOR ADDITIONAL INFORMATION. (SHT 2, D-8 OR SHT 3, D-8)

FIRST USED	04 331C&T
TITLE	DO NOT SCALE DRAWING
TITLE	WIRING DIAGRAM-BODY,12V
SHEET 5	PART NO 145098

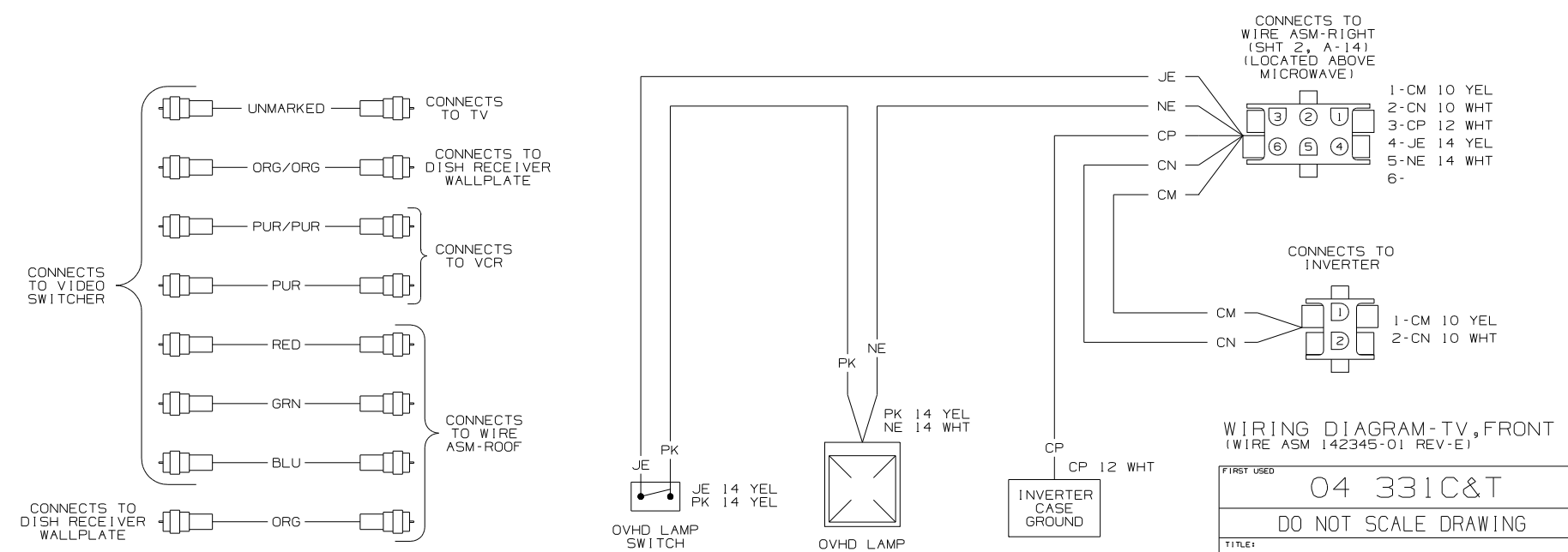
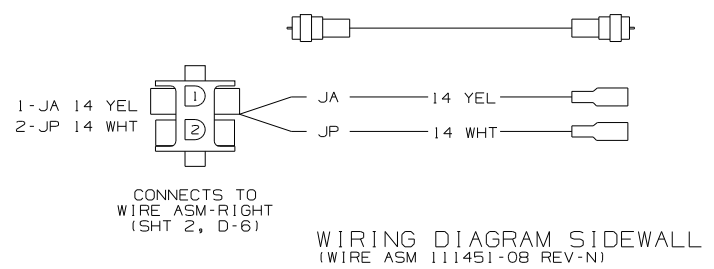
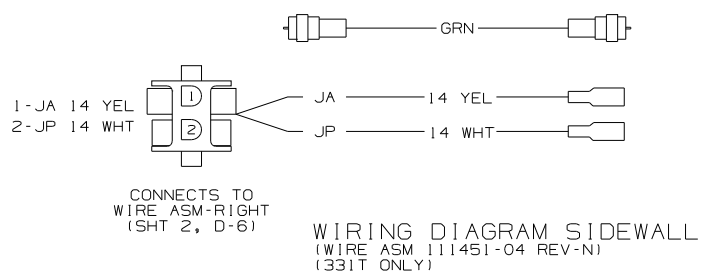
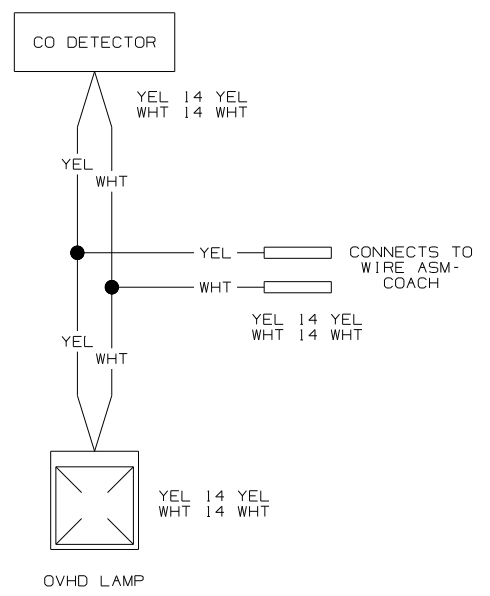
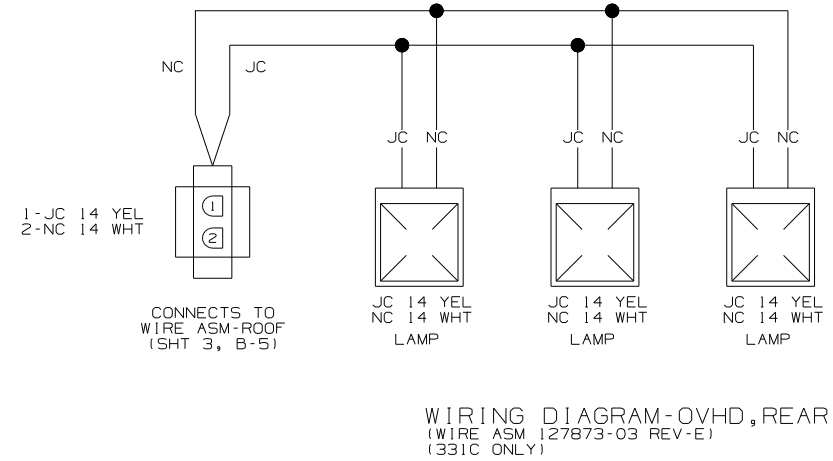

NOTES:
 2 SEE WIRING DIAGRAM-AUTO FOR ADDITIONAL INFORMATION.
 1 SEE MANUFACTURERS DIAGRAM FOR ADDITIONAL INFORMATION.

FIRST USED	04 331C&T
TITLE	DO NOT SCALE DRAWING
	WIRING DIAGRAM-BODY, 12V
SHEET 6	PART NO 145098