

FRONT OF VEHICLE

- (1B1) CODES/STANDARDS-USA
- (265) CODES/STANDARDS-CSA/CMVSS
- (43M) TOILET PORCELAIN-ELONGATED
- (21M) WASHER/DRYER PREP
- (54E) WASHER/DRYER

- △ 8 FASTEN TO BOTTOM OF UPPER FLOOR.
- △ 7 VENT PIPE MUST PROJECT 51 MIN AND 63.5 MAX ABOVE ROOF FOR PROPER FIT AND FUNCTION.

6. SEE DWG 61607-01-000 FOR INSTL OF GROMMETS
5. SEAL AROUND SHOWER WITH SILICONE.
4. ALL EXTERIOR OPENINGS AROUND PIPE TO BE SEALED WITH 110744-01-000.
3. ALL PIPE AND FITTINGS TO BE ASSEMBLED WITH SOLVENT 4020-01-000.
2. SLOPE OF TRAP ARM MUST BE 6 PER 305 MM.
1. SLOPE OF HORIZONTAL PIPING TO BE 6 PER 305 MM.

NOTES:

(X-X)
FOR DRAINAGE CALLOUTS SEE DWG NO 116229-01-000

WINNEBAGO		COPYRIGHT 2003 WINNEBAGO INDUSTRIES, INC.	
DFTR	ORIG. DATE	ALL DIMENSIONS ARE IN MILLIMETERS	
CHKR		FIRST USED	
P.E.		03 P36GD	
M.E.		UNSPECIFIED TOLERANCES ARE:	
DSNR		MATERIAL:	
		WHOLE DIM (X)	: 7
		ONE-PLACE (X.X)	:
		TWO-PLACE (X.XX)	:
		ANGLE	:
THIRD ANGLE PROJECTION			
DO NOT SCALE DRAWING			
TITLE: DRAINAGE SYSTEM INSTL			
SHEET 1 OF 3	PART NO	142754	
REF: 139561 03/12/03			

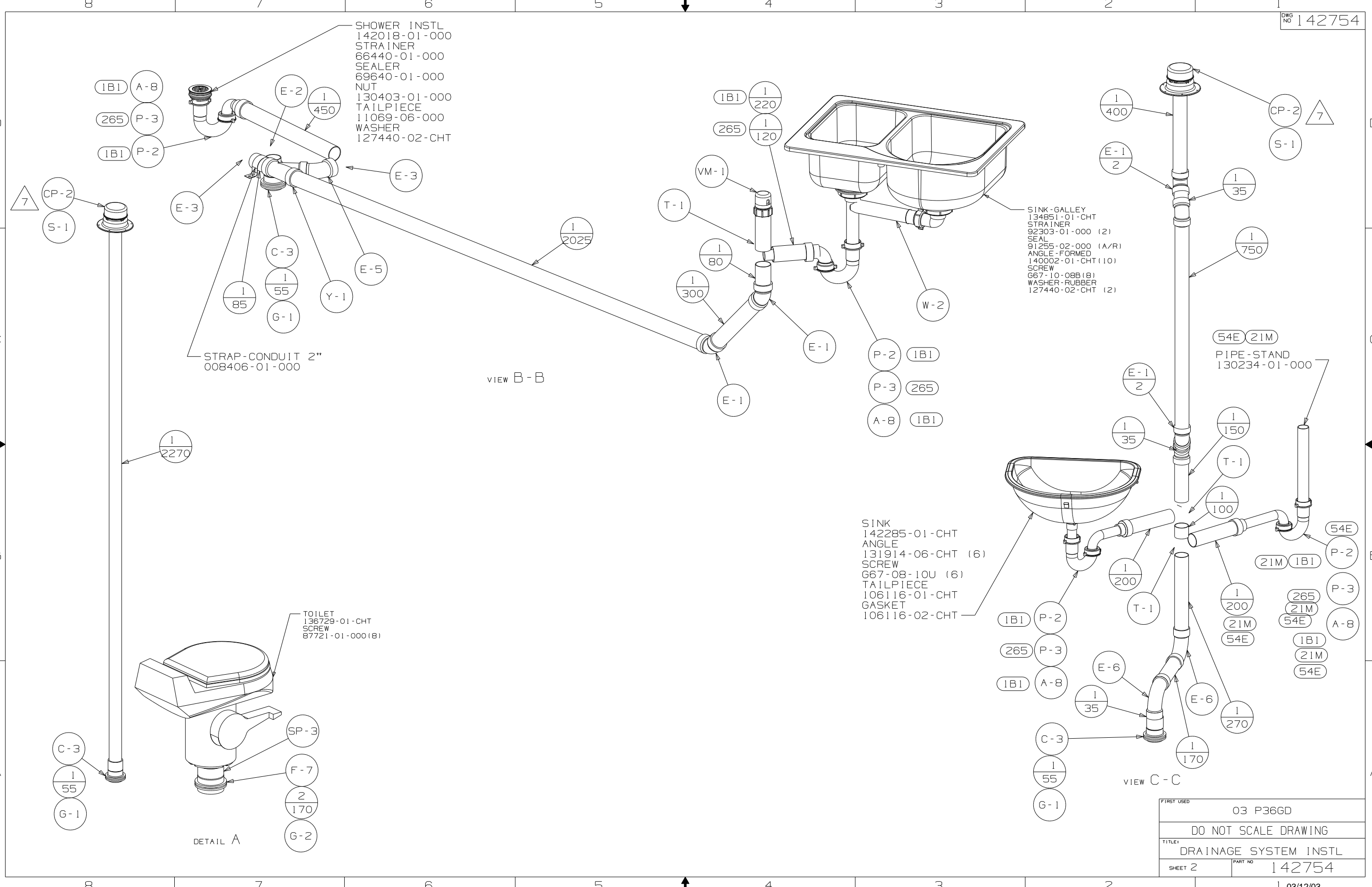

- SHOWER INSTL
 142018-01-000
 STRAINER
 66440-01-000
 SEALER
 69640-01-000
 NUT
 130403-01-000
 TAILPIECE
 11069-06-000
 WASHER
 127440-02-CHT

- SINK-GALLEY
 134851-01-CHT
 STRAINER
 92303-01-000 (2)
 SEAL
 91255-02-000 (A/R)
 ANGLE-FORMED
 140002-01-CHT (10)
 SCREW
 G67-10-08B (8)
 WASHER-RUBBER
 127440-02-CHT (2)

- SINK
 142285-01-CHT
 ANGLE
 131914-06-CHT (6)
 SCREW
 G67-08-10U (6)
 TAILPIECE
 106116-01-CHT
 GASKET
 106116-02-CHT

- TOILET
 136729-01-CHT
 SCREW
 87721-01-000 (8)

STRAP-CONDUIT 2"
 008406-01-000

54E 21M
 PIPE-STAND
 130234-01-000

VIEW B-B

VIEW C-C

DETAIL A

FIRST USED	03 P36GD
DO NOT SCALE DRAWING	
TITLE	DRAINAGE SYSTEM INSTL
SHEET 2	PART NO 142754

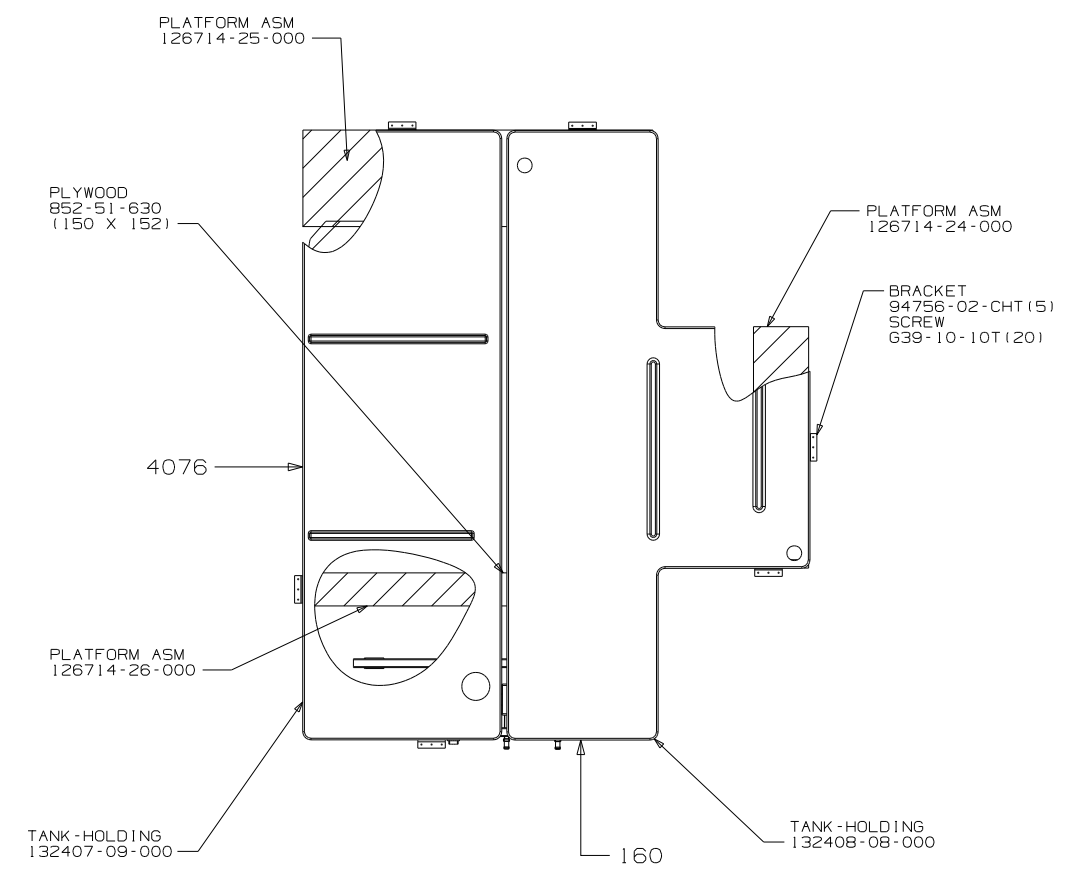
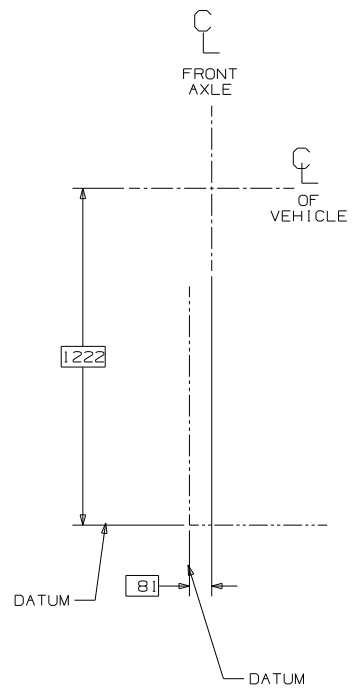

VIEW D

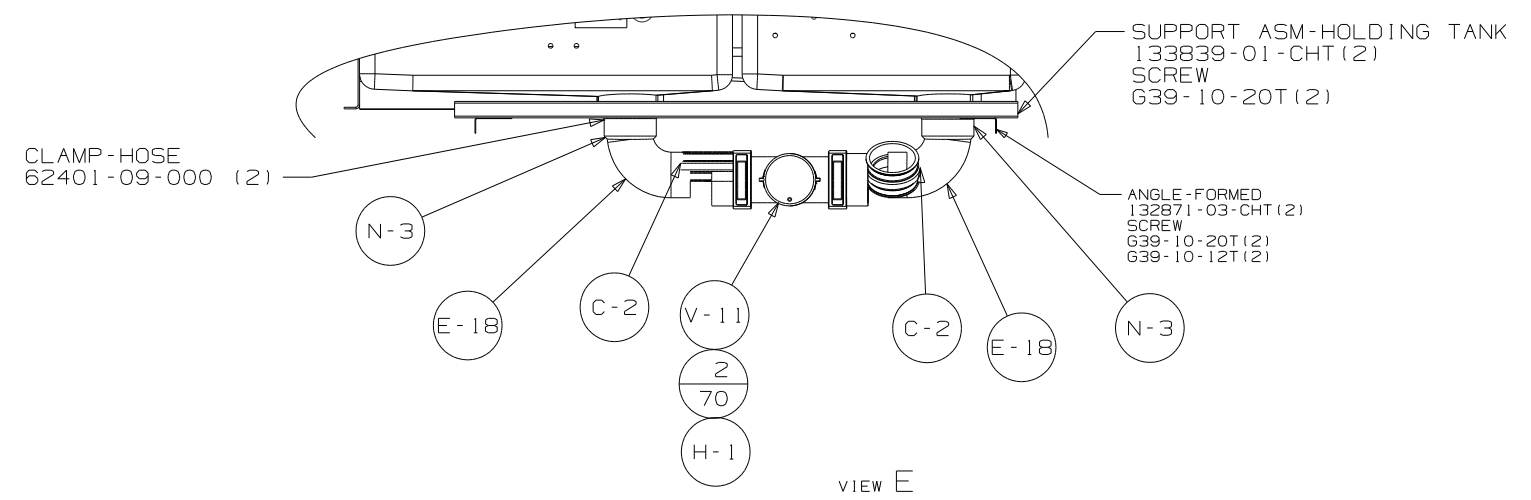

VIEW E

FIRST USED	03 P36GD
DO NOT SCALE DRAWING	
TITLE	DRAINAGE SYSTEM INSTL
SHEET 3	PART NO 142754

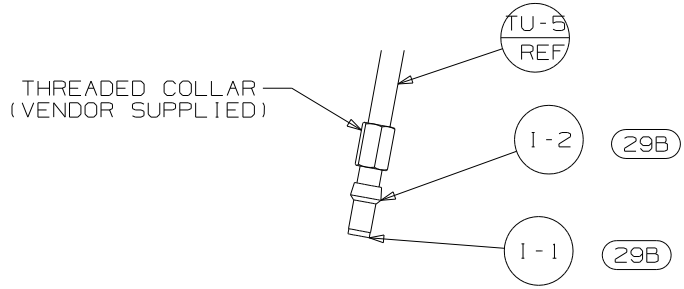

WATER FILTER
CONNECTION DETAIL

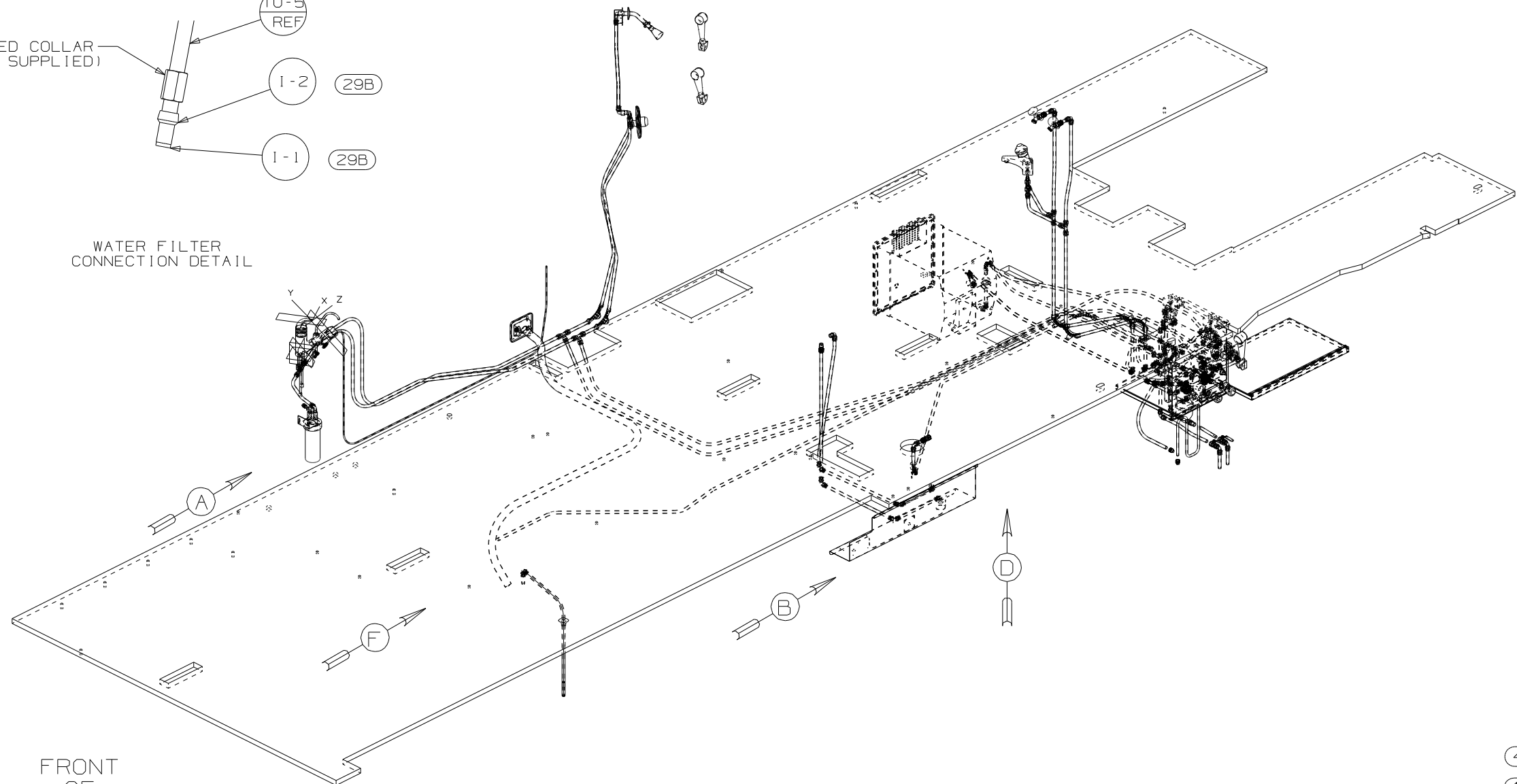

- (43H) SHOWER HEAD - HAND HELD
- (43A) SHOWER HEAD FIXED
- (9B1) SHOWER PACKAGE
- (29B) WATER PURIFIER

- NOTES:
7. ADD TEFLON TAPE 10405-01-000 TO FITTING.
 6. ADD TEFLON TAPE 10405-03-000 TO FITTING.
 5. ADD TEFLON TAPE 10405-02-000 TO FITTING.
 4. FLUSHING SYSTEM REQUIRES 125697-06-000 INSTRUCTION SHEET.
 3. ALL TUBING TO BE SECURED AT 1200 INTERVALS MAXIMUM WITH CLAMP 10495-01-000 OR CLIP 9151-01-000 AND SCREW G67-10-12B.
 2. TUBING TO BE INSTALLED WITH SUFFICIENT SLOPE TO PROVIDE DRAINAGE TO NEAREST VALVE.
 1. PLASTIC FITTINGS TO BE SEALED WITH SEALANT 84456-01-000

WINNEBAGO		COPYRIGHT 2003 WINNEBAGO INDUSTRIES, INC.	
DFTR	ORIG. DATE	ALL DIMENSIONS ARE IN MILLIMETERS	
CHKR		FIRST USED	
P.E.		03 P36GD	
M.E.		UNSPECIFIED TOLERANCES ARE:	
DSNR		MATERIAL:	
		WHOLE DIM (X) :	7
		ONE-PLACE (X.X) :	
		TWO-PLACE (X.XX) :	
		ANGLE :	
THIRD ANGLE PROJECTION		DO NOT SCALE DRAWING	
TITLE: WATER SYSTEM INSTL			
SHEET 1 OF 4		PART NO 142743	

X-X
FOR WATER
CALLOUTS
SEE DWG NO.
116230-01-000

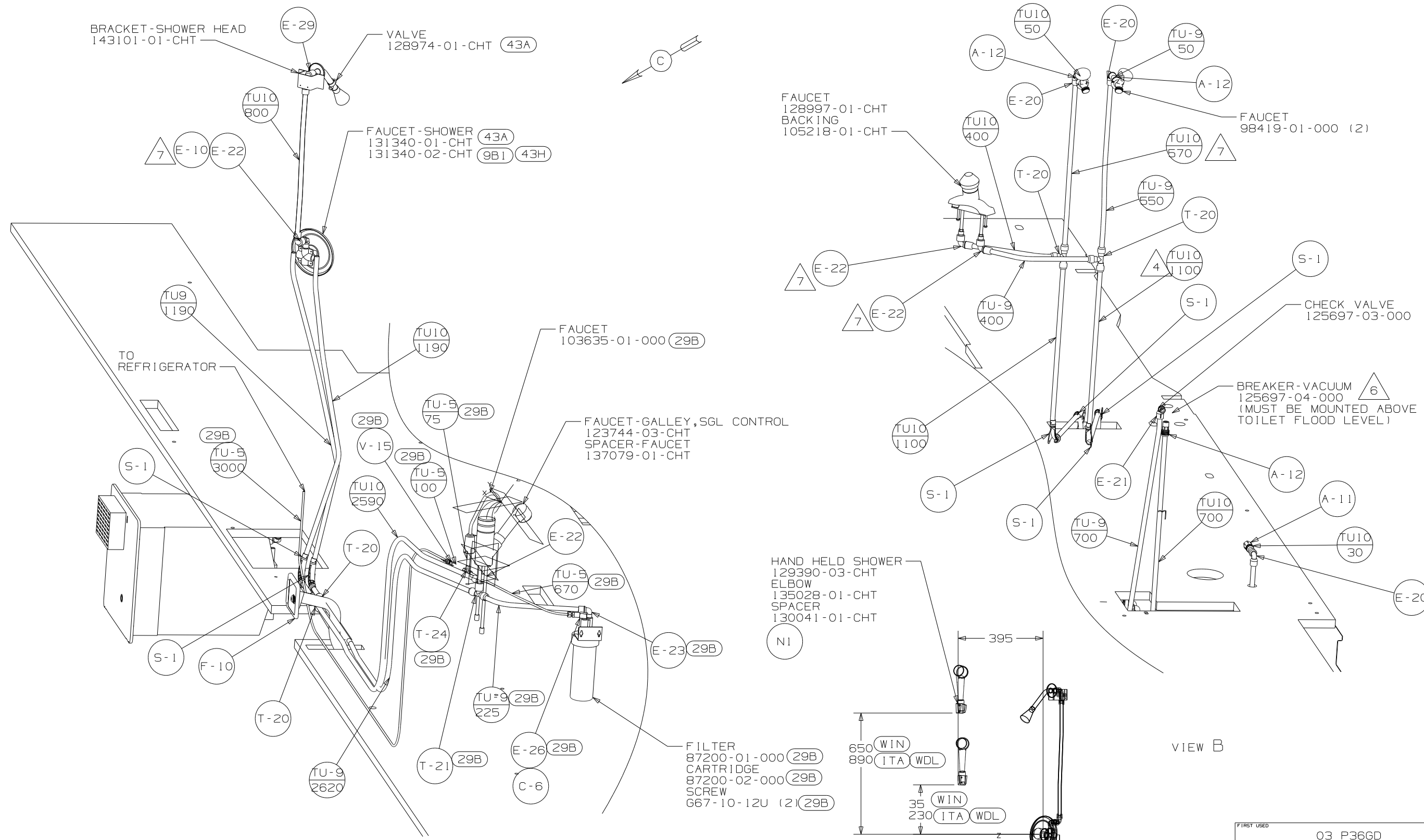

VIEW A

VIEW B

VIEW C (9B1) (43H)

FIRST USED	03 P36GD
DO NOT SCALE DRAWING	
TITLE:	WATER SYSTEM INSTL
SHEET 2	PART NO 142743

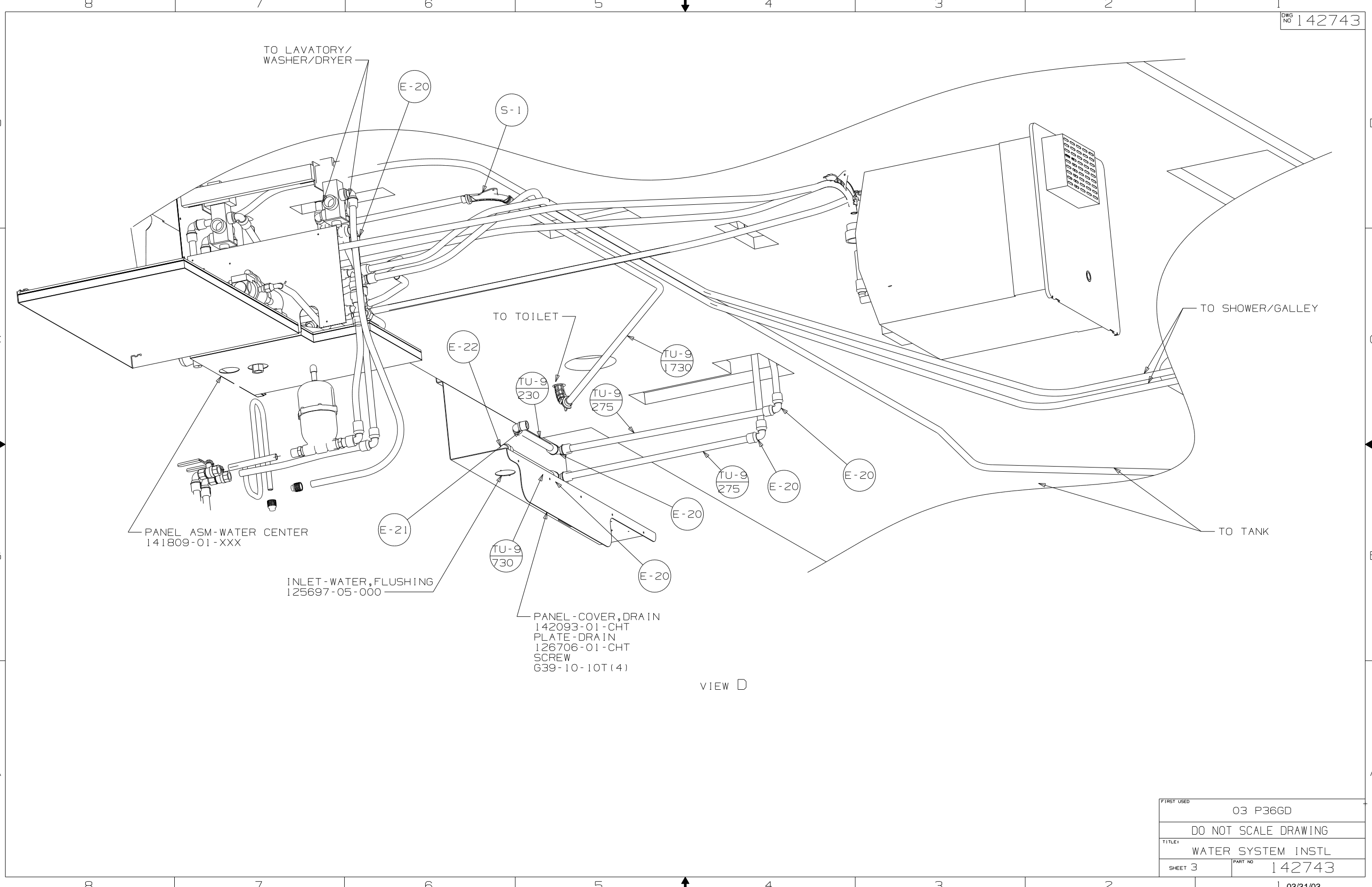

FIRST USED	03 P36GD
TITLE	DO NOT SCALE DRAWING
	WATER SYSTEM INSTL
SHEET 3	PART NO 142743

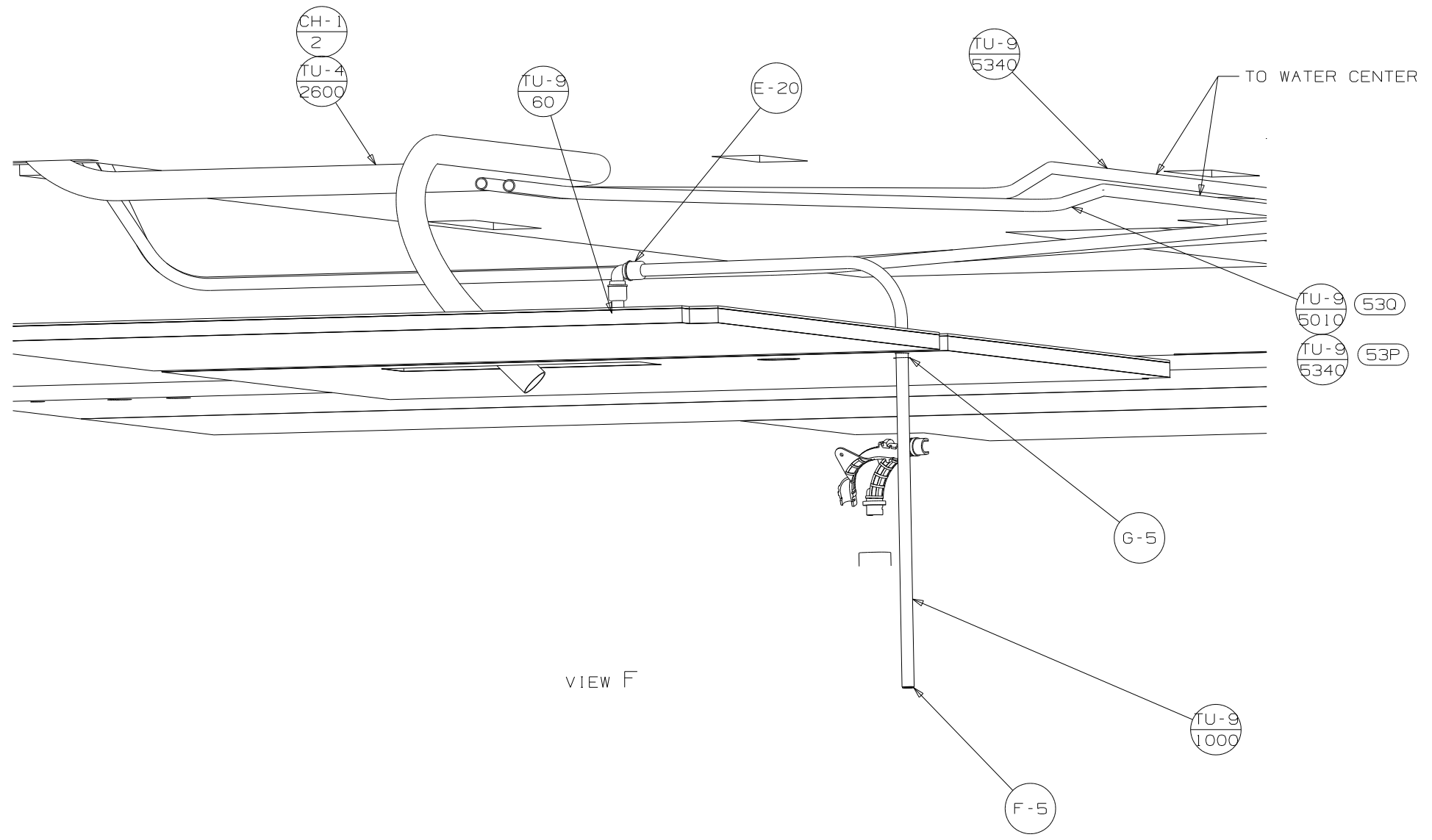

VIEW F

FIRST USED	03 P36GD
TITLE	DO NOT SCALE DRAWING
SHEET 4	PART NO 142743
	1 03/31/03