

- 11 SECURE VENT TUBES TO FLOOR WITH BRACKET 95061-01-000(2) CLAMP 62401-02-000, SCREW G67-10-128(2).
- 10. SECURE PIPES TO CABINET USING WIRE TIE 108046-02-000 AND SCREW G67-10-120(8).
- 9. NOT USED ON CANADIAN UNITS.
- 8. VENT PIPE MUST PROJECT 51 MINIMUM TO 64 MAXIMUM ABOVE ROOF FOR PROPER FIT AND FUNCTION.
- 7. SEE DRAWING 61607-01-000 FOR INSTALLATION OF GROMMET.
- 6. SEAL ALL AROUND SHOWER PAN WITH SILICONE 78474-01-CHT.
- 5. FOR CANADIAN UNITS EACH HOLDING TANK SHALL HAVE A CSA APPROVAL STAMPED NEAR THE IAMPO APPROVAL.
- 4. ALL EXTERIOR OPENINGS AROUND PIPE TO BE SEALED WITH 69637-01-000.
- 3. ALL PIPE AND FITTINGS TO BE ASSEMBLED WITH SOLVENT 4020-01-000.
- 2. SLOPE OF TRAP MUST BE 6 PER 300 MINIMUM.
- 1. SLOPE OF HORIZONTAL PIPING TO BE 6 PER 300 MINIMUM.

SUPPORT ASM-HOLDING TANK
 131297-01-CHT
 SCREW
 G39-08-088(4)

- 21T WASHER/DRYER-WITHOUT
- 54E WASHER/DRYER

FOR DRAINAGE CALLOUTS SEE DWG NO. 116229-01-000

COPYRIGHT 2002 WINNERAGO INDUSTRIES, INC.		02 036C	
OPTR	DATE	UNSPECIFIED TOLERANCES ARE:	MATERIAL:
CHDR	DATE	ANGLE DIM (IN.)	F 8
TRF	DATE	ONE-PLACE (IN.XI)	.
TRF	DATE	TWO-PLACE (IN.XXI)	.
TRF	DATE	ANGLE	.
CDR	DATE	THIRD ANGLE PROJECTION	☺
DRW	DATE		
LANHT 036C	TITLE:	DRAINAGE SYSTEM INSTL	
DRW	SCALE: NONE	30 MM SCALE DRAWING	FIG NO 137722
ALL DIMENSIONS ARE IN MILLIMETERS	SHEET 1 OF 3	1 E	

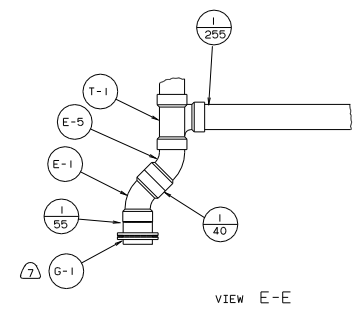
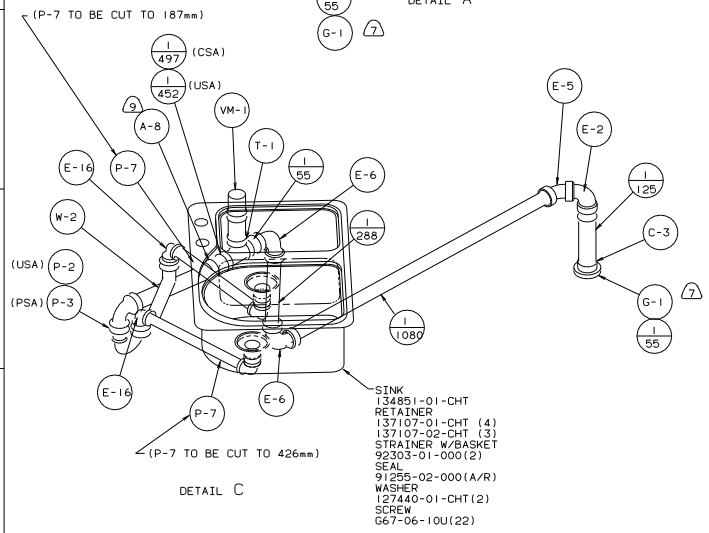
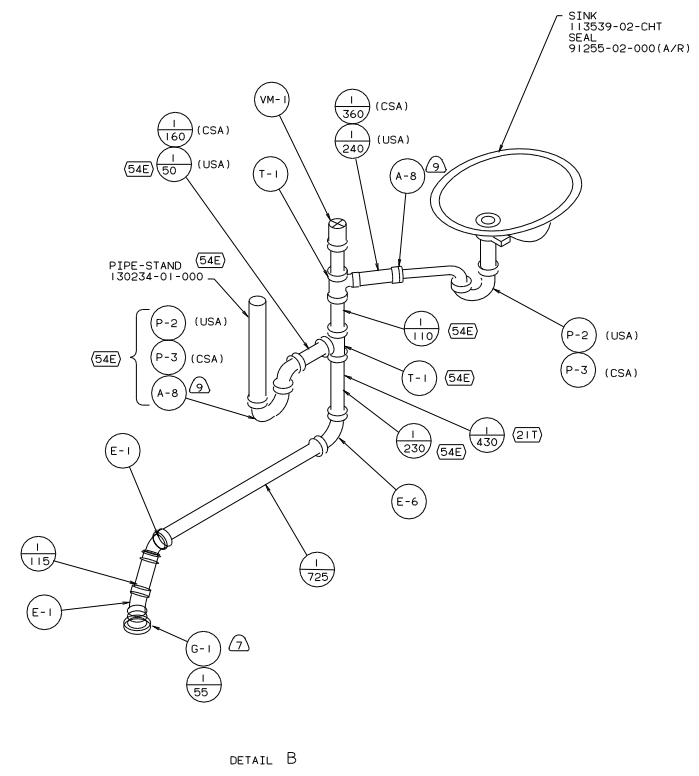
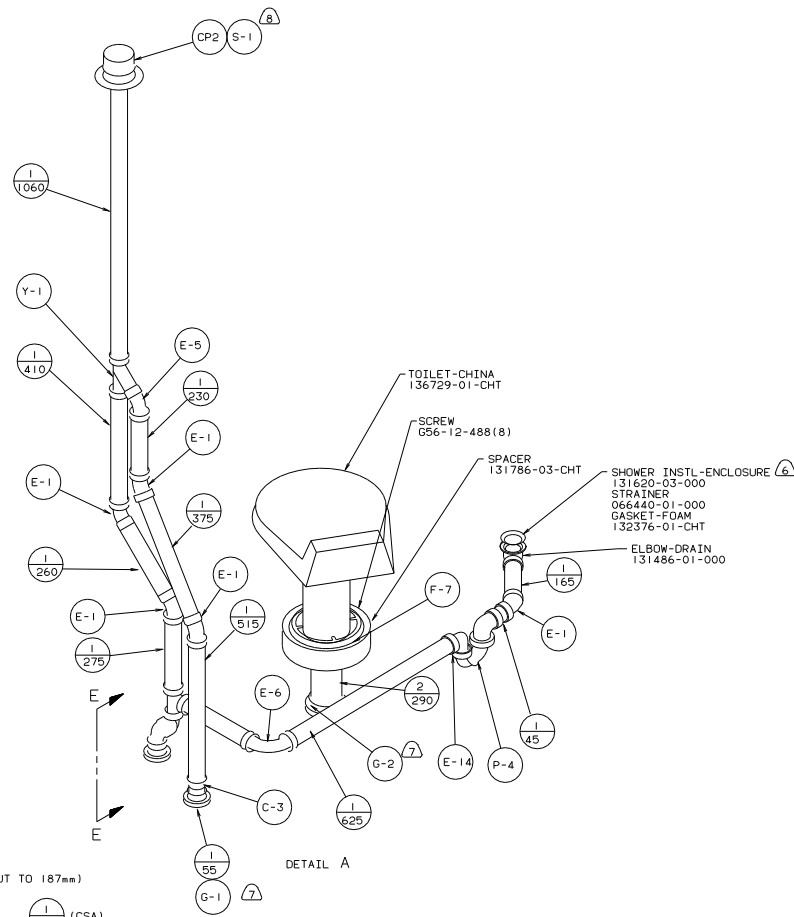

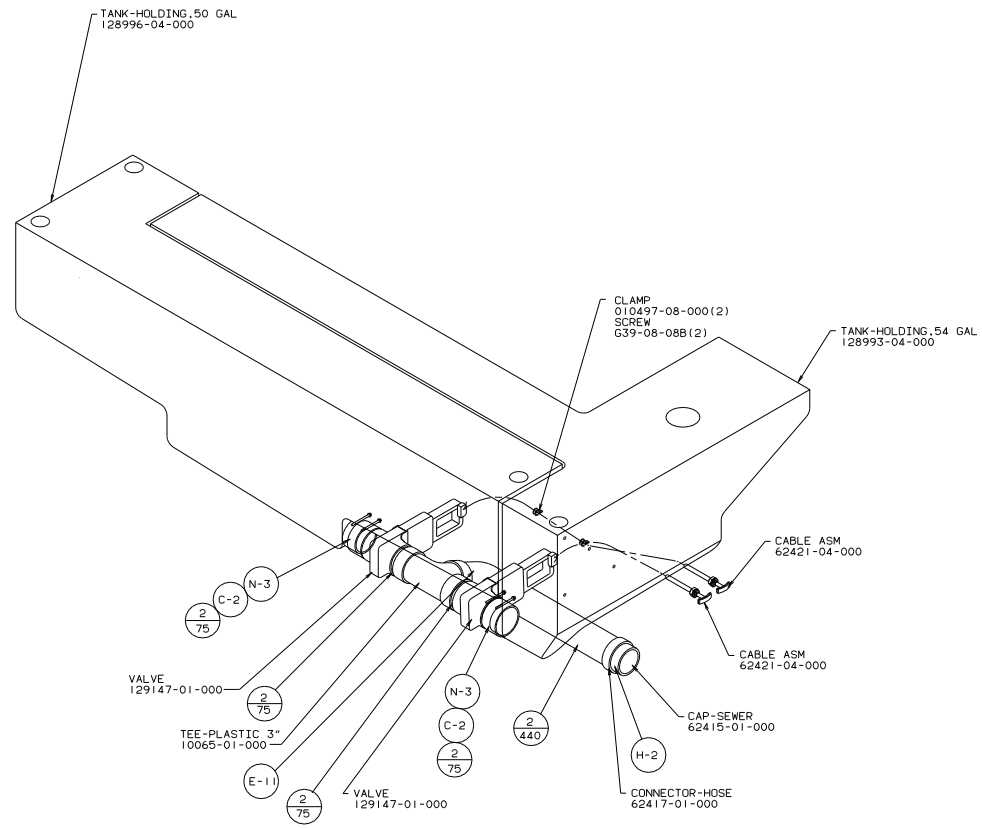

DETAIL D

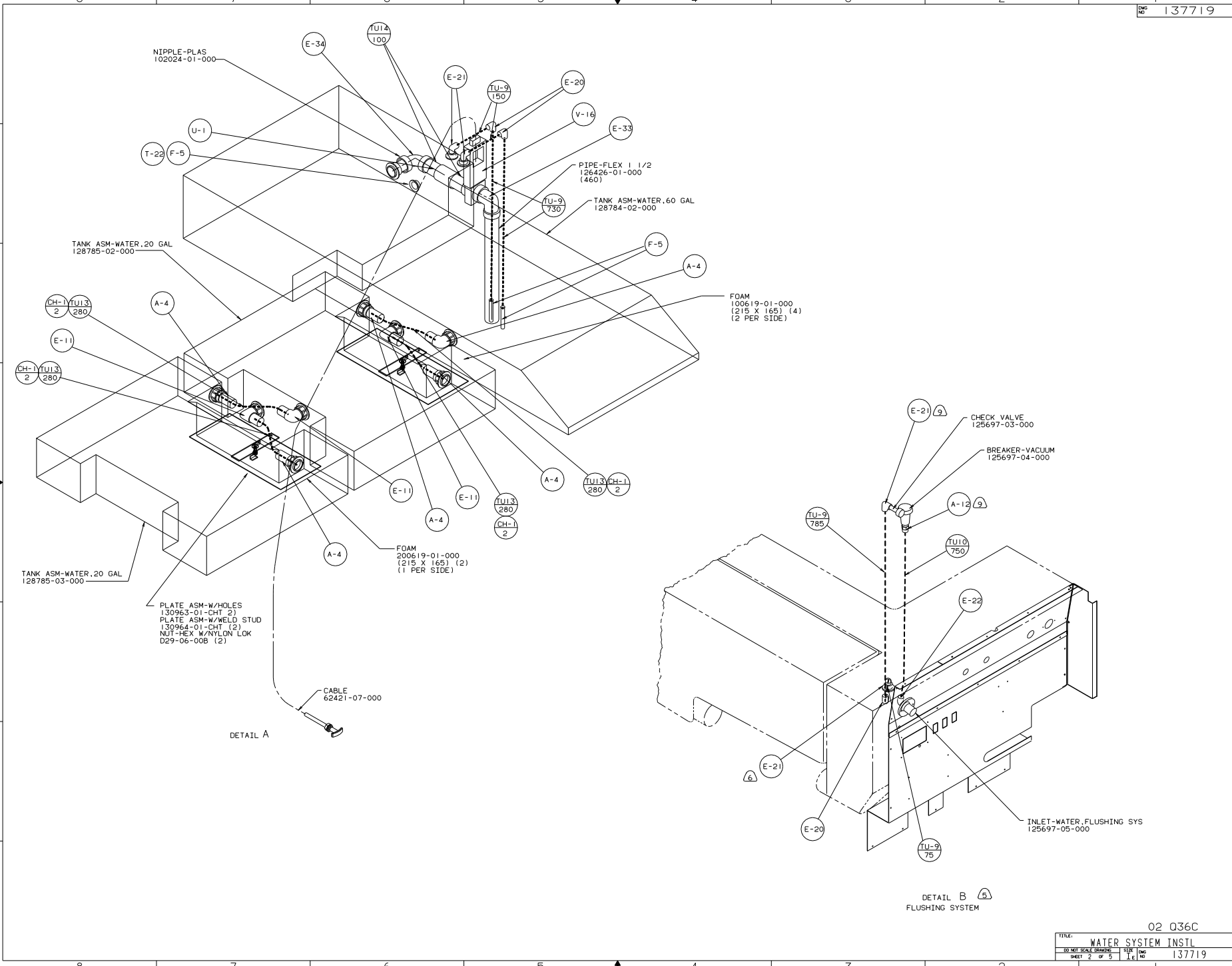

DETAIL A

DETAIL B (5)

FLUSHING SYSTEM

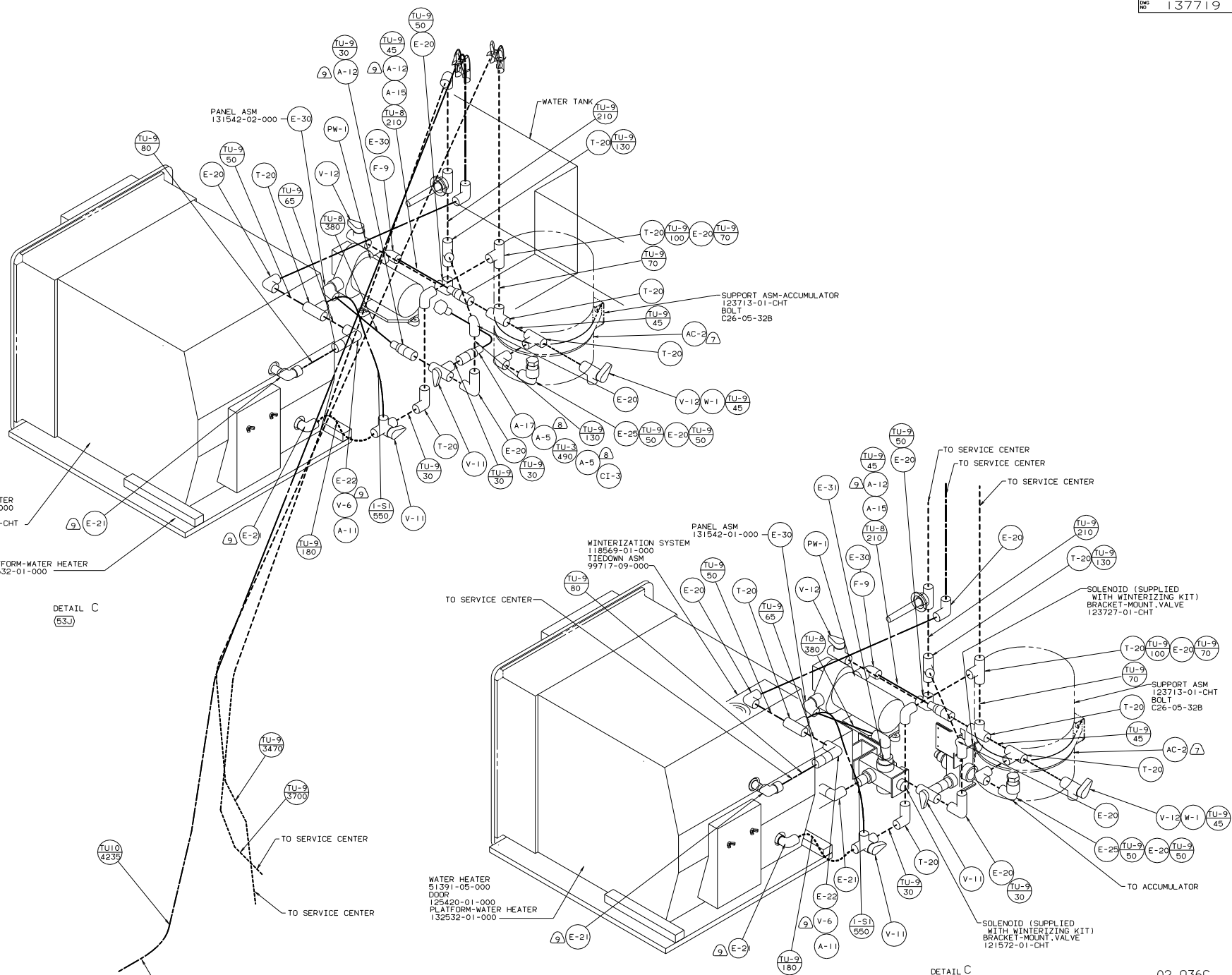

DETAIL C (53J)

DETAIL C (530)

02 036C

TITLE		WATER SYSTEM INSTL	
30 NET SCALE DRAWING	SIZE	1/8	1/4
SHEET 3	OF 5	1	1
		137719	

