



**DANGER**

**Danger of electrical shock, burns or death.** Always remove all power sources before attempting any repair, service or diagnostic work. Power can be present from shore power, generator, inverter or battery. All power sources must be disabled and secured before performing any service.



**CAUTION**

If you lack the skills, tools or equipment to perform diagnostic or repair work leave such work to an authorized Winnebago Industries dealer or other qualified shop.



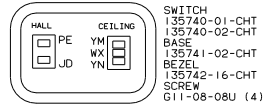

DETAIL BC

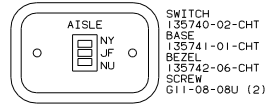

DETAIL BA

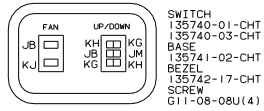

DETAIL BB

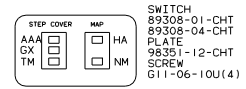

DETAIL BR

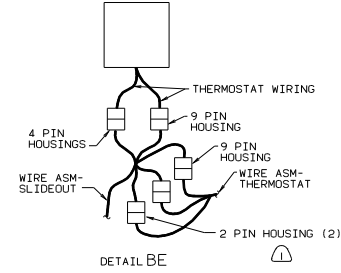
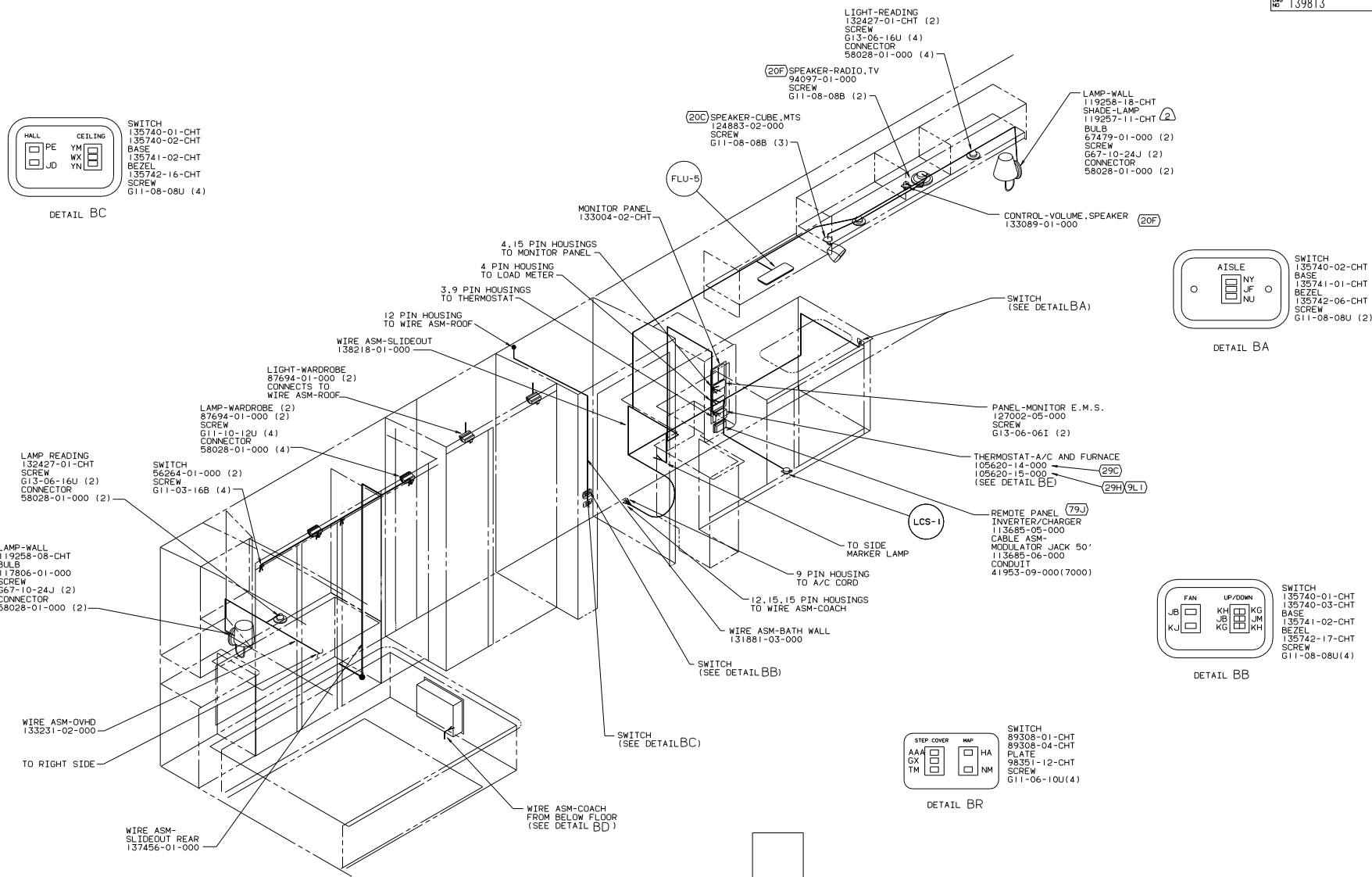

DETAIL BE

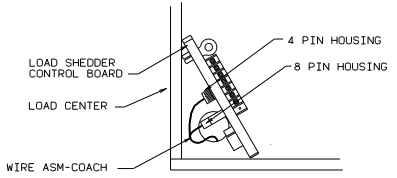

DETAIL BD

2 SEE STYLING SHEET FOR ADDITIONAL INFORMATION.

1 WITHOUT (29H) PLUG THE TWO, TWO PIN HOUSINGS TOGETHER ON WIRE ASM-SLIDEOUT.

NOTES:

FOR ELECTRICAL TORQUE SPECIFICATIONS SEE DWG NO. 128783-01-000

FOR ELECTRICAL CALLOUTS SEE DWG NO. 121339-01-000

- (9L1) HOME COMFORT PLUS PACKAGE
- (29H) HEAT PUMP-A/C CENTRAL
- (29C) A/C CENTRAL
- (79J) INVERTER/CHARGER-1.500 WATT
- (715) VENT-POWER
- (265) CODES/STANDARDS-CSA/CMVSS
- (20C) SOUND SYS. DLX. W/O-SURROUND
- (20F) DELUXE SOUND SYSTEM-WITHOUT
- (1B1) CODES/STANDARDS USA

02 P36L (1B1)(265)

TITLE: WIRING INSTL-BODY 12V(L)

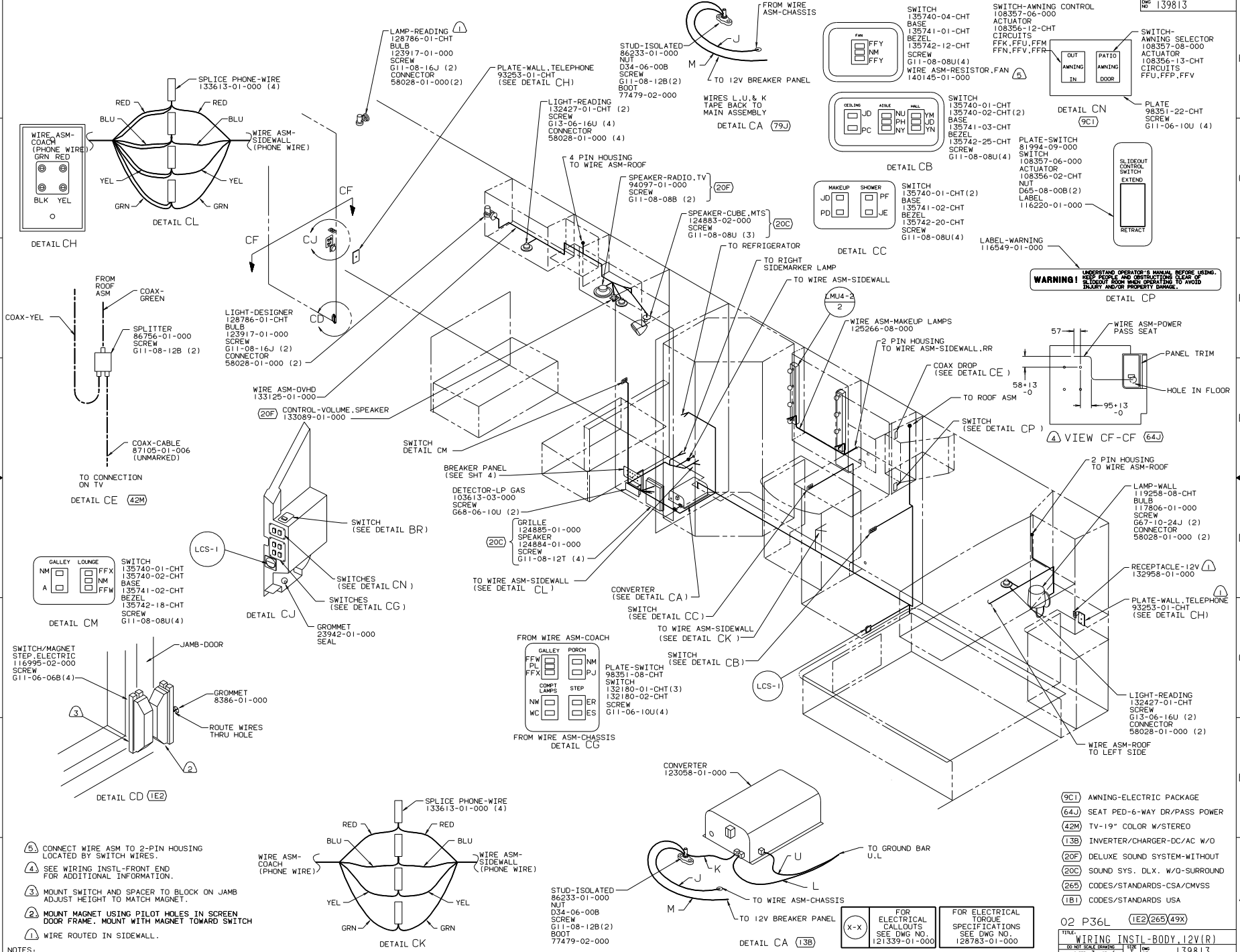

**WARNING!**  
 UNDERSTAND OPERATOR'S MANUAL BEFORE LEAVING PEOPLE AND OBSTRUCTIONS CLEAR OF SLIDING ROOM SEAT OPERATING TO AVOID INJURY AND/OR PROPERTY DAMAGE.

- 1. WIRE ROUTED IN SIDEWALL.
- 2. MOUNT MAGNET USING PILOT HOLES IN SCREEN DOOR FRAME. MOUNT WITH MAGNET TOWARD SWITCH
- 3. MOUNT SWITCH AND SPACER TO BLOCK ON JAMB ADJUST HEIGHT TO MATCH MAGNET.
- 4. SEE WIRING INSTL-FRONT END FOR ADDITIONAL INFORMATION.
- 5. CONNECT WIRE ASM TO 2-PIN HOUSING LOCATED BY SWITCH WIRES.

- (9C1) AWNING-ELECTRIC PACKAGE
- (64J) SEAT PED-6-WAY DR/PASS POWER
- (42M) TV-19" COLOR W/STEREO
- (13B) INVERTER/CHARGER-DC/AC W/O
- (20F) DELUXE SOUND SYSTEM-WITHOUT
- (20C) SOUND SYS. DLX. W/O-SURROUND
- (26S) CODES/STANDARDS-CSA/CMVSS
- (1B1) CODES/STANDARDS USA

(X-X) FOR ELECTRICAL CALLOUTS SEE DWG NO. 121339-01-000

FOR ELECTRICAL TORQUE SPECIFICATIONS SEE DWG NO. 128783-01-000

02 P36L (1E2)(26S)(49X)  
 TITLE WIRING INSTL-BODY 12V(R)  
 SHEET 3 OF 6 I.e. No 139813

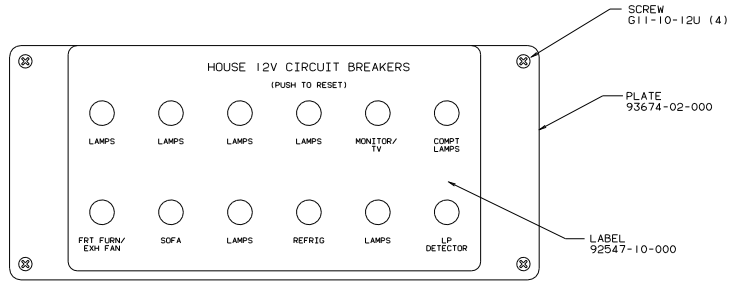

CIRCUIT BREAKER (FRONT VIEW)

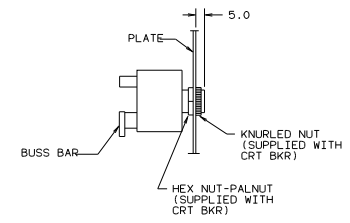

SECTION DA-DA

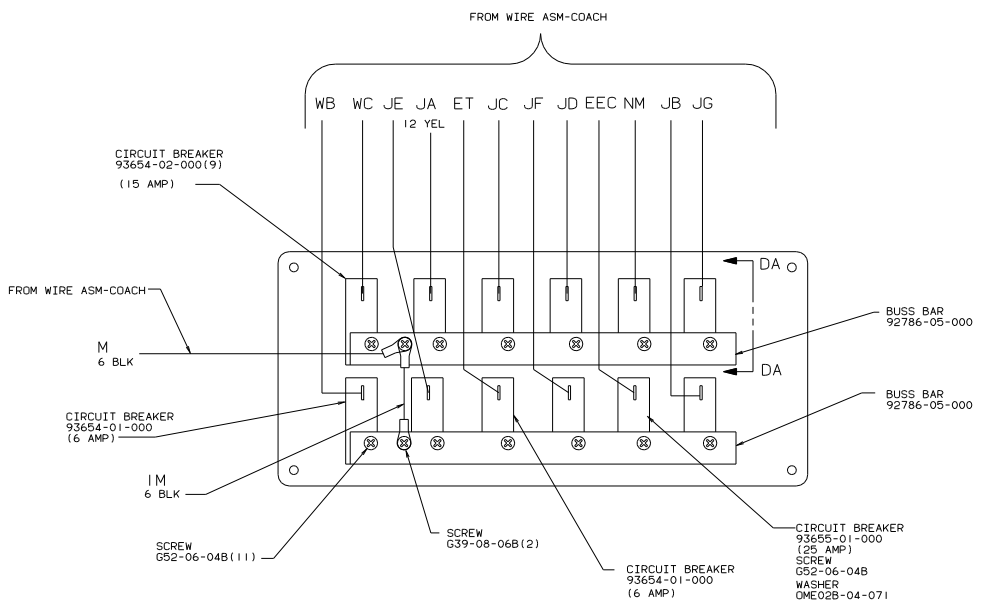

CIRCUIT BREAKER (BACK VIEW)

NOTE: CONNECT BLUE WIRES FROM RESET TO THE BLUE WIRE WITH SPADE TERMINALS ON A/C CORD WITH 29H 9L1 FEATURE.

(265) CODES/STANDARDS-CSA/CMVSS  
(1B1) CODES/STANDARDS USA

FOR ELECTRICAL TORQUE SPECIFICATIONS SEE DWG NO. 128783-01-000

02 P36L (1B1)(265)  
TITLE: WIRING INSTL-BODY,12V(BP)  
DO NOT SCALE DRAWING SHEET 4 OF 6 I.F. NO 139813

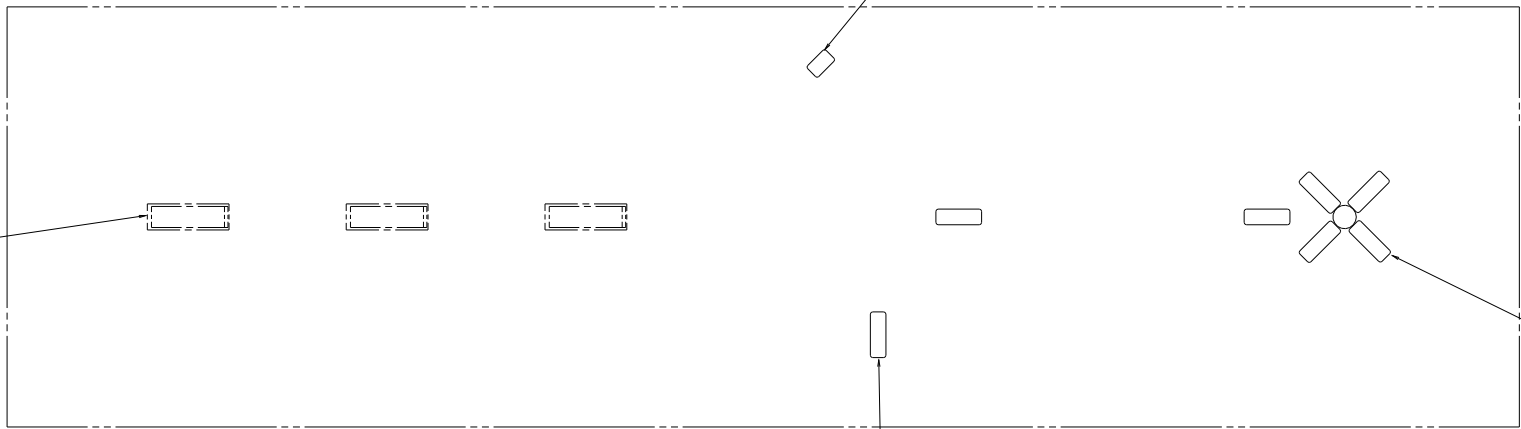

CEILING FAN  
159134-01-CHT  
SCREW  
G11-10-16B (3)  
CONNECTOR  
58028-01-000(2)

48V  
FLUNA  
3

SWITCH-PUSH BUTTON  
41250-01-000 (5)  
BRACKET-SWITCH, LIGHT  
138494-01-CHT (5)  
SCREW  
G39-08-16E (20)  
WASHER-PLASTIC  
87080-02-CHT (5)  
SCREW  
G11-08-08B (10)

48M  
LFSN1  
3

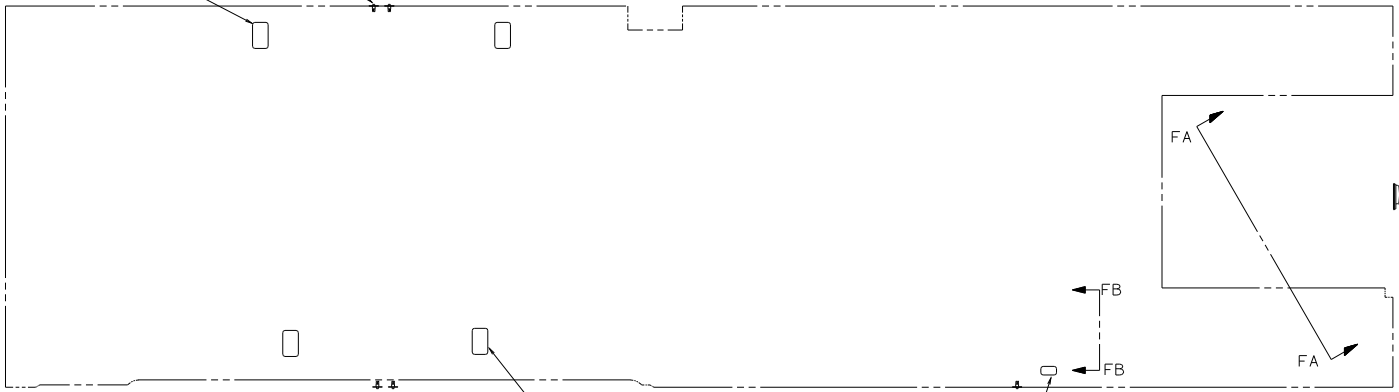

LF1-2

LF1-2

LEFT FRONT COMPARTMENT

LF1N2  
4

WASHER-PLASTIC  
87080-02-CHT (4)  
SCREW  
G11-08-08B (8)

LAMP  
86280-01-000  
SCREW  
G67-10-12U (2)  
CONNECTOR  
58028-01-000 (2)  
WASHER-PLASTIC  
87080-02-CHT  
SCREW  
G11-08-08B (2)

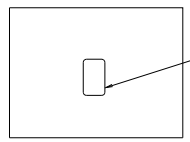

VIEW FB-FB

LF1N2

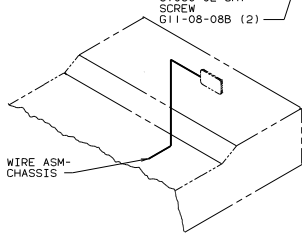

VIEW FA-FA

- (48V) LIGHTS-FLUORESCENT
- (48M) LIGHTS-INCANDESCENT
- (265) CODES/STANDARDS-CSA/CMVSS
- (1B1) CODES/STANDARDS USA

FOR ELECTRICAL TORQUE SPECIFICATIONS SEE DWG NO. 128783-01-000

FOR ELECTRICAL CALLOUTS SEE DWG NO. 121339-01-000

02 P36L (1B1) (265)  
WIRING INSTL-BODY, 12V (LAMPS)  
DWG SCALE: none TITLE NO 139813  
SHEET 5 OF 6 I.F. NO

NOTES:  
② LAMPS LOCATED IN SLIDEOUT COMPARTMENTS.  
⚠ LAMPS TO BE MOUNTED WITH SWITCH OUTBOARD AND 75 ±20 FROM EDGE OF FLOOR.

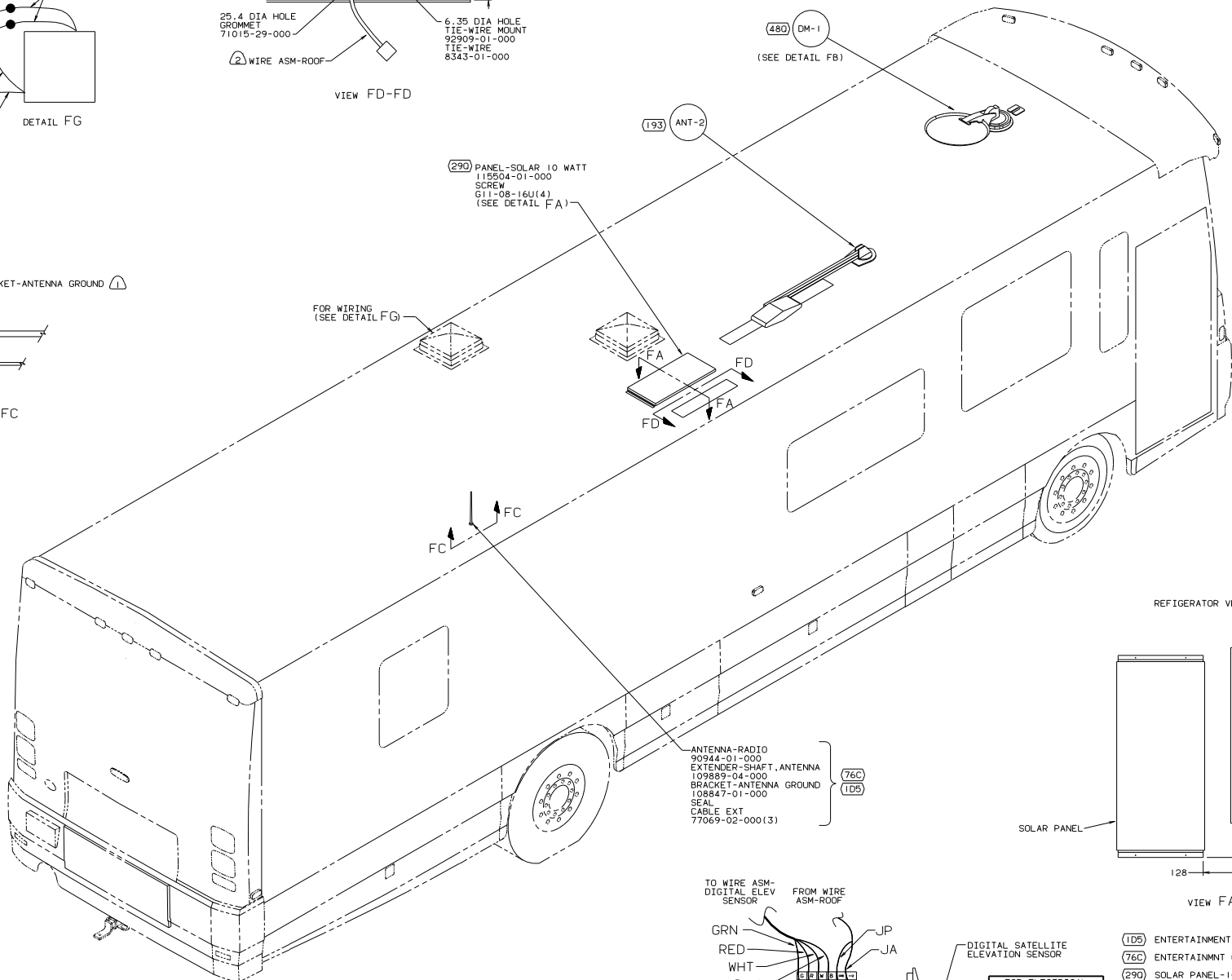
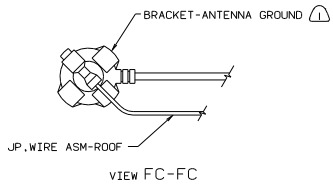
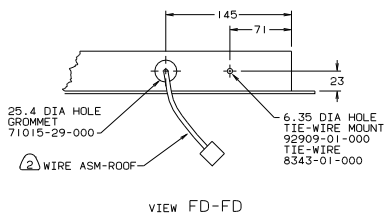
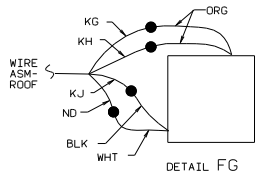

- ANTENNA-RADIO 90944-01-000
  - EXTENDER-SHAFT, ANTENNA 109889-04-000
  - BRACKET-ANTENNA GROUND 108847-01-000
  - SEAL CABLE EXT 77069-02-000(3)
- (76C)  
(1D5)

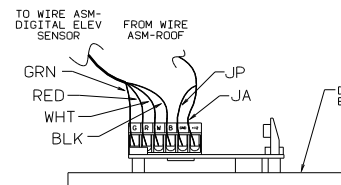
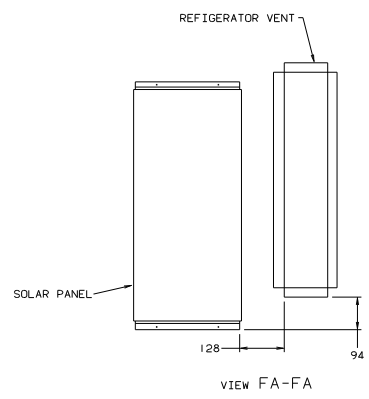

- (1D5) ENTERTAINMENT CENTR/EXT W/CD
- (76C) ENTERTAINMENT CTR/EXT CASSETTE
- (290) SOLAR PANEL-10 WATT
- (265) CODES/STANDARDS-CSA/CMVSS
- (1B1) CODES/STANDARDS USA

FOR ELECTRICAL TORQUE SPECIFICATIONS SEE DWG NO 128783-01-000

FOR ELECTRICAL CALLOUTS SEE DWG NO 121339-01-000

X-X

02 P36L (1B1)(265)

WIRING INSTL-BODY, 12V(EXT)

DO NOT SCALE DRAWING

SHEET 6 OF 6

- NOTES:
- (2) FASTEN TO VENT.
  - (1) WRAP BRACKET LEGS AROUND ANTENNA BASE.

DETAIL FB (480)