

- NOTES:
1. SLOPE OF HORIZONTAL PIPING TO BE 6 PER 305 MM.
 2. SLOPE OF TRAP ARM MUST BE 6 PER 305 MM.
 3. ALL PIPE AND FITTINGS TO BE ASSEMBLED WITH SOLVENT 4020-01-000.
 4. ALL EXTERIOR OPENINGS AROUND PIPE TO BE SEALED WITH 110744-01-000.
 5. SEAL AROUND SHOWER WITH SILICONE.
 6. TRIM P-TRAP EXTENSION TO FIT.
 7. FASTEN TO BOTTOM OF UPPER FLOOR.
 8. VENT PIPE MUST PROJECT 51 MIN AND 63.5 MAX ABOVE ROOF FOR PROPER FIT AND FUNCTION.
 9. SECURE PIPES TO CABINET USING WIRE TIE 108046-02-000 AND SCREW G67-10-12B.
 10. SEE DRAWING 61607-01-000 FOR INSTL OF GROMMETS.
 11. TOLIET TO BE TURNED 45° FROM SIDEWALL.

- (54E) WASHER/DRYER
- (21M) WASHER/DRYER PREP
- (43E) TOILET PORCELAIN-ROUND
- (265) CODES/STDS-CSA/CMVSS
- (1B1) CODES/STANDARDS-USA

WINNEBAGO		COPYRIGHT 2002 WINNEBAGO INDUSTRIES, INC.	
DFT	ORIG. DATE	ALL DIMENSIONS ARE IN MILLIMETERS	
CHKR		MATERIAL:	
P.E.		UNSPECIFIED TOLERANCES ARE:	
M.E.		WHOLE DIM (X)	: 7
DSNR		ONE-PLACE (X.X)	:
		TWO-PLACE (X.XX)	:
		ANGLE	:
		THIRD ANGLE PROJECTION	
DO NOT SCALE DRAWING			
TITLE: DRAINAGE SYSTEM INSTL			
SHEET 1 OF 3	PART NO	138508	
REF: 135476 1			

FOR
DRAINAGE
CALLOUTS
SEE DWG NO
116229-01-000

DETAIL D

SINK-SMC, DBL
136828-01-CHT (US/CAN)
STRAINER
92303-01-000 (2)
SEAL
91255-02-000 (A/R)
ANGLE-FORMED
140002-01-CHT (10)
SCREW
G67-10-08B (8)
WASHER-RUBBER
127440-02-CHT (2)

SINK
142285-01-CHT
TAILPIECE
106116-01-CHT
GASKET
106116-02-CHT
ANGLE
131914-06-CHT (4)
SCREW
G67-08-10U (6)

TOILET
134789-01-CHT
SCREW
G57-14-64B (8)

SHOWER INSTL
131620-01-000
STRAINER
066440-01-000
GASKET
132376-01-CHT
ELBOW-DRAIN
131486-01-000

CONT. WASTE
91980-01-000

PIPE-STAND
130234-01-000

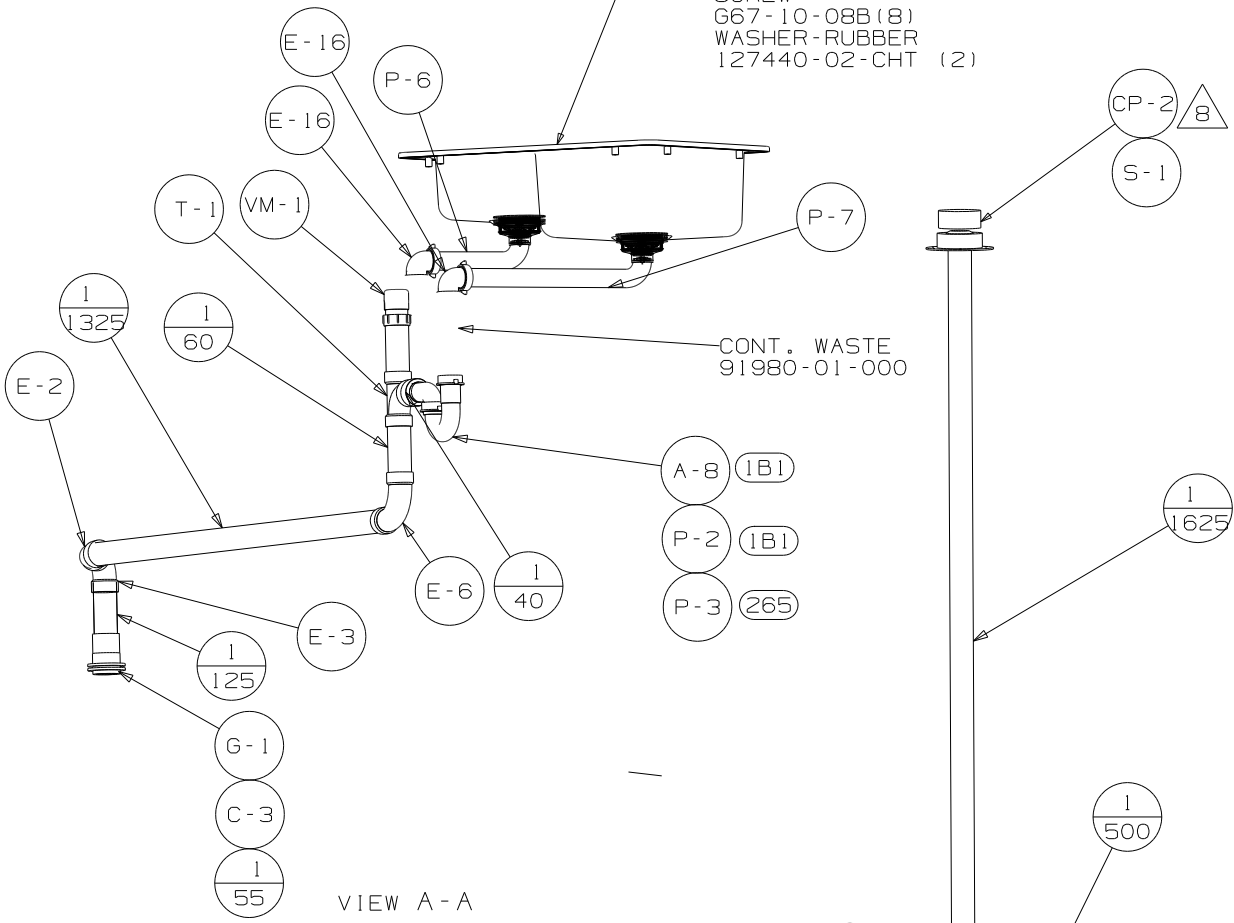

VIEW A-A

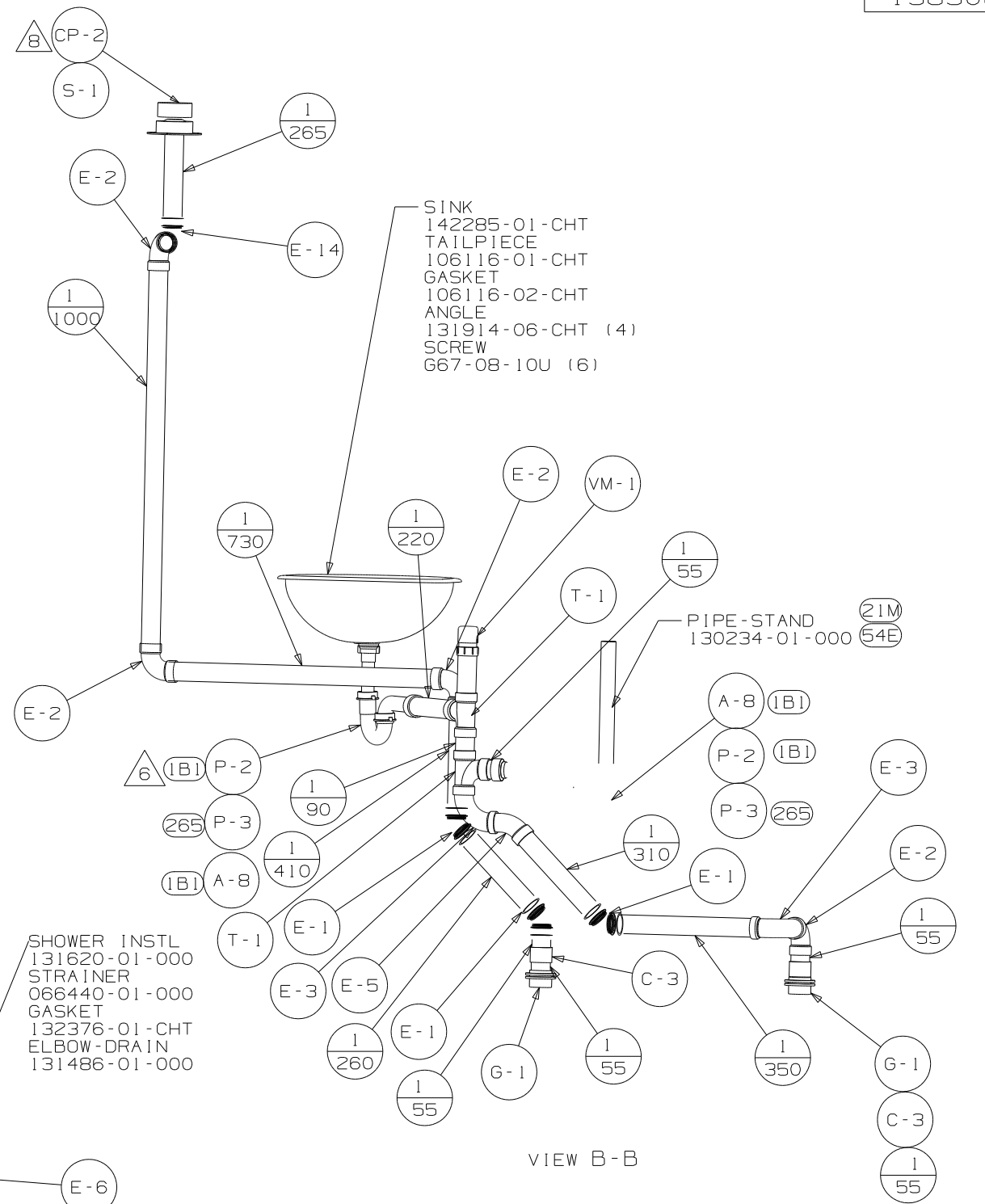

VIEW B-B

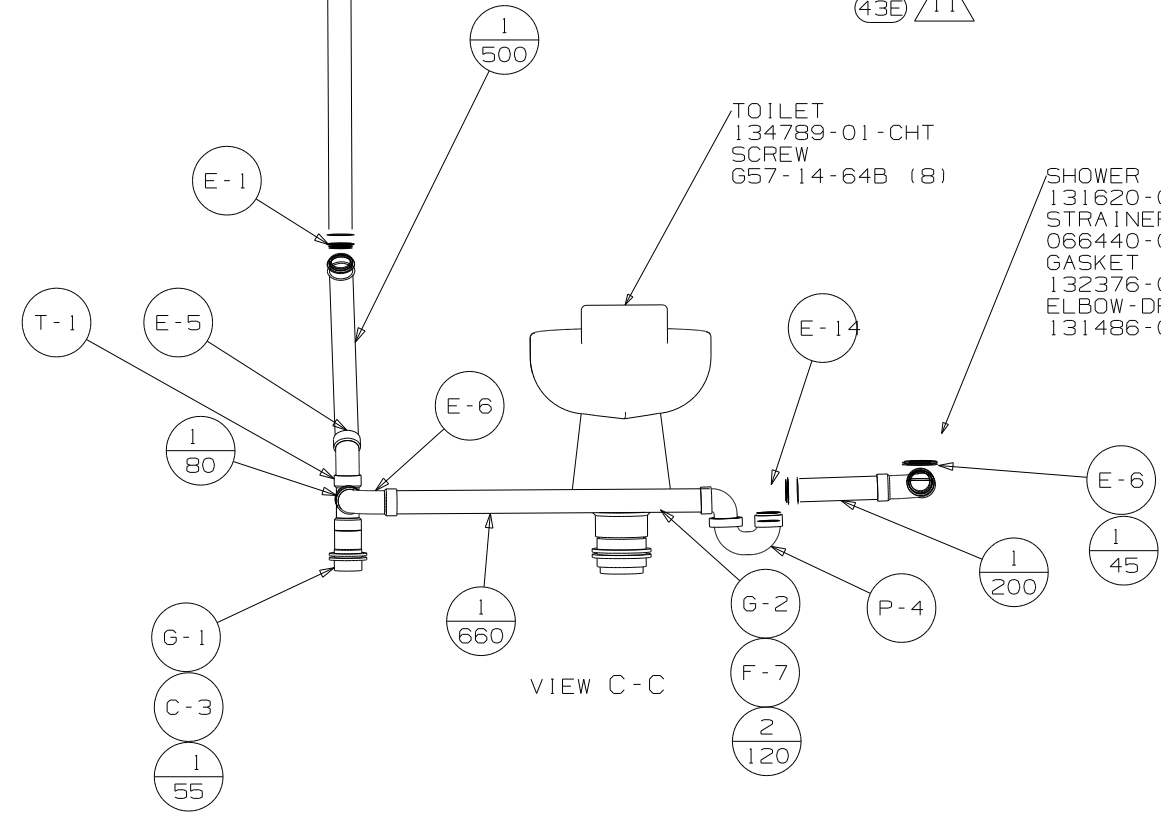

VIEW C-C

FIRST USED	02 P36C
TITLE	DO NOT SCALE DRAWING
TITLE	DRAINAGE SYSTEM INSTL
SHEET 2	PART NO 138508

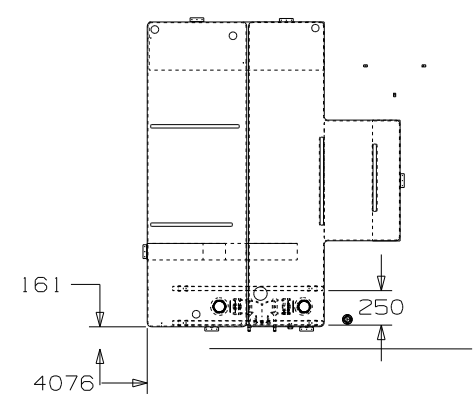
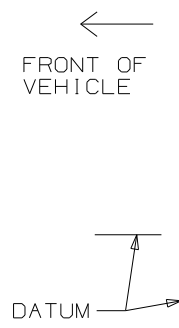
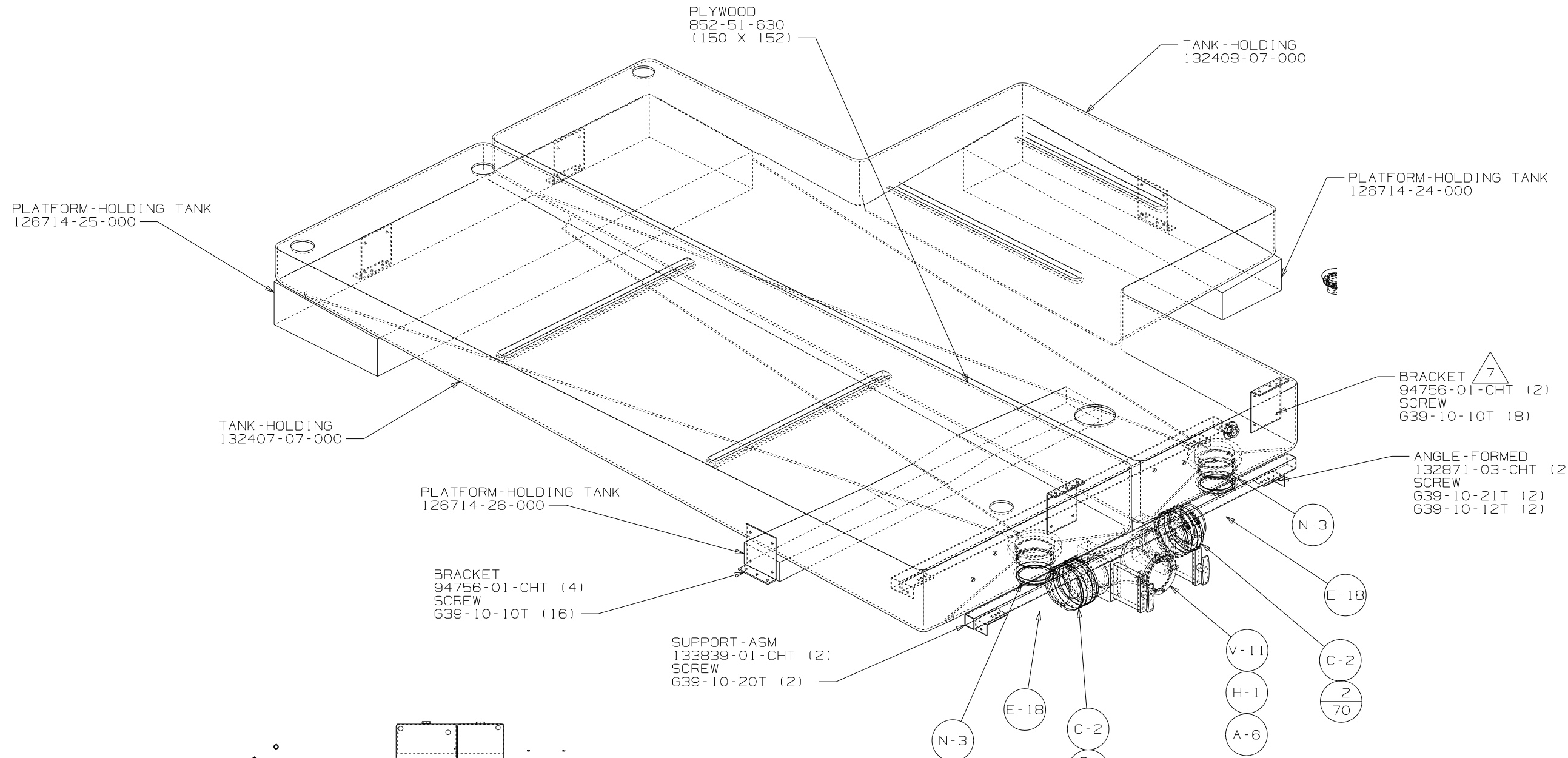

DETAIL D

FIRST USED	02 P36C
DO NOT SCALE DRAWING	
TITLE	DRAINAGE SYSTEM INSTL
SHEET 3	PART NO 138508

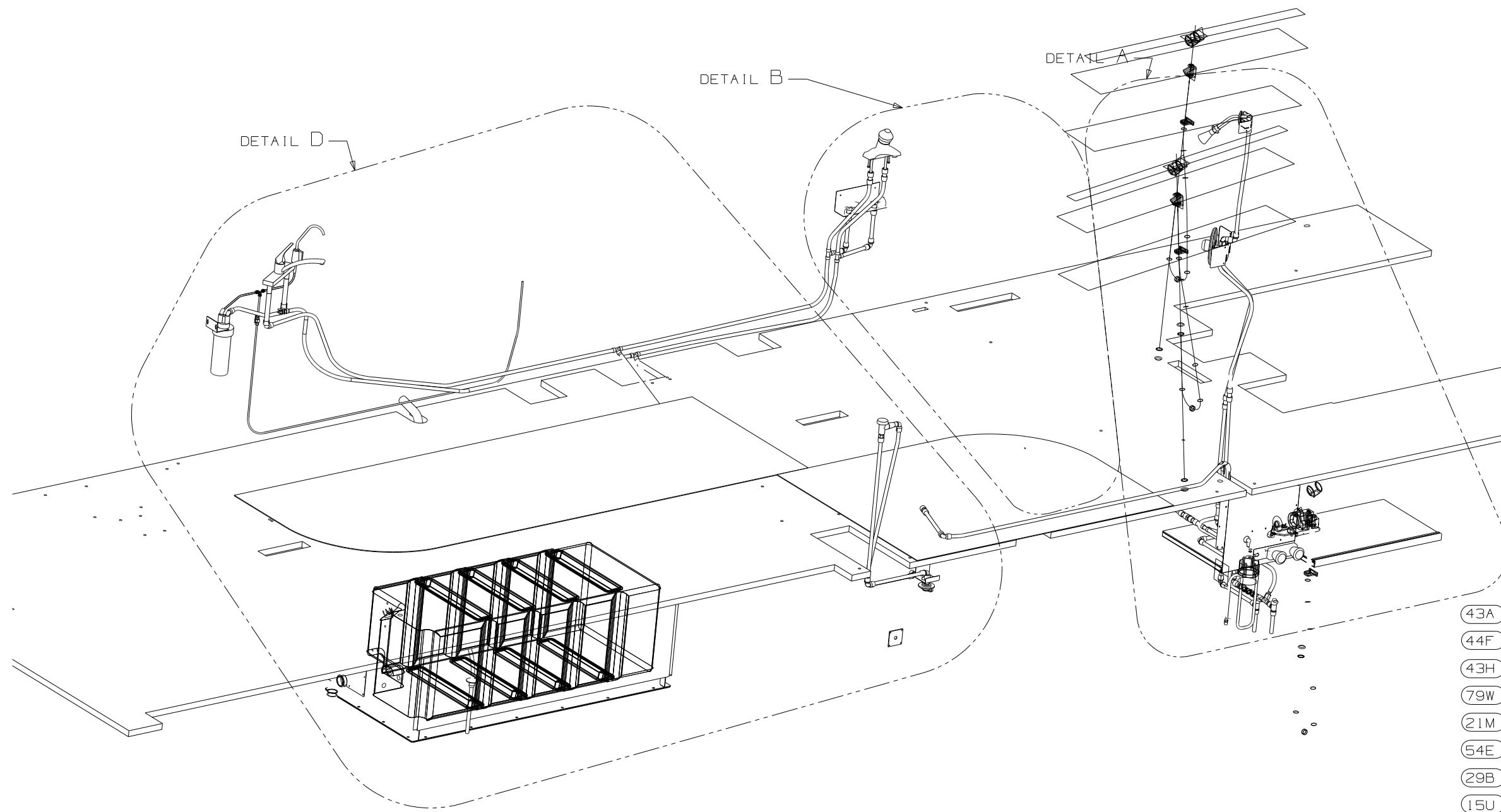

- (43A) SHOWER HEAD FIXED
- (44F) BATH COUNTERTOP SOLID SURFACE
- (43H) SHOWER HEAD-HAND HELD
- (79W) 4-DOOR REFRIG
- (21M) WASHER/DRYER PREP
- (54E) WASHER DRYER
- (29B) WATER PURIFIER
- (15U) REFRIGERATOR/FRZR W/ICEMAKER

- NOTES:
1. PLASTIC FITTINGS TO BE SEALED WITH SEALANT 84456-01-000
 2. TUBING TO BE INSTALLED WITH SUFFICIENT SLOPE TO PROVIDE DRAINAGE TO NEAREST VALVE.
 3. ALL TUBING TO BE SECURED AT 1200 INTERVALS MAXIMUM WITH CLAMP 10495-01-000 OR CLIP 9151-01-000 AND SCREW G67-10-12B.
 4. FLUSHING SYSTEM REQUIRES 125697-06-000 INSTRUCTION SHEET.
 5. ADD TEFLON TAPE 10405-02-000 TO FITTING.
 6. ADD TEFLON TAPE 10405-03-000 TO FITTING.
 7. ADD TEFLON TAPE 10405-01-000 TO FITTING.
 8. APPLY DECAL INSIDE OF UPPER SHOWER HEAD HOLDER TO RETAIN HAND SHOWER UNIT INSIDE OF HOLDER.

WINNEBAGO		COPYRIGHT 2002 WINNEBAGO INDUSTRIES, INC.	
DFTR	ORIG. DATE	ALL DIMENSIONS ARE IN MILLIMETERS	
CHKR		FIRST USED	
P.E.		02 P36C	
M.E.		UNSPECIFIED TOLERANCES ARE:	
DSNR		MATERIAL:	
		WHOLE DIM (X)	: 7
		ONE-PLACE (X.X)	:
		TWO-PLACE (X.XX)	:
		ANGLE	:
THIRD ANGLE PROJECTION		DO NOT SCALE DRAWING	
TITLE: WATER SYSTEM INSTL			
SHEET 1 OF 4		PART NO 138507	

X-X
FOR
WATER
CALLOUTS
SEE DWG NO.
116230-01-000

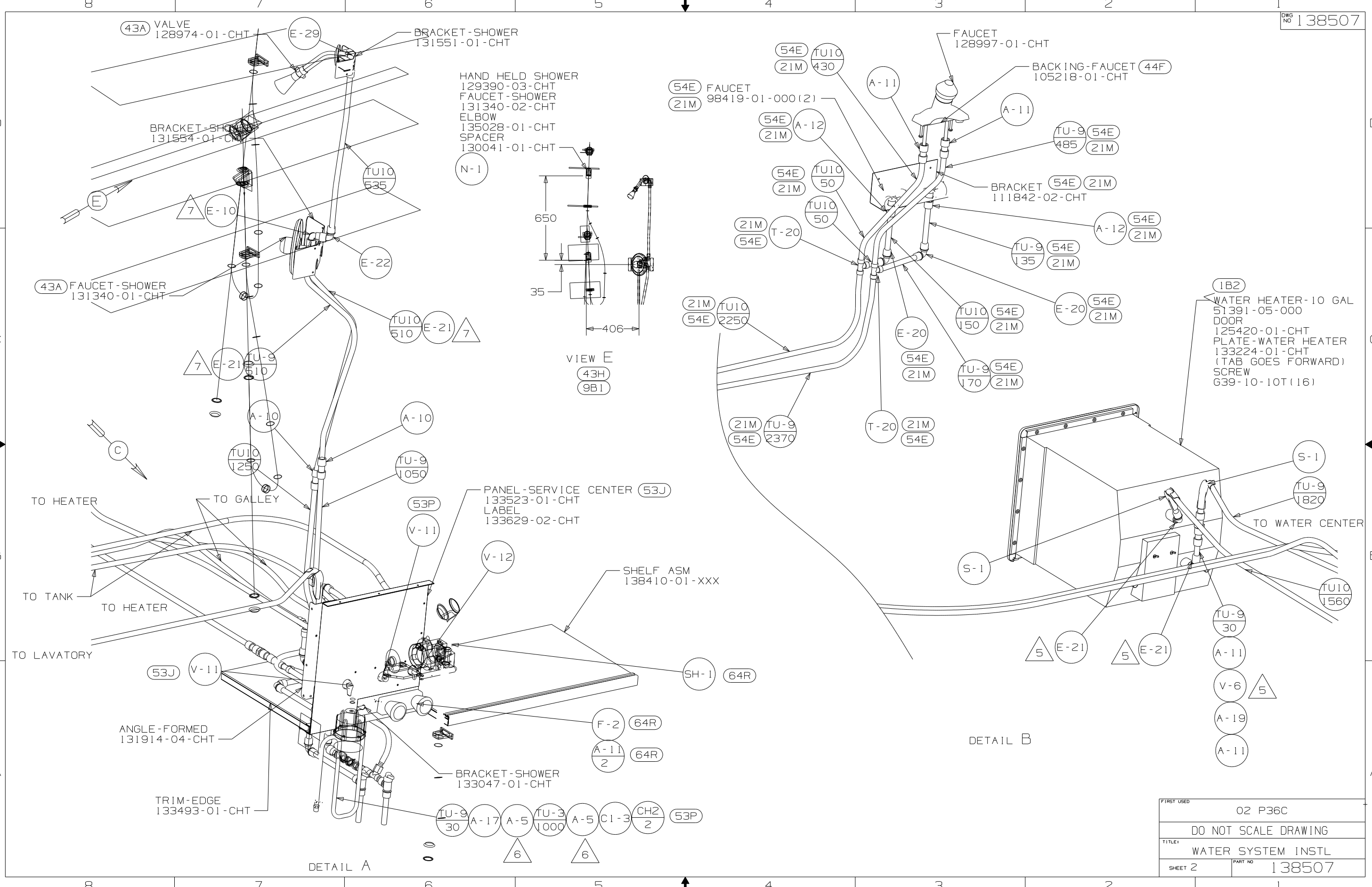

HAND HELD SHOWER
 129390-03-CHT
 FAUCET-SHOWER
 131340-02-CHT
 ELBOW
 135028-01-CHT
 SPACER
 130041-01-CHT

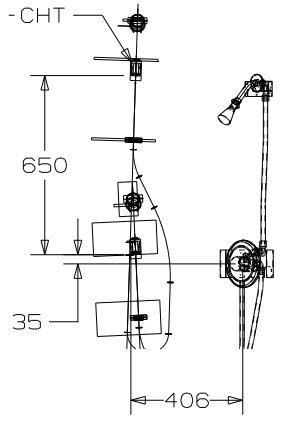

VIEW E
 43H
 9B1

WATER HEATER-10 GAL
 51391-05-000
 DOOR
 125420-01-CHT
 PLATE-WATER HEATER
 133224-01-CHT
 (TAB GOES FORWARD)
 SCREW
 639-10-10T(16)

FIRST USED	02 P36C
TITLE	DO NOT SCALE DRAWING
	WATER SYSTEM INSTL
SHEET 2	PART NO 138507

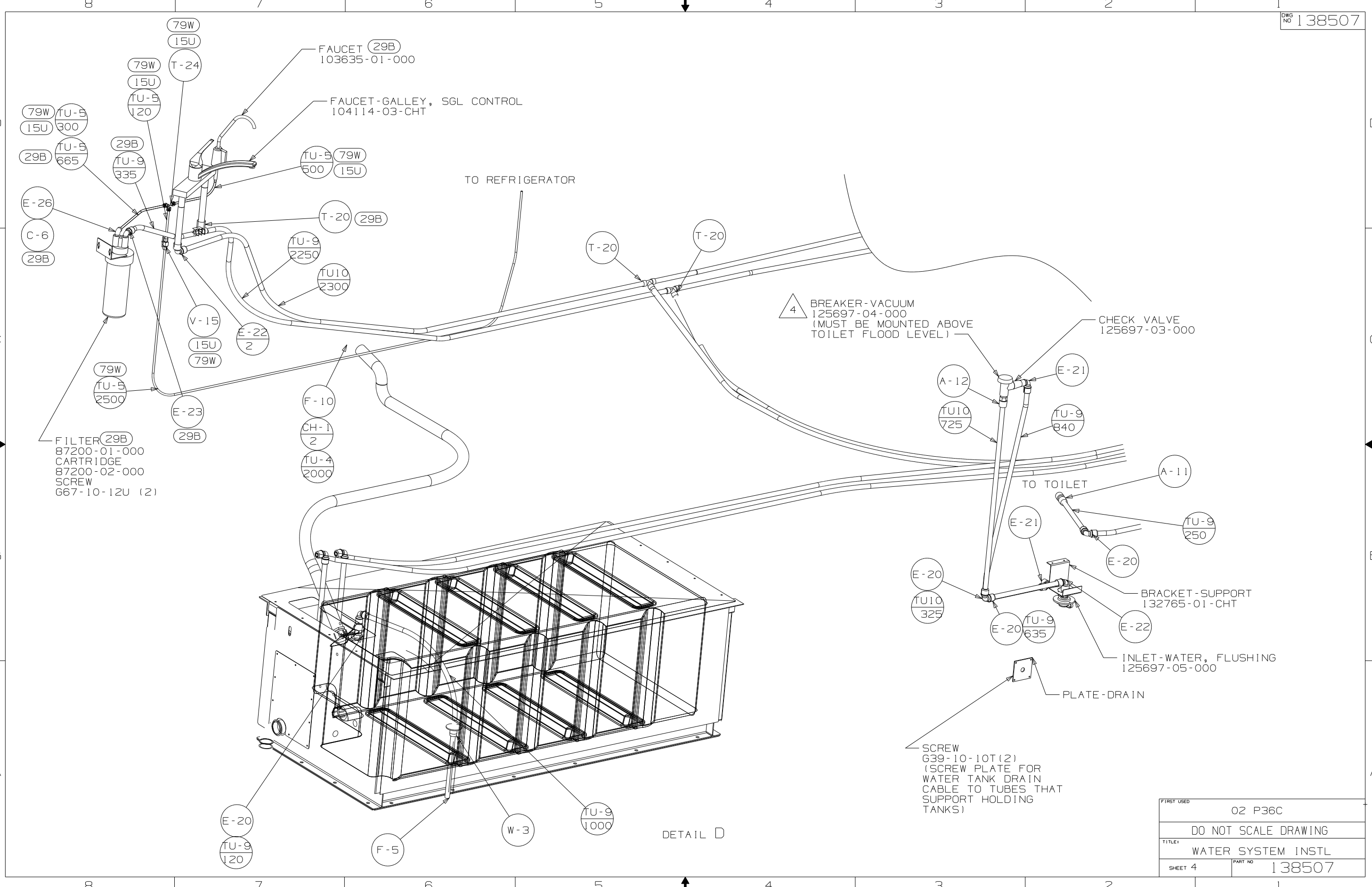

FAUCET (29B)
103635-01-000

FAUCET-GALLEY, SGL CONTROL
104114-03-CHT

TO REFRIGERATOR

4 BREAKER-VACUUM
125697-04-000
(MUST BE MOUNTED ABOVE
TOILET FLOOD LEVEL)

CHECK VALVE
125697-03-000

FILTER (29B)
87200-01-000
CARTRIDGE
87200-02-000
SCREW
667-10-12U (2)

TO TOILET

BRACKET-SUPPORT
132765-01-CHT

INLET-WATER, FLUSHING
125697-05-000

PLATE-DRAIN

SCREW
G39-10-10T(2)
(SCREW PLATE FOR
WATER TANK DRAIN
CABLE TO TUBES THAT
SUPPORT HOLDING
TANKS)

DETAIL D

FIRST USED	02 P36C
TITLE	DO NOT SCALE DRAWING
SHEET 4	PART NO 138507