



DANGER

Danger of electrical shock, burns or death. Always remove all power sources before attempting any repair, service or diagnostic work. Power can be present from shore power, generator, inverter or battery. All power sources must be disabled and secured before performing any service.



CAUTION

If you lack the skills, tools or equipment to perform diagnostic or repair work leave such work to an authorized Winnebago Industries dealer or other qualified shop.

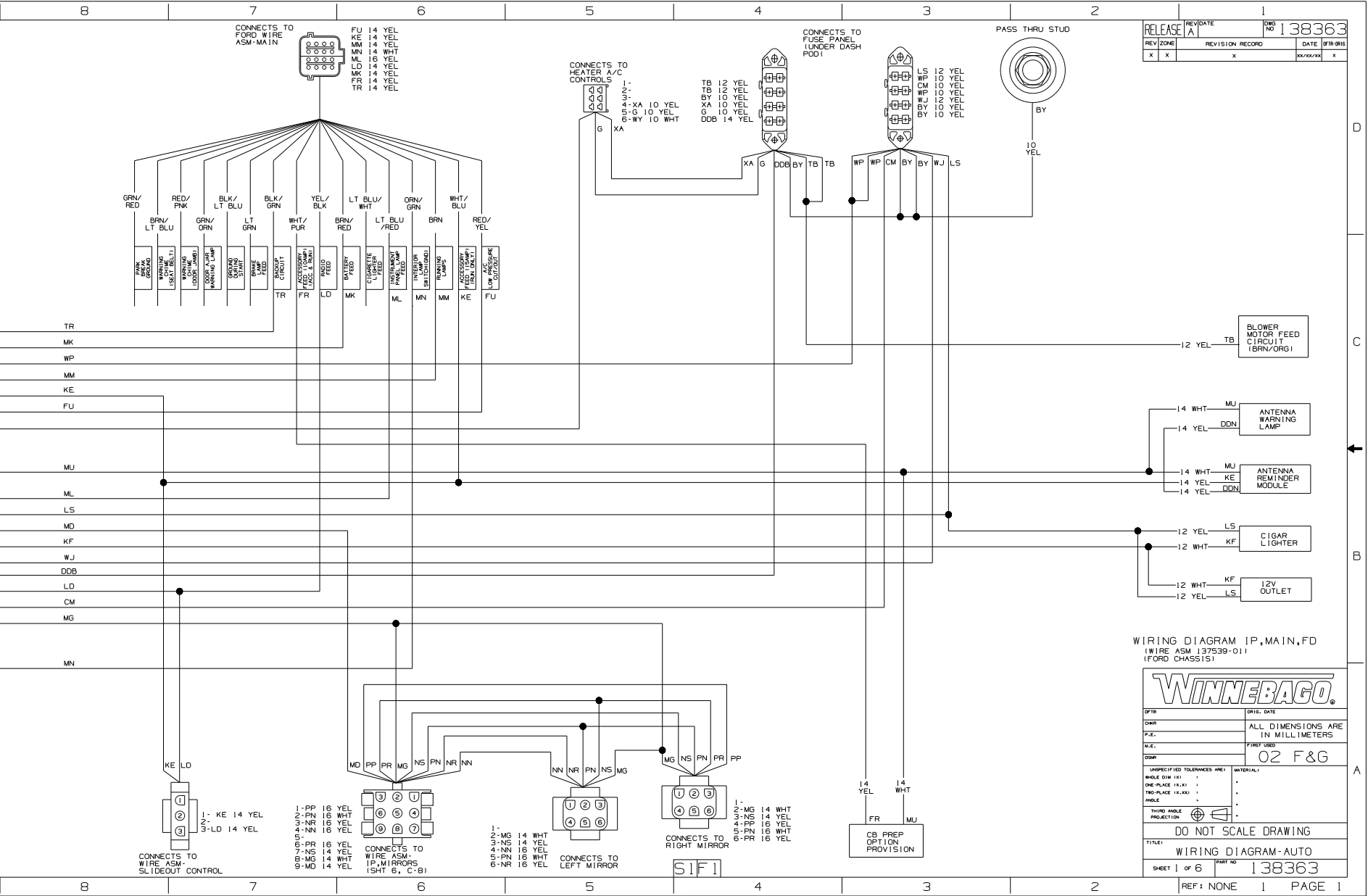

WIRING DIAGRAM IP,MAIN,FD
(WIRE ASM 137539-01)
(FORD CHASSIS)

WINNEBAGO

DATE: _____

ALL DIMENSIONS ARE IN MILLIMETERS

FIRST USED: _____

02 F&G

UNSPECIFIED TOLERANCES ARE:

FRONT VIEW	MATERIAL:
ONE-PLACE (1X, 2X)	
TWO-PLACE (1X, 2X)	
THREE-PLACE (1X, 2X)	
FOUR-PLACE (1X, 2X)	
FIFTH PLACE (1X, 2X)	

THIRD ANGLE PROJECTION

DO NOT SCALE DRAWING

TITLE: WIRING DIAGRAM-AUTO

SHEET 1 OF 6 PART NO 138363

REF: NONE 1 PAGE 1

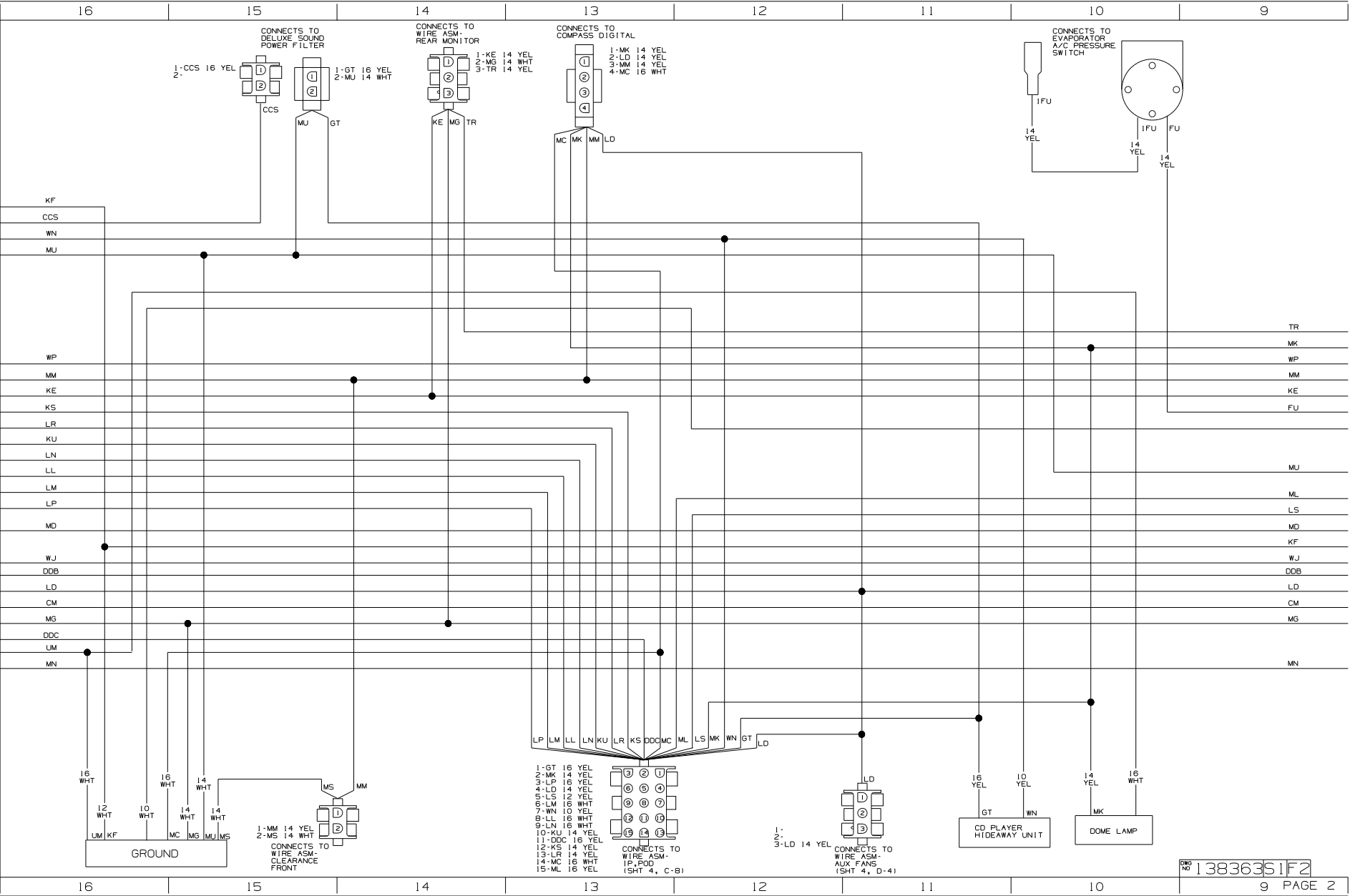

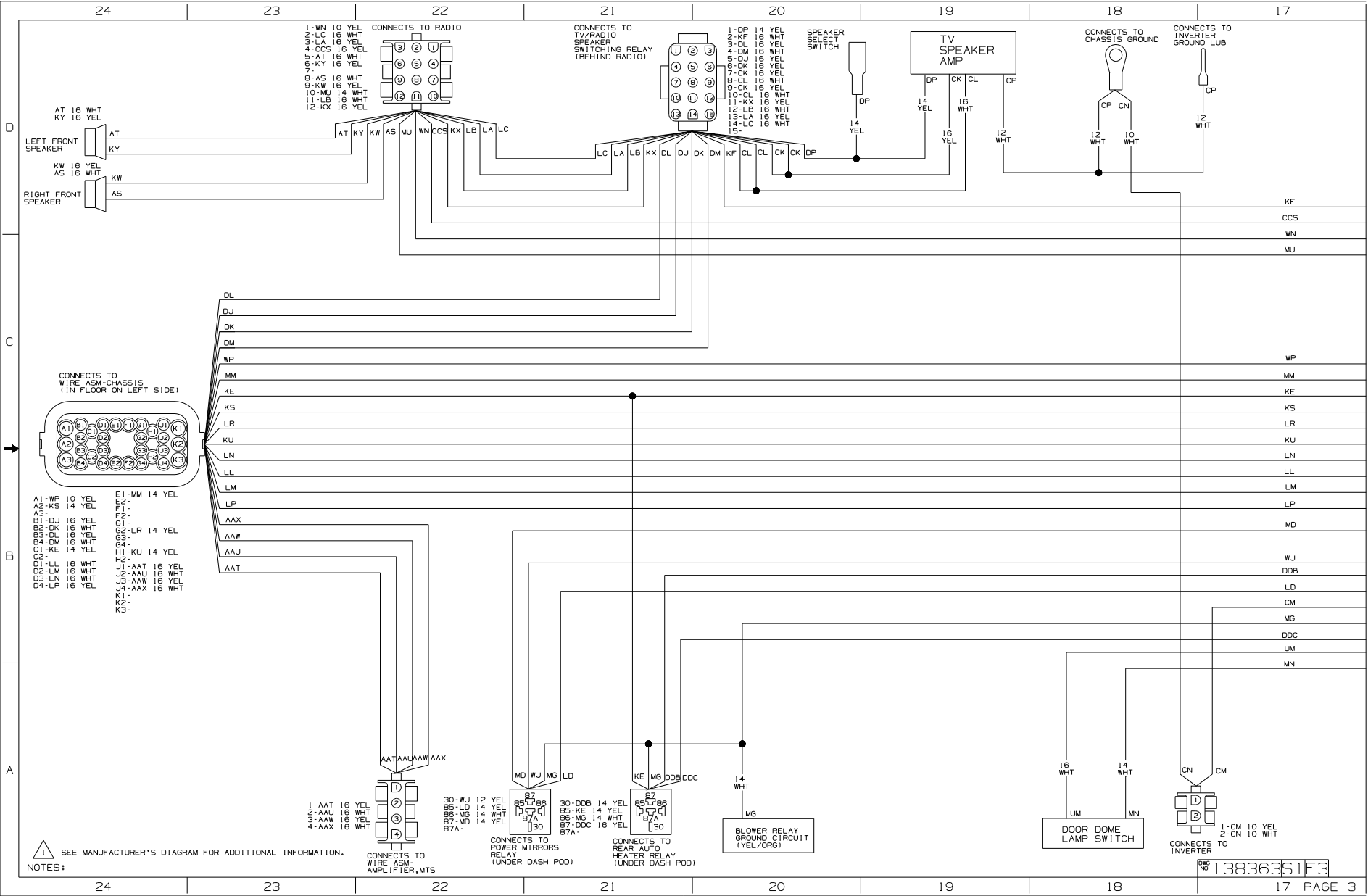

FUSE BLOCK (UNDER DASH POD)

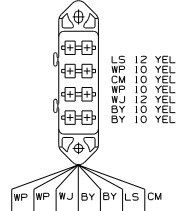

CONNECTS TO COMPASS DIGITAL

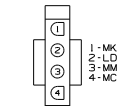

- 1-MK 14 YEL
- 2-LD 14 YEL
- 3-MM 14 YEL
- 4-MC 16 WHT

MM MK LD MC

CONNECTS TO WIRE ASM-REAR MONITOR

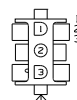

- 1-KE 14 YEL
- 2-MG 14 WHT
- 3-TR 14 YEL

TR MG KE

CIGAR LIGHTER



LS KF

ANTENNA REMINDER MODULE

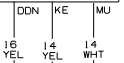

DDN KE MU

CCS
MU
MK
LD
WJ
TR
BY
MM
MG
CN
WP
KE
GT
KF
LS
MC

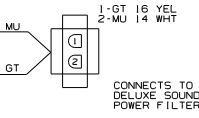

1-GT 16 YEL
2-MU 14 WHT
CONNECTS TO DELUXE SOUND POWER FILTER

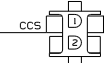

1-CCS 16 YEL
2-

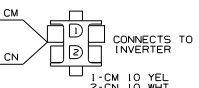

CONNECTS TO INVERTER
1-CM 10 YEL
2-CN 10 WHT

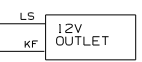

12V OUTLET
12 YEL LS
12 WHT KF



- 1-KE 14 YEL
- 2-LD 14 YEL
- 3-LD 14 YEL

CONNECTS TO WIRE ASM-SLIDEOUT CONTROL



- 1-CW 14 YEL
- 2-KE 14 YEL

CONNECTS TO WIRE ASM-DRL

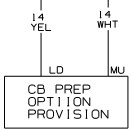

14 YEL LD
14 WHT MU
CB PREP OPTION PROVISION

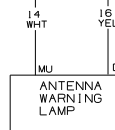

14 WHT MU
16 YEL DDN
ANTENNA WARNING LAMP

SXF 1

WIRING DIAGRAM IP, MAIN
WIRE ASM 137540-011
(WORKHORSE)

FIRST USED	02 F&G SER
TITLE	DO NOT SCALE DRAWING
WIRING DIAGRAM-AUTO	
SHEET 2	PART NO 138363

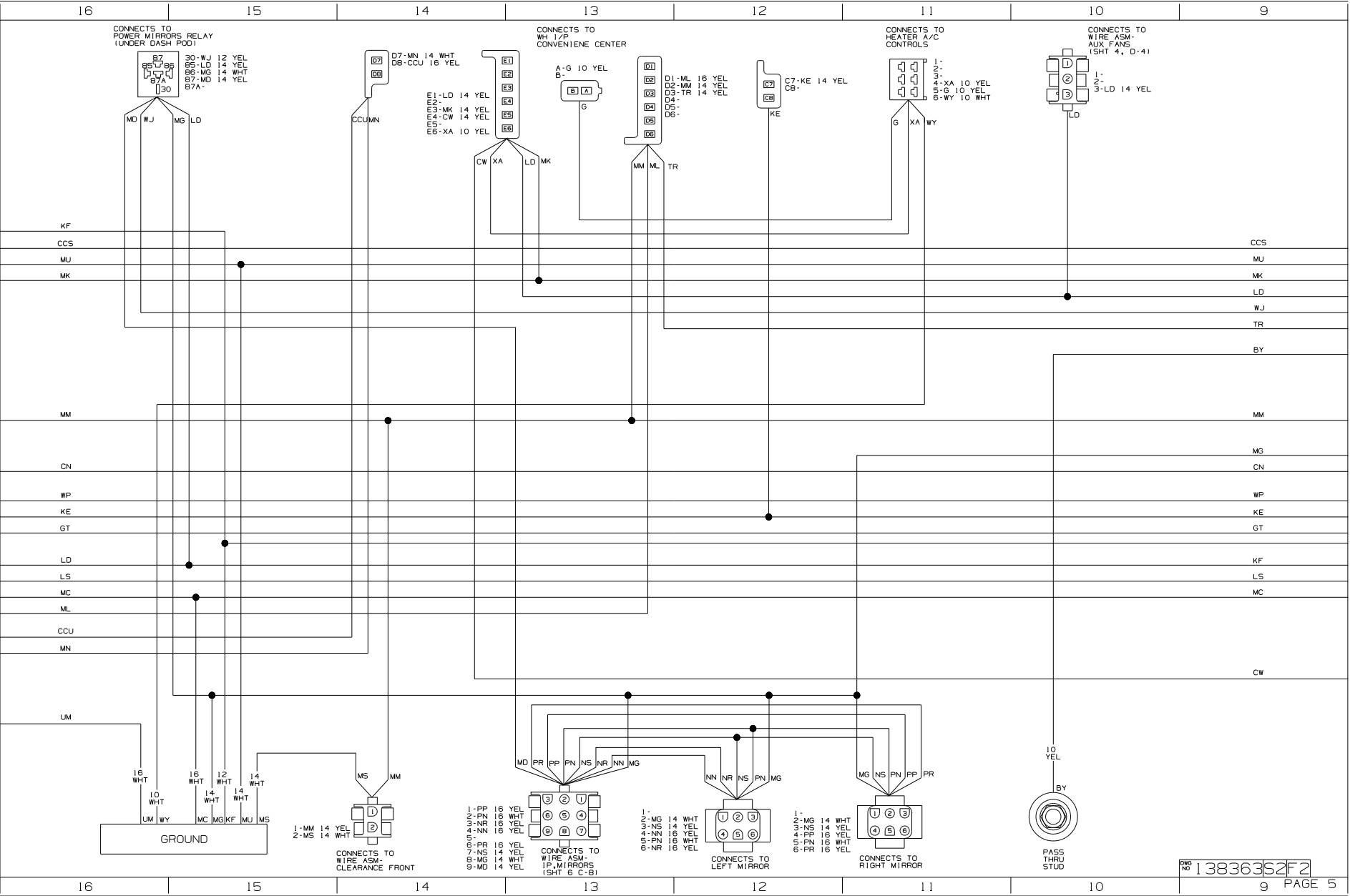

CONNECTS TO
POWER MIRRORS RELAY
(UNDER DASH POD)

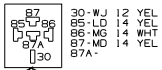

30-WJ 12 YEL
85-LD 14 YEL
86-MG 14 WHT
87-MD 14 YEL
87A* 14 YEL

MD WJ MS LD

CONNECTS TO
WH 1/2 P
CONVENIENCE CENTER



E1-LD 14 YEL
E2-
E3-MK 14 YEL
E4-CW 14 YEL
E5-
E6-XA 10 YEL

CW XA LD MK

CONNECTS TO
HEATER A/C
CONTROLS

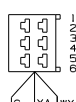

1-
2-
3-
4-XA 10 YEL
5-G 10 YEL
6-WY 10 WHT

G XA WY

CONNECTS TO
WIRE ASM-
AUX FANS
(SHT 4, D-4)

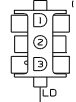

1-
2-
3-LD 14 YEL

LD

KF

CCS

MU

MK

CCS

MU

MK

LD

WJ

TR

BY

MM

MM

CN

CN

WP

WP

KE

KE

GT

GT

LD

KF

LS

LS

MC

MC

ML

CCU

CW

UM

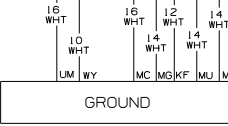

GROUND

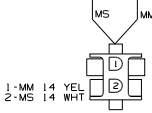

1-MM 14 YEL
2-MS 14 WHT

CONNECTS TO
WIRE ASM-
CLEARANCE FRONT

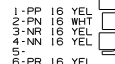

1-PP 16 YEL
2-PN 16 WHT
3-NR 16 YEL
4-NN 16 YEL
5-
6-
7-PR 16 YEL
8-NS 14 YEL
9-MD 14 YEL

CONNECTS TO
WIRE ASM-
MIRRORS
(SHT 6 C-B)

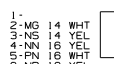

1-
2-MG 14 WHT
3-NS 14 YEL
4-NN 16 YEL
5-PN 16 WHT
6-NR 16 YEL

CONNECTS TO
LEFT MIRROR

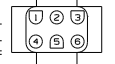

1-
2-MG 14 WHT
3-NS 14 YEL
4-PP 16 YEL
5-PN 16 WHT
6-PR 16 YEL

CONNECTS TO
RIGHT MIRROR

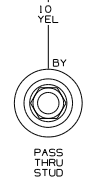

10 YEL
PASS
THRU
STUD

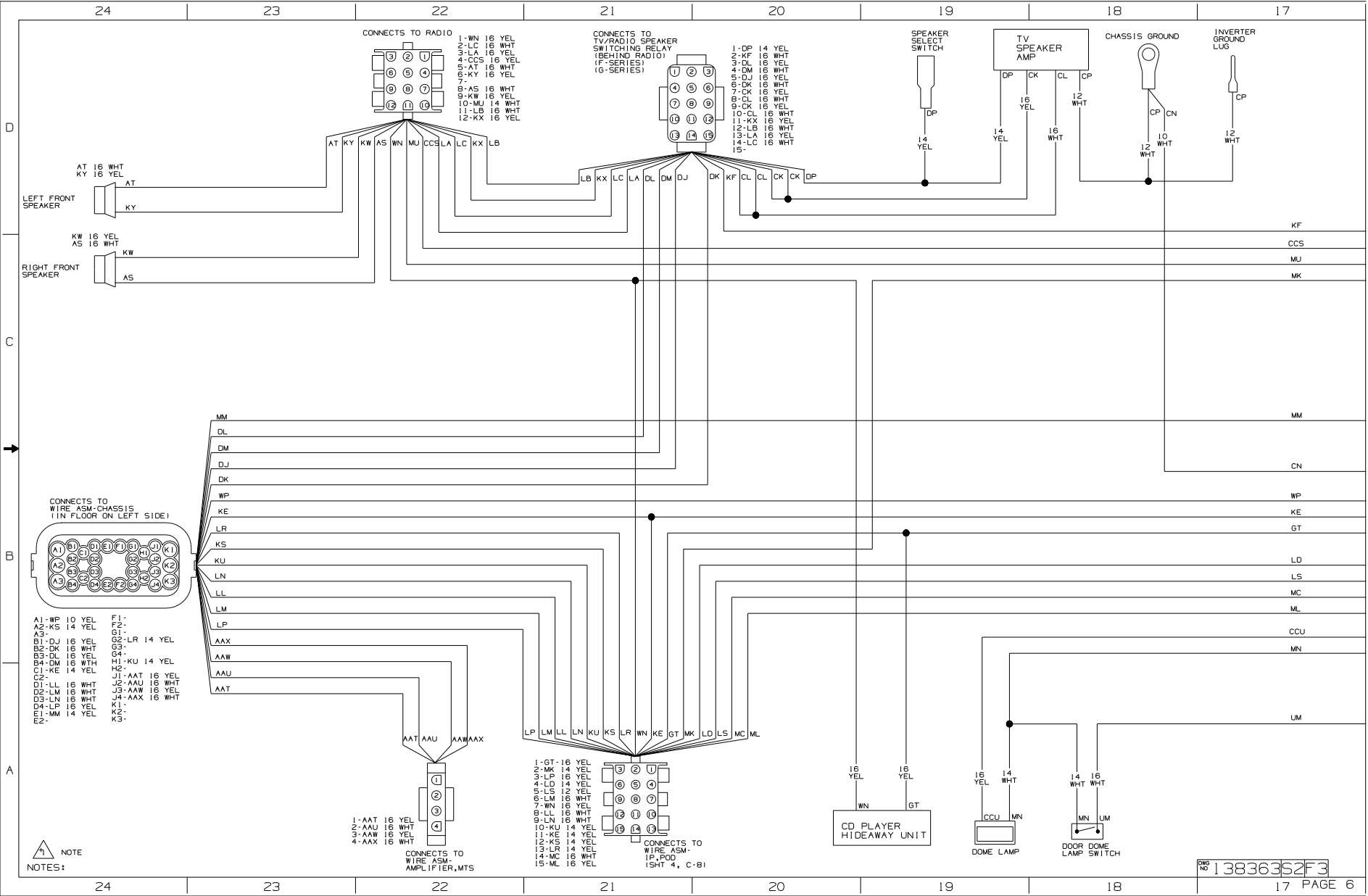

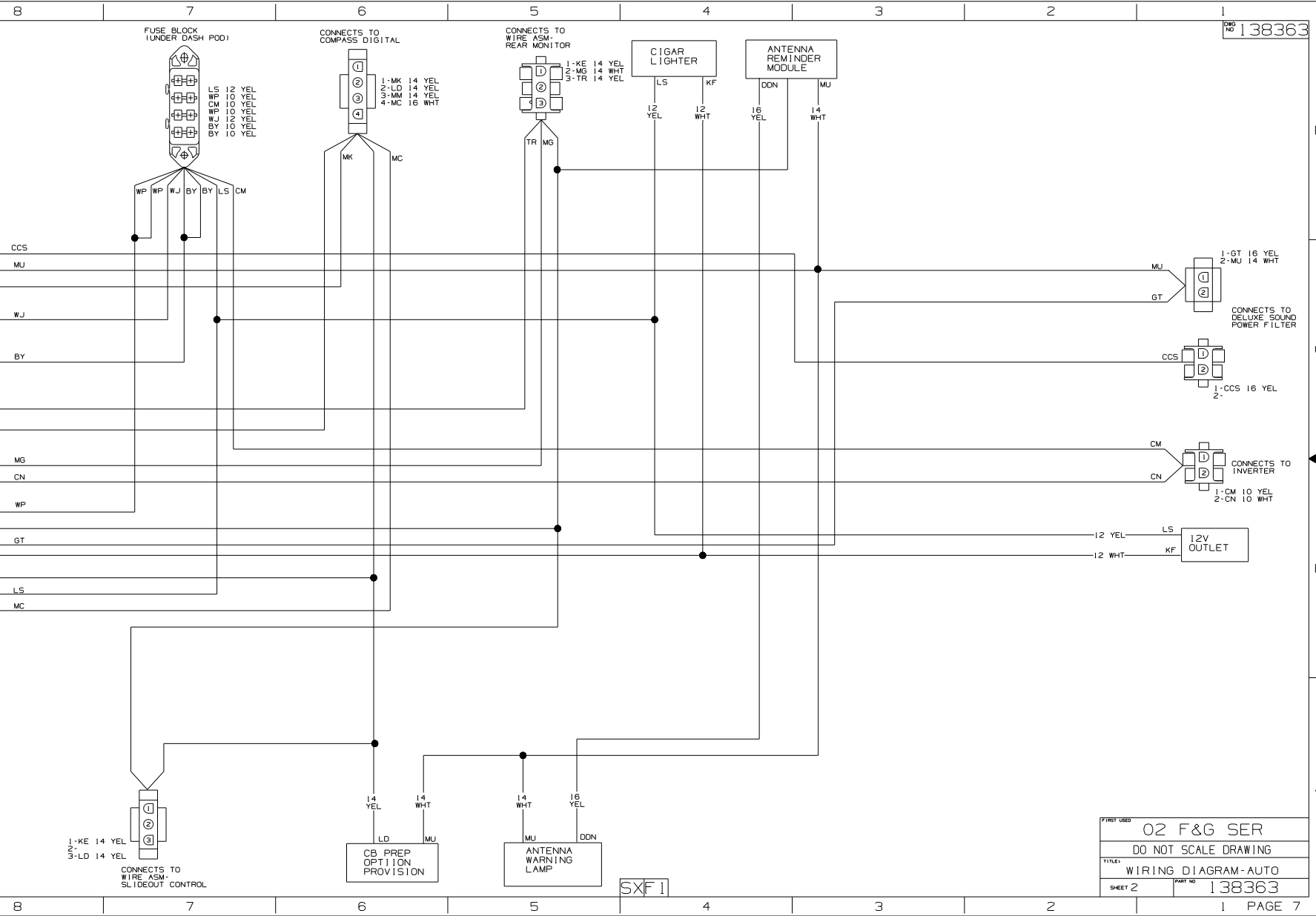

FIRST USED	02 F&G SER
TITLE	DO NOT SCALE DRAWING
WIRING DIAGRAM-AUTO	
SHEET 2	PART NO 138363

SXF1

D

C

B

A

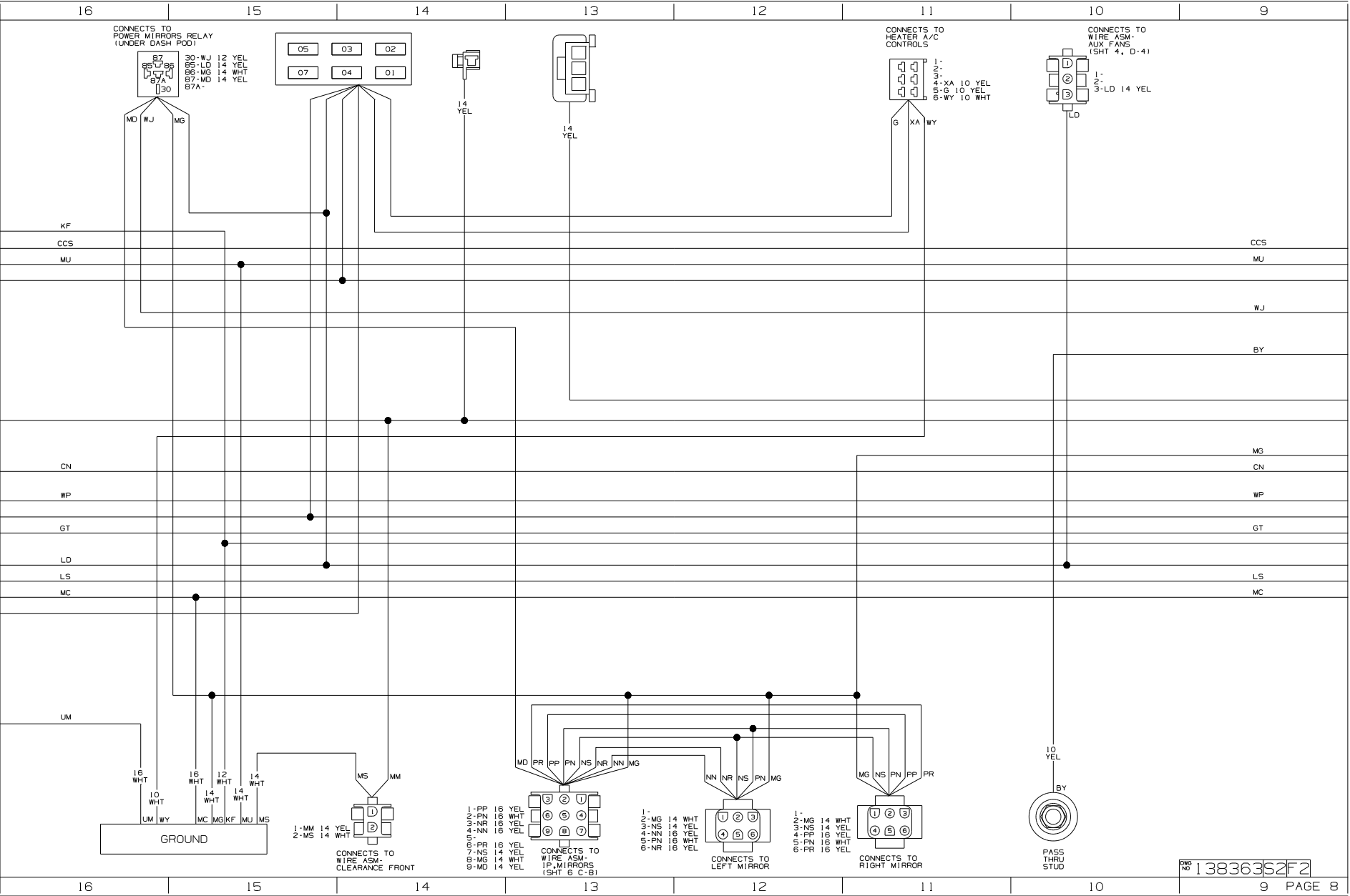

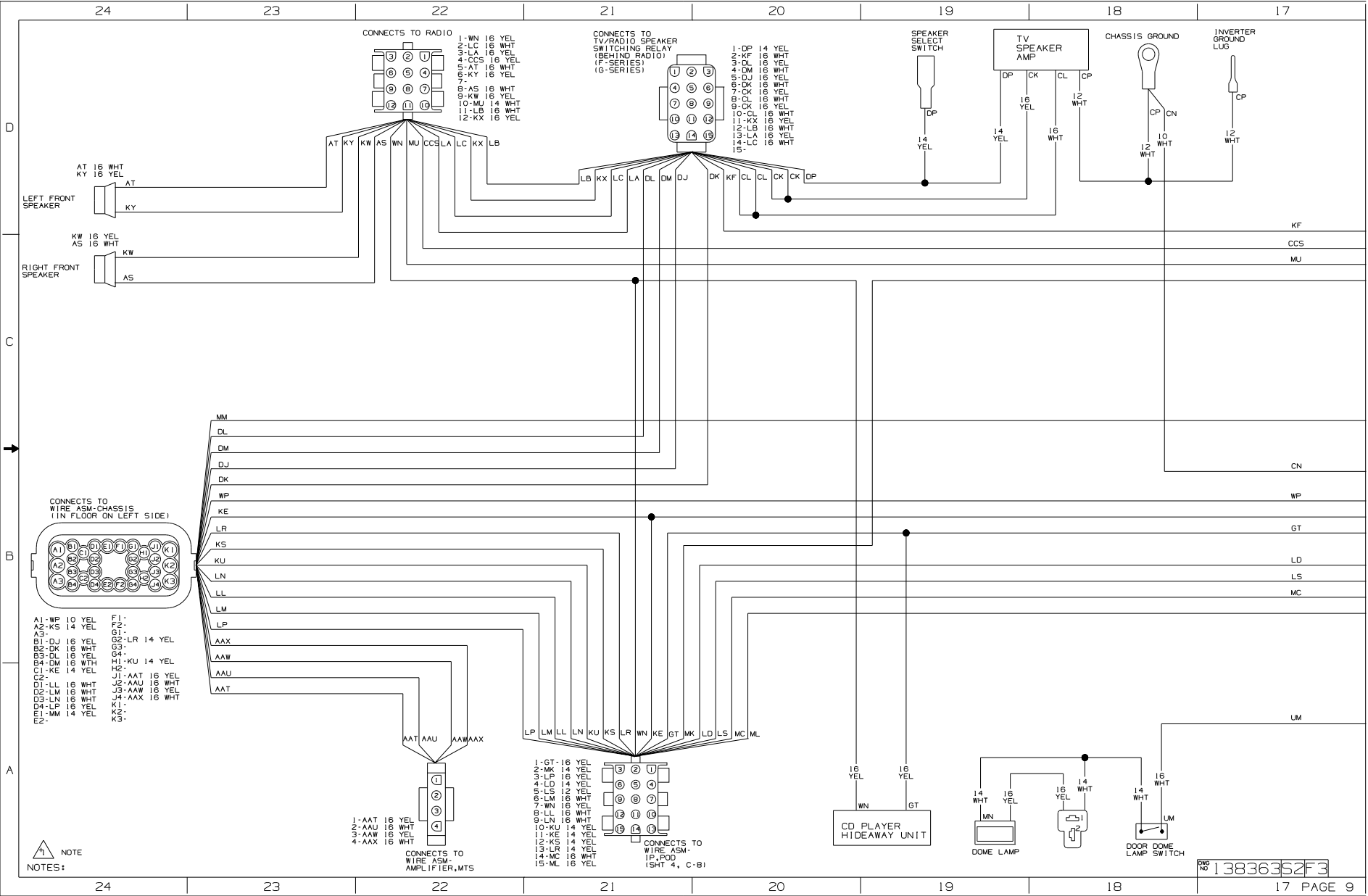

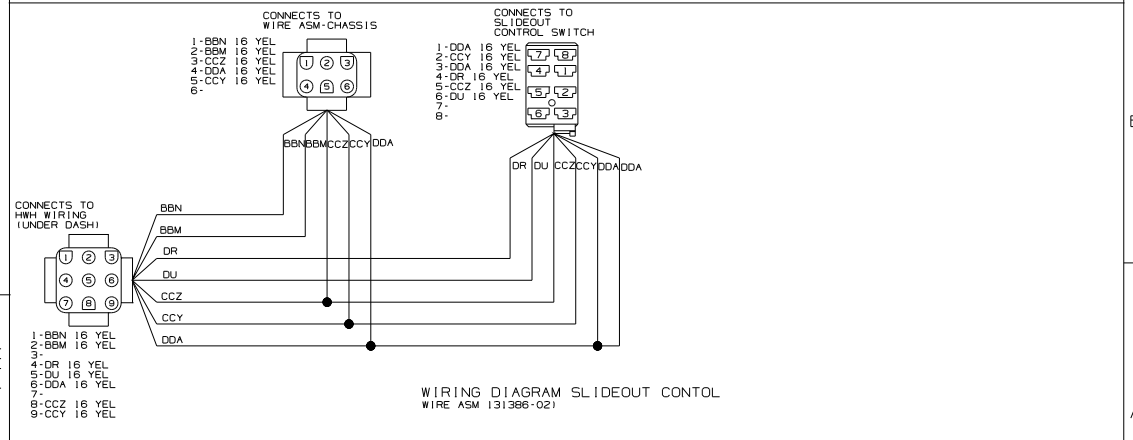
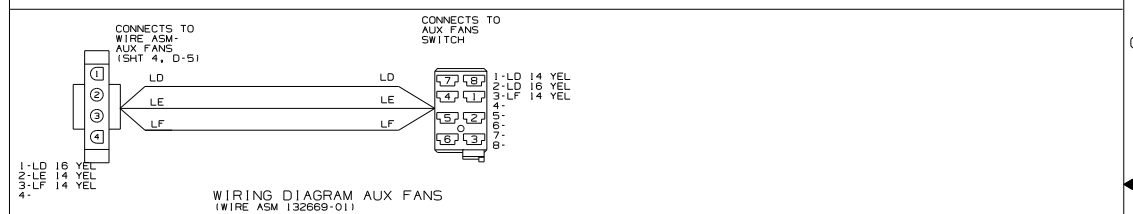
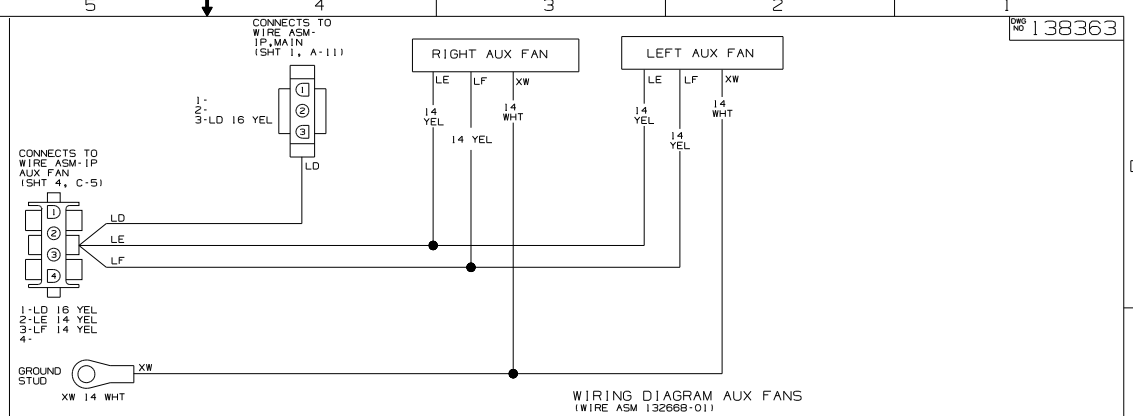
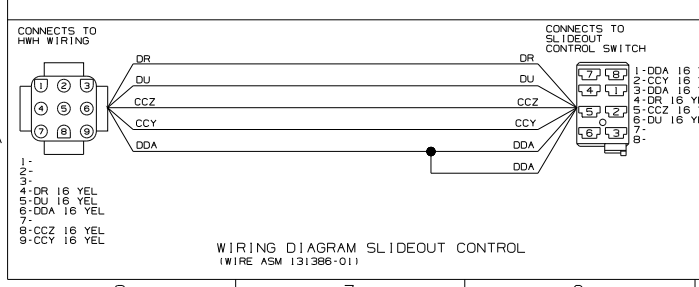
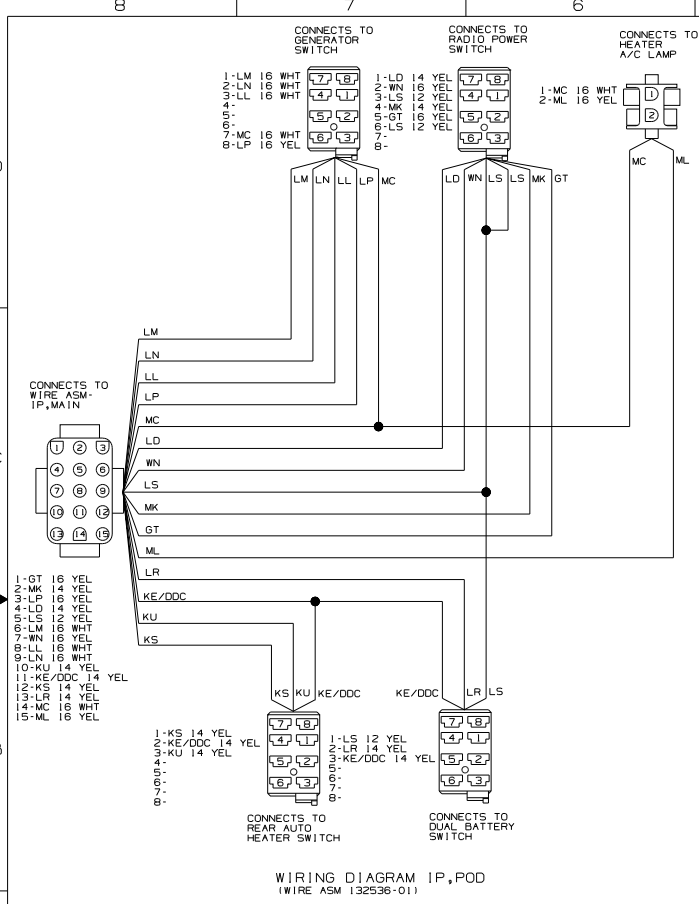

FIRST USED	02 F&G SER
TITLE:	DO NOT SCALE DRAWING
WIRING DIAGRAM-AUTO	
SHEET 4	PART NO 138363

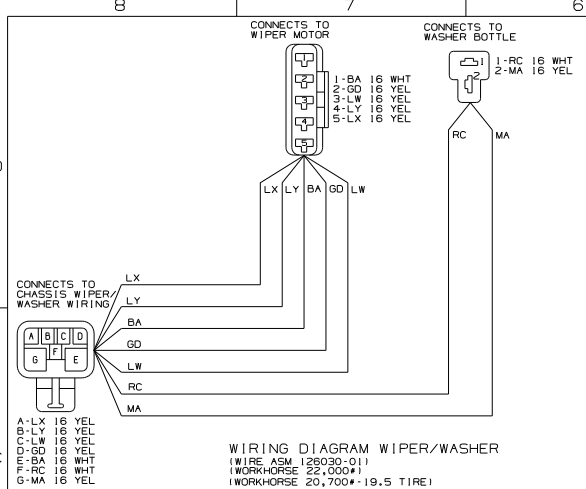

WIRING DIAGRAM WIPER/WASHER
(WIRE ASM 126030-01)
(WORKHORSE 22,000#1)
(WORKHORSE 20,700#-19.5 TIRE)

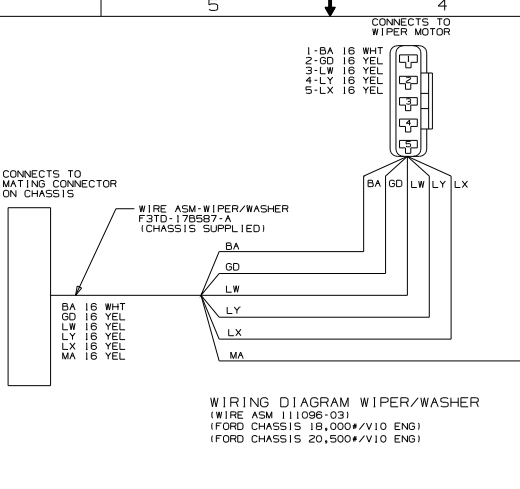

WIRING DIAGRAM WIPER/WASHER
(WIRE ASM 111096-03)
(FORD CHASSIS 18,000#/V10 ENG)
(FORD CHASSIS 20,500#/V10 ENG)

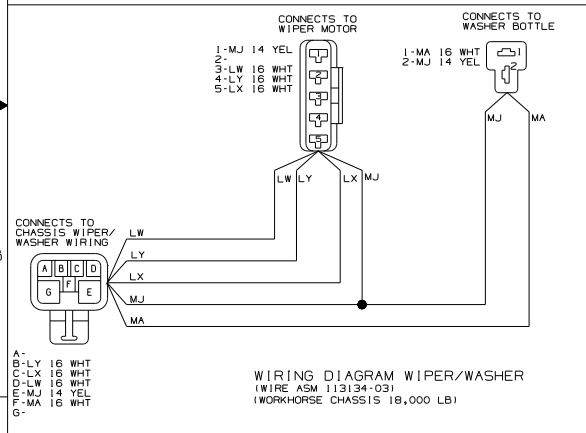

WIRING DIAGRAM WIPER/WASHER
(WIRE ASM 113134-03)
(WORKHORSE CHASSIS 18,000 LB)

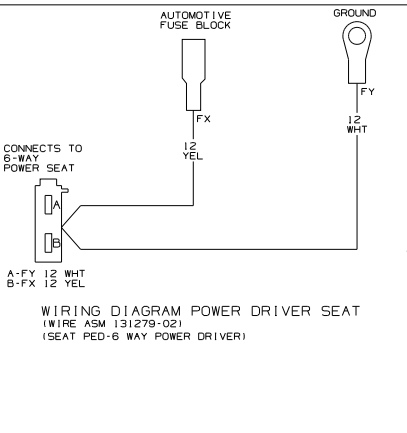

WIRING DIAGRAM POWER DRIVER SEAT
(WIRE ASM 131279-02)
(SEAT PED-6 WAY POWER DRIVER)

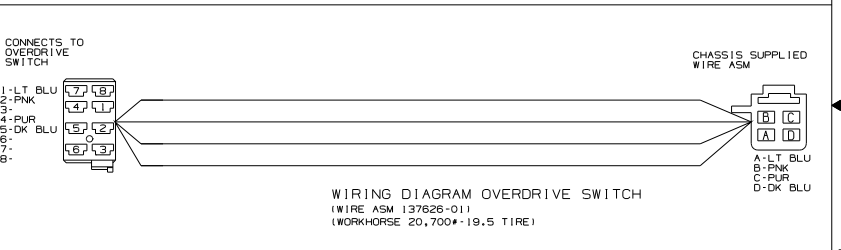

WIRING DIAGRAM OVERDRIVE SWITCH
(WIRE ASM 137626-01)
(WORKHORSE 20,700#-19.5 TIRE)

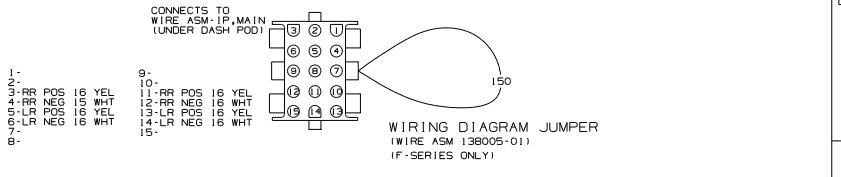

WIRING DIAGRAM JUMPER
(WIRE ASM 138005-01)
(F-SERIES ONLY)

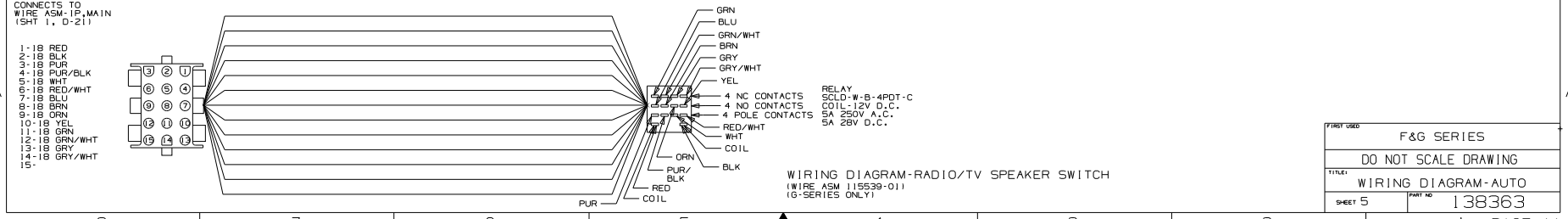

WIRING DIAGRAM-RADIO/TV SPEAKER SWITCH
(WIRE ASM 115539-01)
(G-SERIES ONLY)

FIRST USED	F&G SERIES
DO NOT SCALE DRAWING	
TITLE: WIRING DIAGRAM-AUTO	
SHEET 5	PART NO 138363

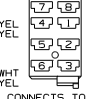
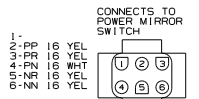

WIRING DIAGRAM IP POWER, MIRROR
(WIRE ASM 129436-02)
(F-SERIES ONLY)



WIRING DIAGRAM SPEAKER, ADAPTER
(WIRE ASM 124843-02)



WIRING DIAGRAM SPEAKER, ADAPTER
(WIRE ASM 124843-03)

FIRST USED	02 F&G SER
TITLE	DO NOT SCALE DRAWING
SHEET	6
PART NO	138363