



DANGER

Danger of electrical shock, burns or death. Always remove all power sources before attempting any repair, service or diagnostic work. Power can be present from shore power, generator, inverter or battery. All power sources must be disabled and secured before performing any service.



CAUTION

If you lack the skills, tools or equipment to perform diagnostic or repair work leave such work to an authorized Winnebago Industries dealer or other qualified shop.

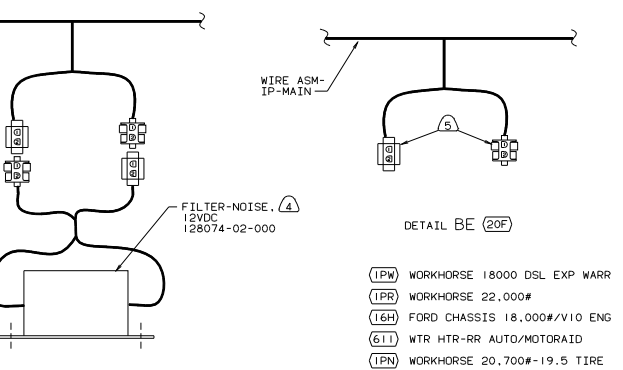
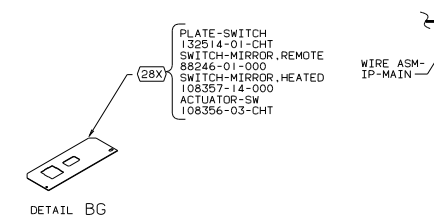
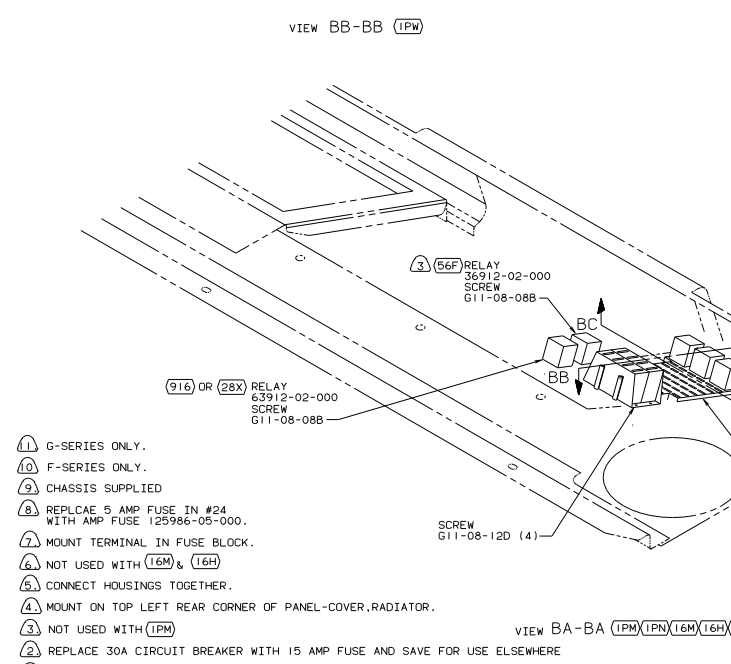
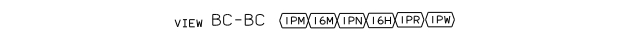
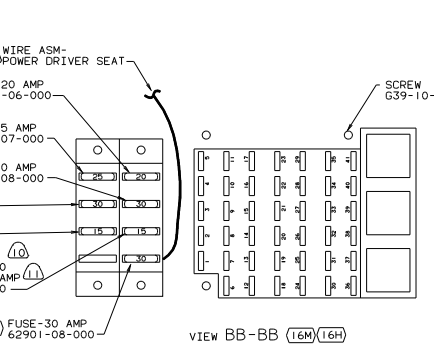
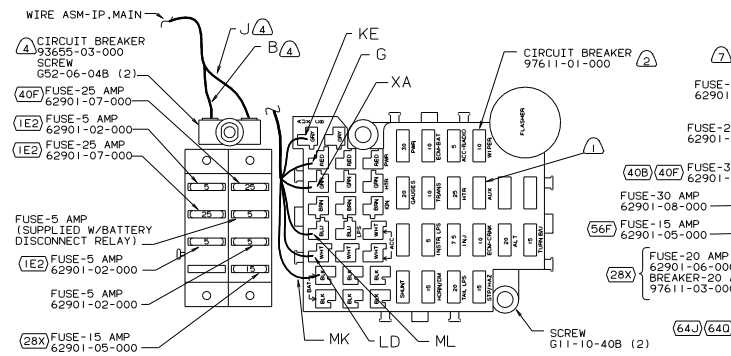
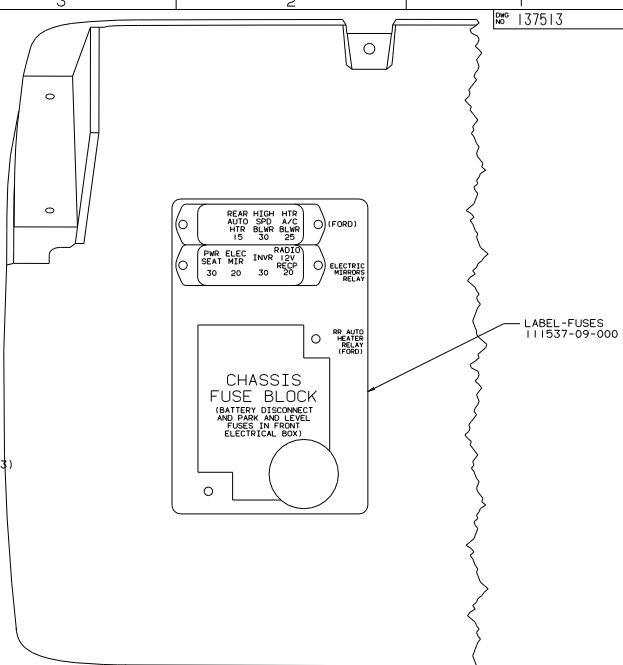
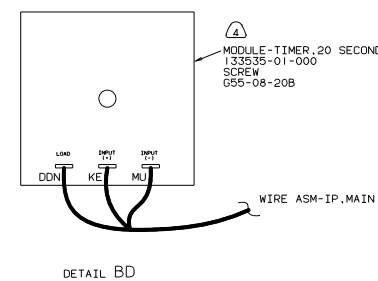
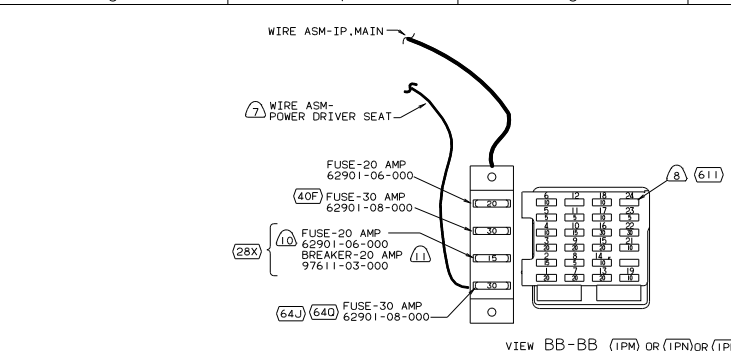

- ① G-SERIES ONLY.
- ⑩ F-SERIES ONLY.
- ⑨ CHASSIS SUPPLIED
- ⑧ REPLAC 5 AMP FUSE IN #24 WITH AMP FUSE 125986-05-000.
- ⑦ MOUNT TERMINAL IN FUSE BLOCK.
- ⑥ NOT USED WITH (16M) & (16H)
- ⑤ CONNECT HOUSINGS TOGETHER.
- ④ MOUNT ON TOP LEFT REAR CORNER OF PANEL-COVER, RADIATOR.
- ③ NOT USED WITH (1PM)
- ② REPLACE 30A CIRCUIT BREAKER WITH 15 AMP FUSE AND SAVE FOR USE ELSEWHERE
- ① TRIM FUSE BLOCK SO CIRCUIT BREAKER FITS PROPERLY. REPLACE 25 AMP FUSE AND SAVE FOR USE ELSEWHERE.

- (1PW) WORKHORSE 18000 DSL EXP WARR
- (1PR) WORKHORSE 22,000#
- (16H) FORD CHASSIS 18,000#/V10 ENG
- (611) WTR HTR-RR AUTO/MOTORAID
- (1PN) WORKHORSE 20,700#-19.5 TIRE
- (20C) SOUND SYS. DLX. W/O-SURROUND
- (40B) INVERTER-DC/AC, 300 WATT
- (64J) SEAT PED-6-WAY DR/PASS POWER
- (21V) SOUND SYSTEM DELUXE
- (20F) DELUXE SOUND SYSTEM-WITHOUT
- (16M) FORD CHASSIS 20,500#/V10 ENG
- (1PM) WORKHORSE CHASSIS-18,000LB.
- (916) MIRRORS-EXTERIOR, EXPORT
- (64D) SEAT PED-6-WAY POWER DRIVER
- (56F) HEATER-AUXILIARY AUTOMOTIVE
- (40F) INVERTER-DC/AC-130W
- (28X) MIRRORS-EXTERIOR W/DEFROST

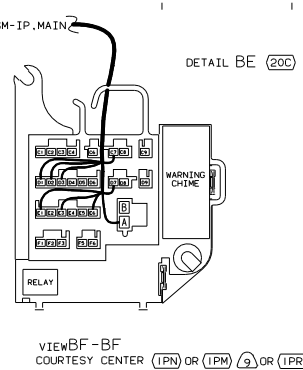

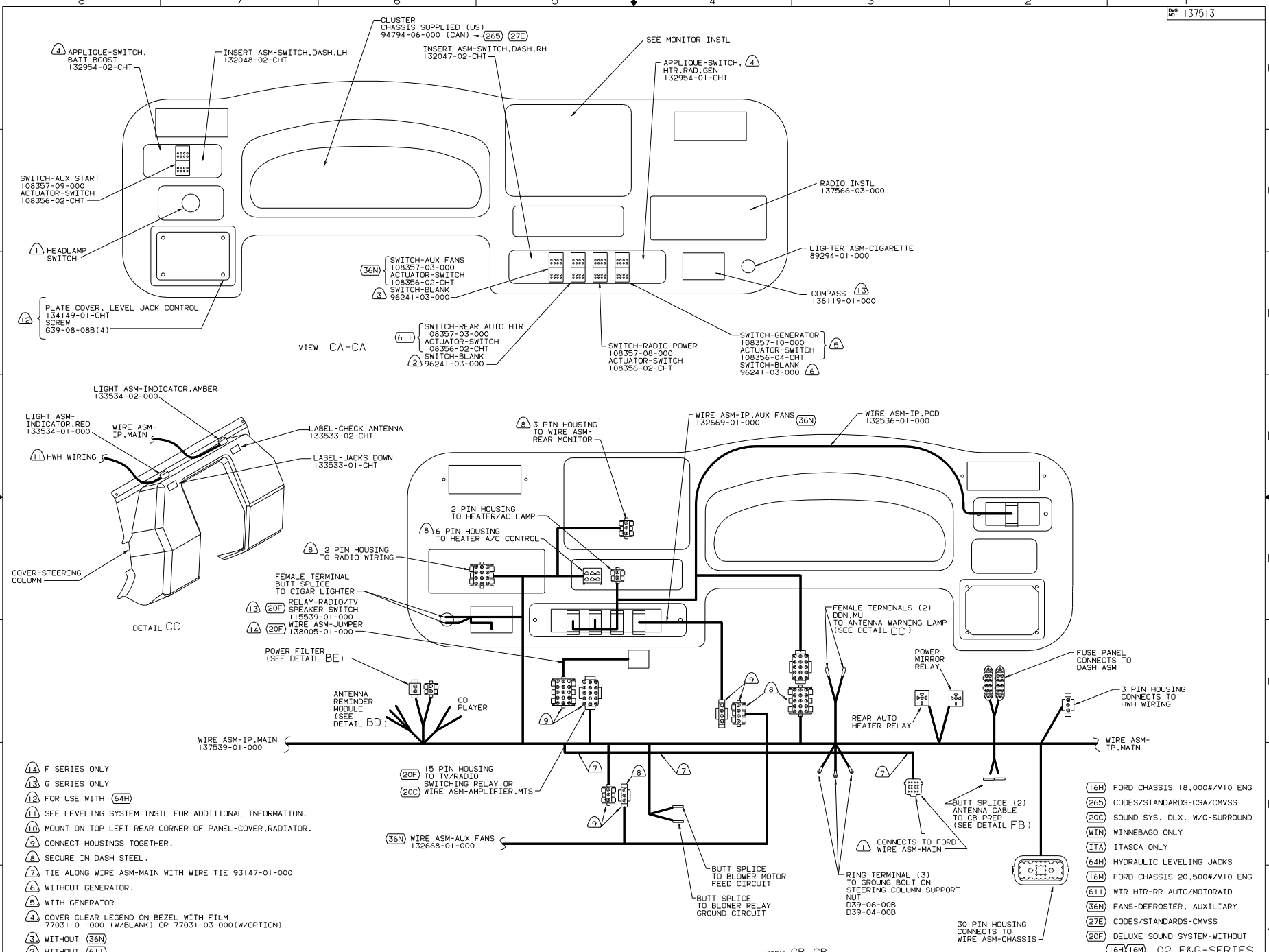

VIEW CA-CA

VIEW CB-CB

- NOTES:
- (14) F SERIES ONLY
 - (13) G SERIES ONLY
 - (12) FOR USE WITH (64H)
 - (11) SEE LEVELING SYSTEM INSTL FOR ADDITIONAL INFORMATION.
 - (10) MOUNT ON TOP LEFT REAR CORNER OF PANEL-COVER, RADIATOR.
 - (9) CONNECT HOUSINGS TOGETHER.
 - (8) SECURE IN DASH STEEL.
 - (7) TIE ALONG WIRE ASM-MAIN WITH WIRE TIE 93147-01-000
 - (6) WITHOUT GENERATOR.
 - (5) WITH GENERATOR
 - (4) COVER CLEAR LEGEND ON BEZEL WITH FILM 77031-01-000 (W/BLANK) OR 77031-03-000 (W/OPTION).
 - (3) WITHOUT (36N)
 - (2) WITHOUT (611)
 - (1) CHASSIS SUPPLIED.

- (16H) FORD CHASSIS 18,000#/V10 ENG
- (26S) CODES/STANDARDS-CSA/CMVSS
- (20C) SOUND SYS. DLX. W/O-SURROUND
- (WIN) WINNEBAGO ONLY
- (ITA) ITASCA ONLY
- (64H) HYDRAULIC LEVELING JACKS
- (16M) FORD CHASSIS 20,500#/V10 ENG
- (611) WTR HTR-RR AUTO/MOTORAID
- (36N) FANS-DEFROSTER, AUXILIARY
- (27E) CODES/STANDARDS-CMVSS
- (20F) DELUXE SOUND SYSTEM-WITHOUT
- (16H)(16M) 02 F&G-SERIES

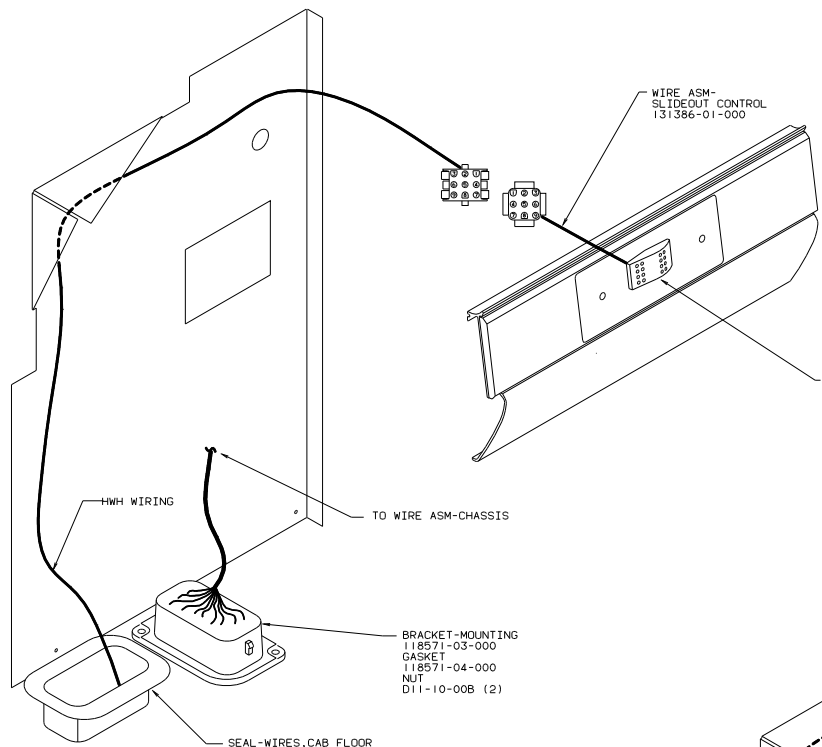

DETAIL EA (09L)
(SLIDEOUT CONTROLS)

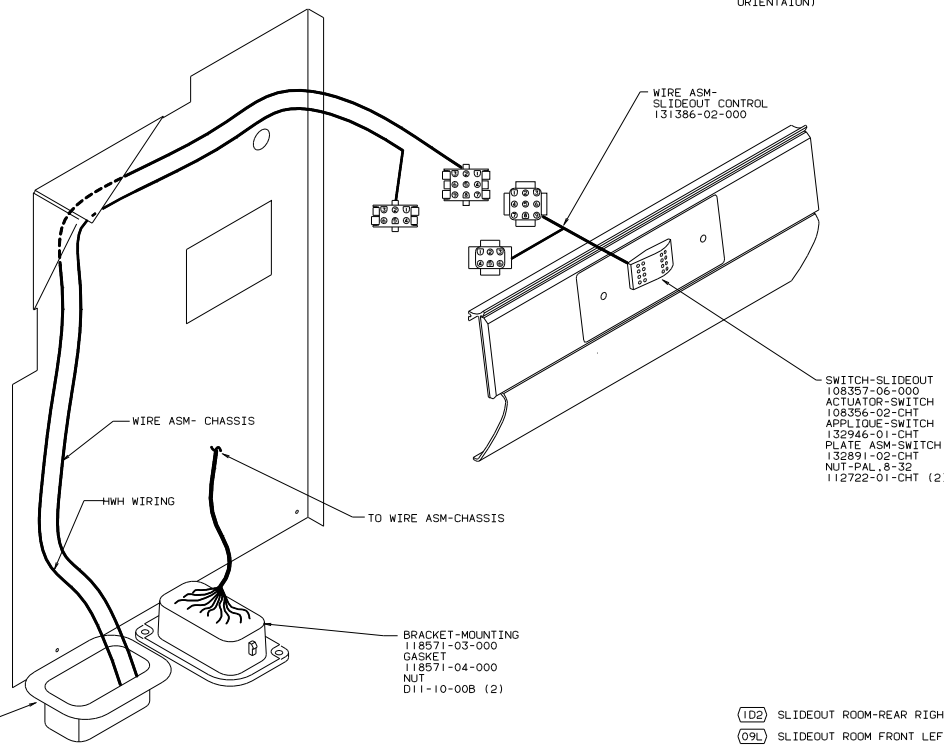

DETAIL EA (09L)(102)
(SLIDEOUT CONTROLS)

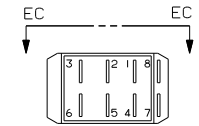

VIEW EB-EB (SWITCH MOUNTING ORIENTATION)

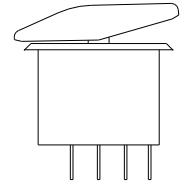

- NOTES:
- (3) SWITCH SHOWN WITHOUT WIRE ASM HOUSING CONNECTED.
 - (2) SAME FOR ALL SWITCHES EXCEPT GENERATOR SWITCH AND AUX START SWITCH.
 - (1) SAME FOR ALL DASH SWITCHES.

- (102) SLIDEOUT ROOM-REAR RIGHTHAND
- (09L) SLIDEOUT ROOM FRONT LEFT

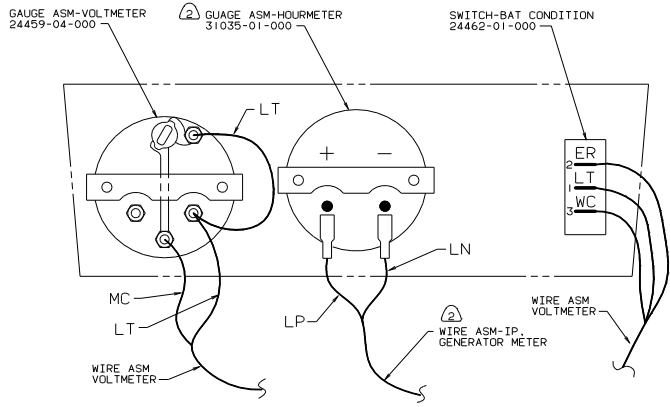

VIEW FA-FA (1)

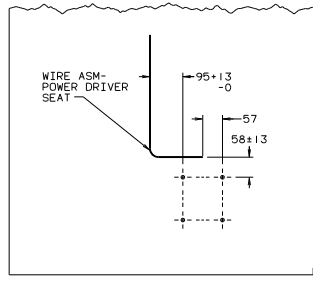

VIEW FB-FB (6) (64D)

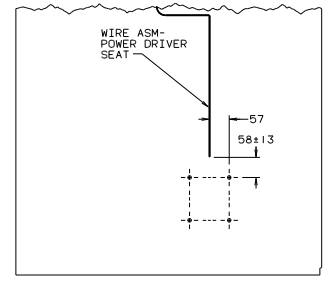

VIEW FD-FD (64J) (6)

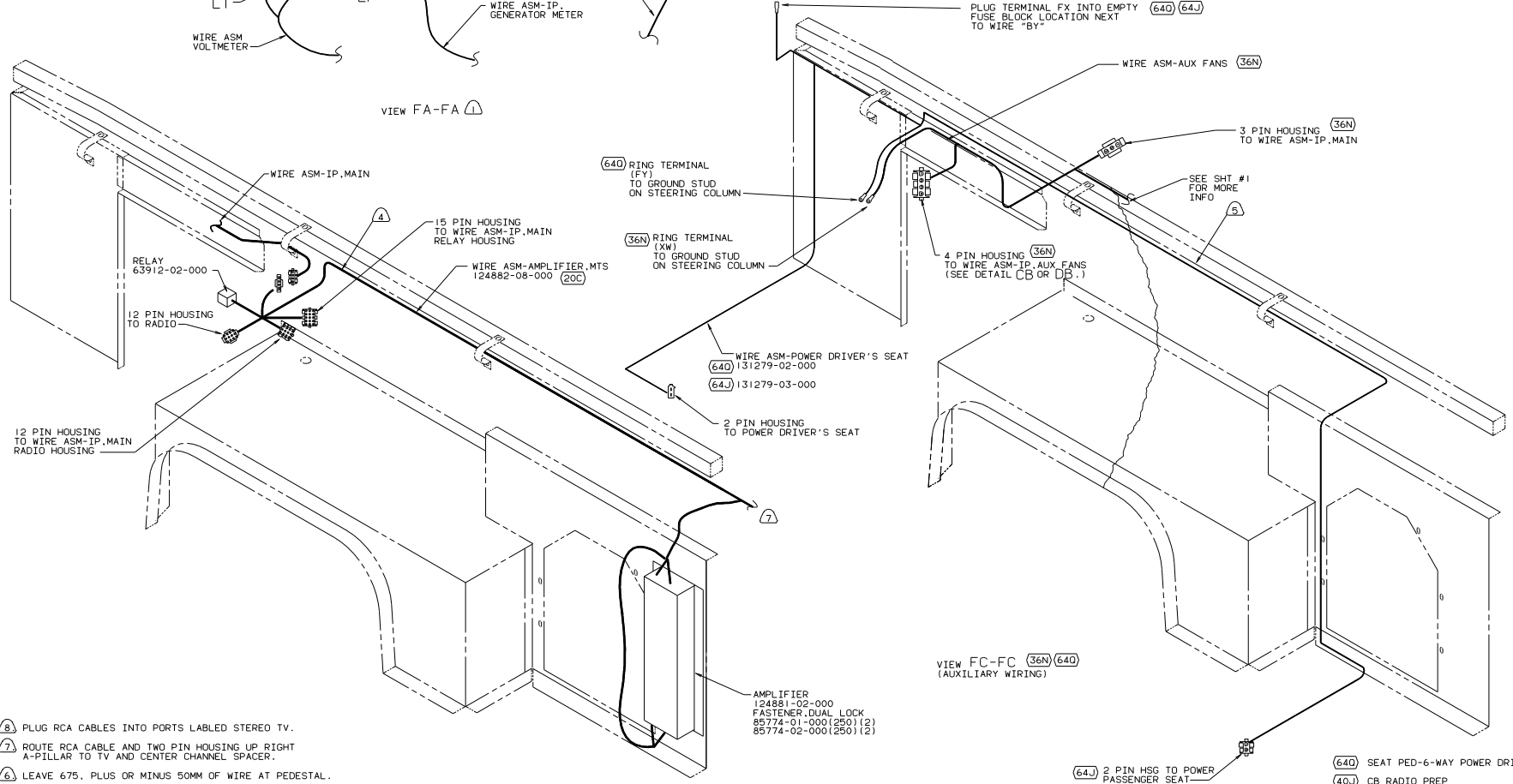

VIEW FC-FC (20C)
(DELUXE SOUND WIRING)

- NOTES:
- (8) PLUG RCA CABLES INTO PORTS LABELED STEREO TV.
 - (7) ROUTE RCA CABLE AND TWO PIN HOUSING UP RIGHT A-PILLAR TO TV AND CENTER CHANNEL SPACER.
 - (6) LEAVE 675. PLUS OR MINUS SOMM OF WIRE AT PEDESTAL.
 - (5) ROUTING WITH (64J) ONLY.
 - (4) ROUTE WITH WIRE ASM-IP.MAIN
 - (3) EDGE OF LABEL TO HANG JUST BELOW BOTTOM OF DASH
 - (2) USE ON SHELL W/GENERATOR.
 - (1) USE WITH SHELLS ONLY.

- (64D) SEAT PED-6-WAY POWER DRIVER
- (40J) CB RADIO PREP
- (36N) FANS-DEFROSTER, AUXILIARY
- (64J) SEAT PED-6-WAY DR/PASS POWER
- (20C) SOUND SYS. DLX. W/O-SURROUND

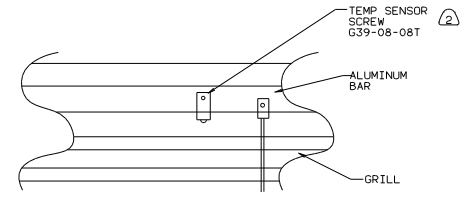
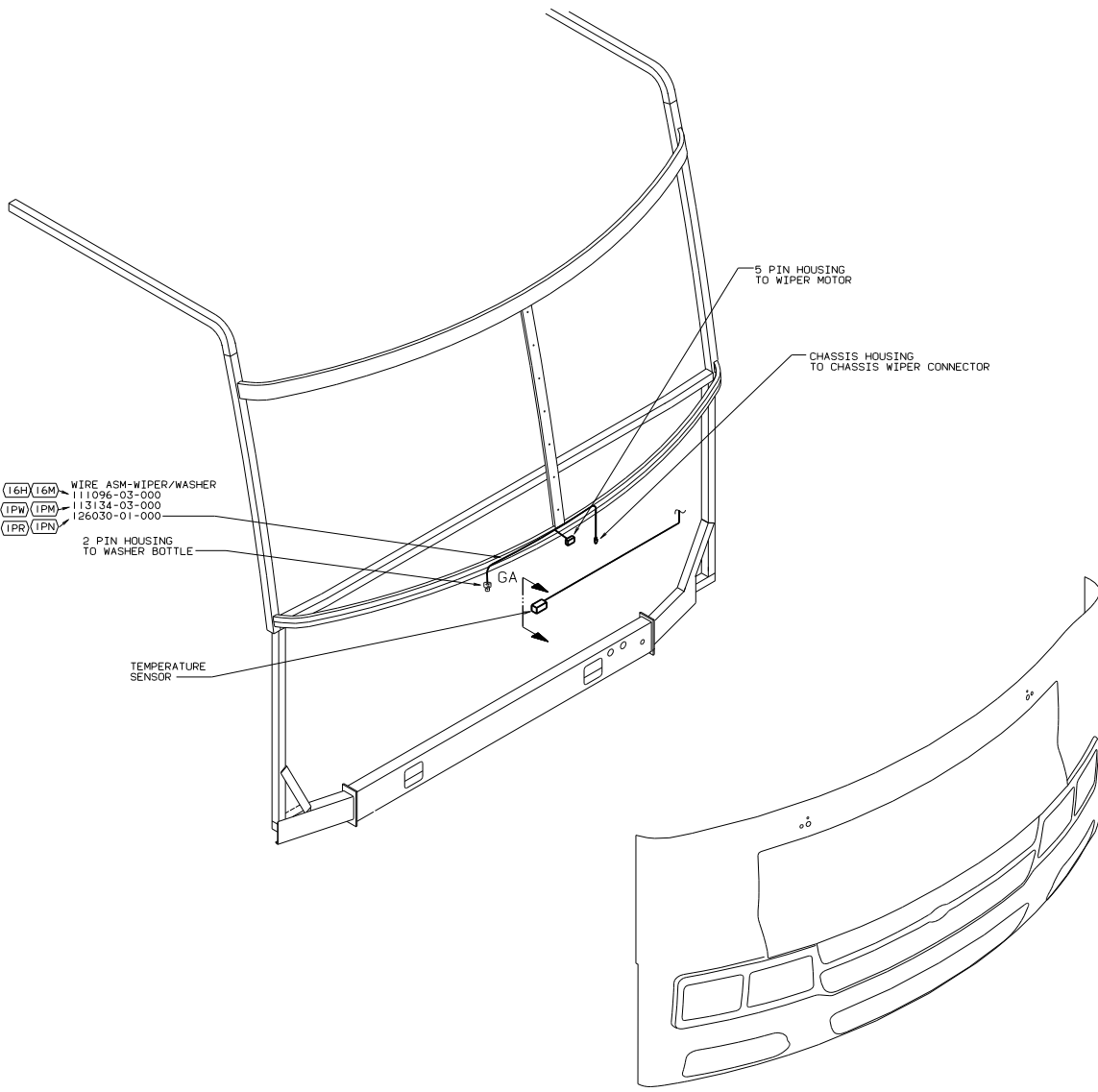

VIEW GA-GA

② MOUNT SENSOR TO HORIZONTAL BAR ABOVE GRILL.

1. GATHER ALL EXCESS WIRE AFTER MAKING ALL CONNECTIONS AND BUNDLE AND SECURE WITH TIE-WIRE 8343-01-000 OR 93147-01-000.

- (1PR) WORKHORSE 22,000#
- (16H) FORD CHASSIS 18,000#V10 ENG
- (1PN) WORKHORSE 20,700#-19.5 TIRE
- (16M) FORD CHASSIS 20,500#V10 ENG
- (1PM) WORKHORSE CHASSIS-18,000LB.

(WIN) 02 F&G-SERIES

TITLE:		WIRING INSTL-FRONT END	
DO NOT SCALE DRAWING	DATE	DRW NO	137513
SHEET 7 OF 8	IF	NO	

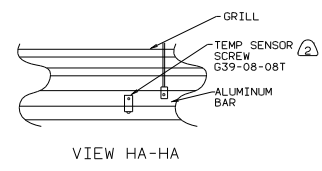
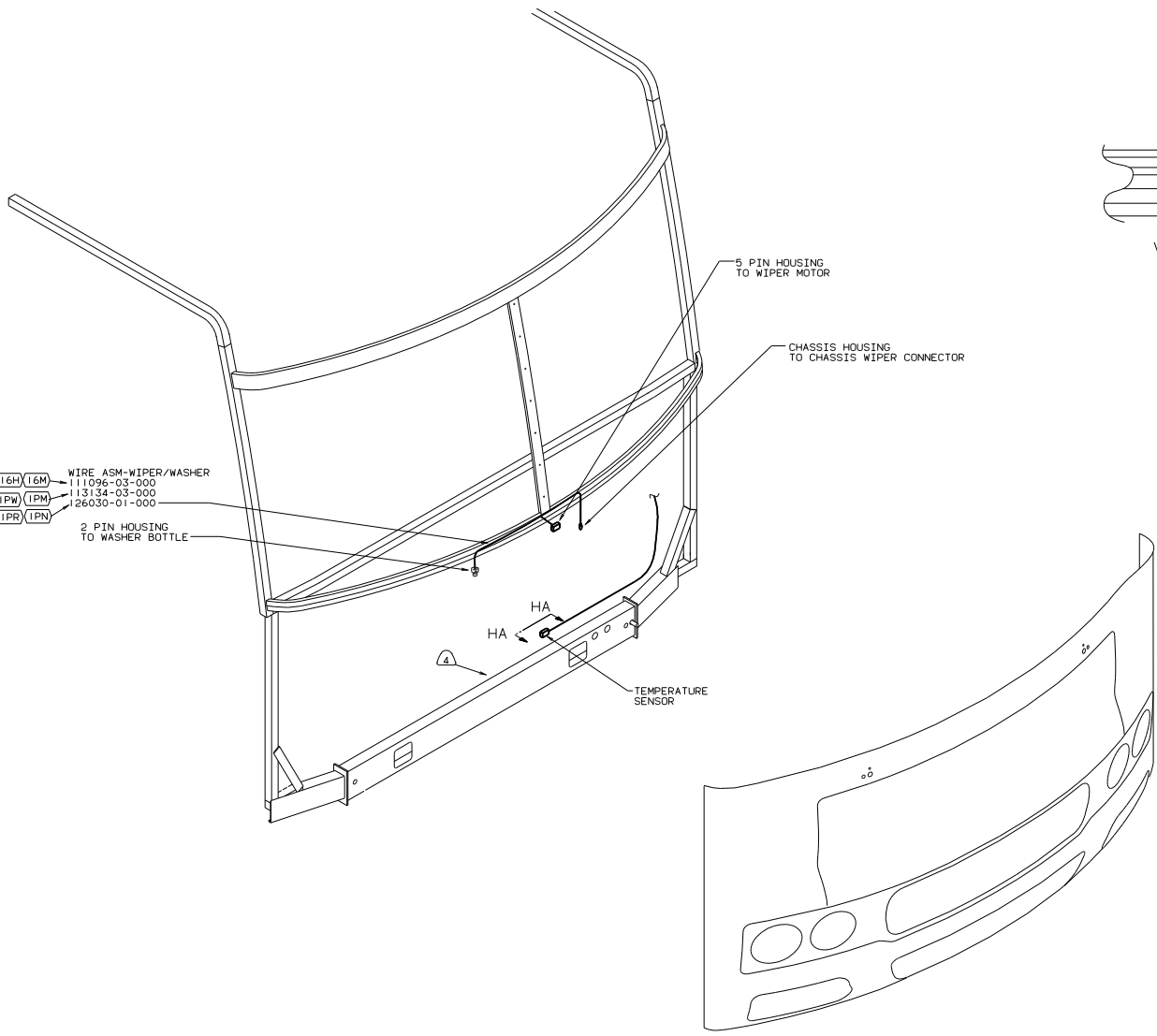

- (16H) (16M) WIRE ASM-WIPER/WASHER
- (1PM) (1PN) 111096-03-000
- (1PM) (1PN) 113134-03-000
- (1PR) (1PN) 126030-01-000

2 PIN HOUSING TO WASHER BOTTLE

TEMPERATURE SENSOR

2 MOUNT SENSOR TO HORIZONTAL BAR BELOW GRILL.
 1. GATHER ALL EXCESS WIRE AFTER MAKING ALL CONNECTIONS AND BUNDLE AND SECURE WITH TIE-WIRE 8343-01-000 OR 93147-01-000.

- (1PR) WORKHORSE 22.000#
- (16H) FORD CHASSIS 18.000#/V10 ENG
- (1PN) WORKHORSE 20.700#-19.5 TIRE
- (1PM) WORKHORSE CHASSIS-18.000LB.
- (16M) FORD CHASSIS 20.500#/V10 ENG

(ITA) 02 F&G-SERIES

TITLE		WIRING INSTL-FRONT END	
DO NOT SCALE DRAWING	DATE	137513	
SHEET 8 OF 8	IF NO		