



DANGER

Danger of electrical shock, burns or death. Always remove all power sources before attempting any repair, service or diagnostic work. Power can be present from shore power, generator, inverter or battery. All power sources must be disabled and secured before performing any service.



CAUTION

If you lack the skills, tools or equipment to perform diagnostic or repair work leave such work to an authorized Winnebago Industries dealer or other qualified shop.

DWG NO	SHEET	DESCRIPTION
133004-01	1	2TK, DIG VOLT
133004-02	2	2T, DIG VOLT, SOLAR
133004-03	3	2TK, W/SOL & PAN
133004-04	4	2TK, W/O WAT HEAT
133004-05	5,6,7	2T, SOLAR/SENSOR

RELEASE	REV DATE	DWG NO
A		133004
REV ZONE	REVISION RECORD	DATE
		DFTR-0R16

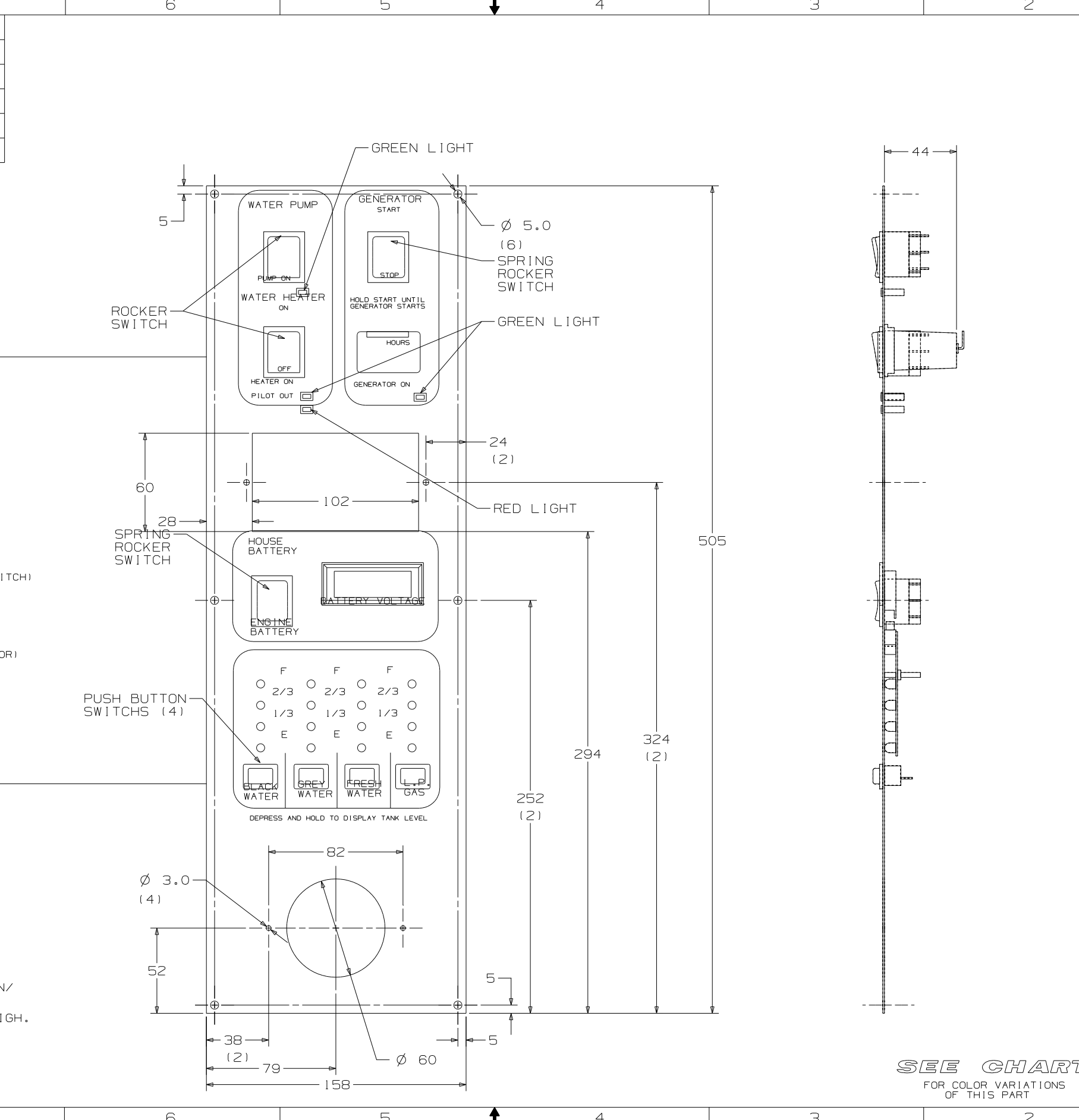
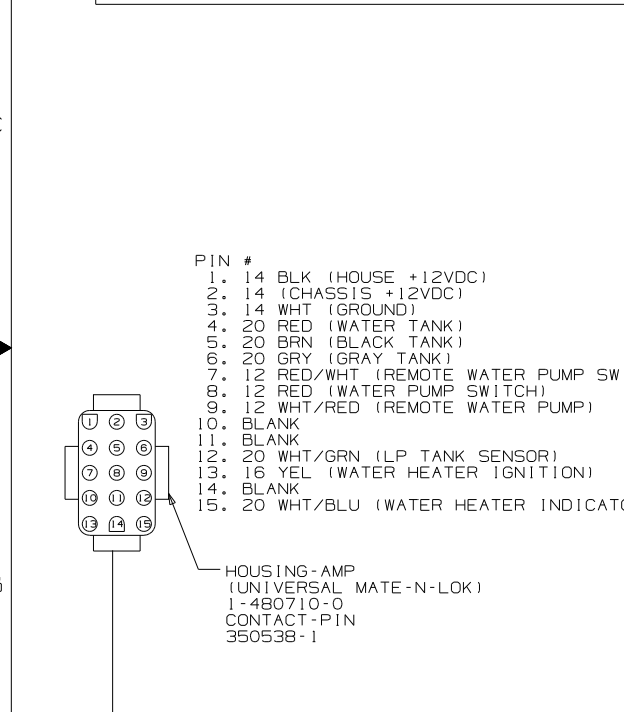
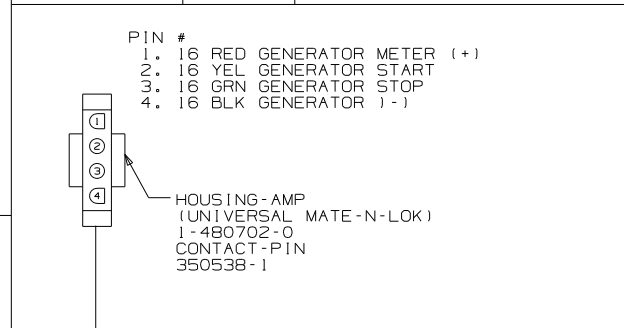

- NOTES:
1. SUGGESTED VENDOR: VENLINE.
 2. BLACK PANEL WITH WHITE GRAPHICS.
 3. LETTERS ON MAIN HEADING TO BE 5MM HIGH.
 4. CUTOUT FOR PANEL TO BE 135 X 350 MIN/
140 X 380 MAX.
 5. SWITCH RATING SHALL BE EMBOSSED ON
THE SIDE OF THE 12V SWITCHES.

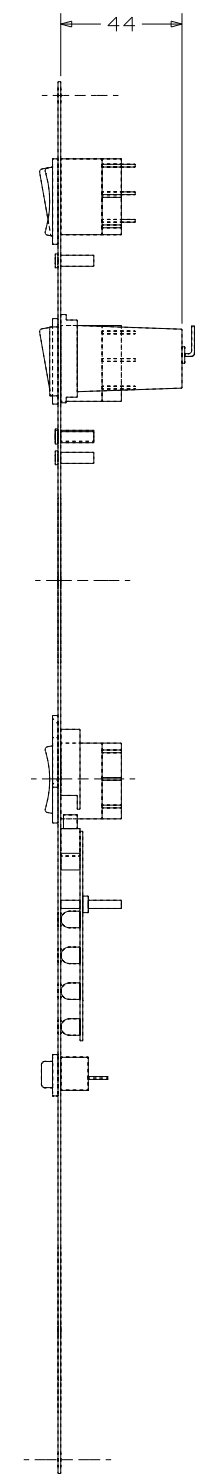

SEE CHART
FOR COLOR VARIATIONS
OF THIS PART

WINNEBAGO		COPYRIGHT 2005 WINNEBAGO INDUSTRIES, INC.	
DFTR	ORIG. DATE	ALL DIMENSIONS ARE IN MILLIMETERS	
CHKR		STANDARDS	
P.E.		FIRST USED	
M.E.		UNSPECIFIED TOLERANCES ARE:	
DSNR		MATERIAL:	
WHOLE DIM (X)		:	
ONE-PLACE (X.X)		:	
TWO-PLACE (X.XX)		:	
ANGLE		:	
THIRD ANGLE PROJECTION			
DO NOT SCALE DRAWING			
TITLE:		PANEL-MONITOR	
SHEET 1 of 7		PART NO 133004	
REF:		1 4/11/2005	

- PIN #
- 1. 16 RED GENERATOR METER (+)
 - 2. 16 YEL GENERATOR START
 - 3. 16 GRN GENERATOR STOP
 - 4. 16 BLK GENERATOR (-)

HOUSING-AMP
(UNIVERSAL MATE-N-LOK)
1-480702-0
CONTACT-PIN
350538-1

- PIN #
- 1. 14 BLK (HOUSE +12VDC)
 - 2. 14 (CHASSIS +12VDC)
 - 3. 14 WHT (GROUND)
 - 4. 20 RED (WATER TANK)
 - 5. 20 BRN (BLACK TANK)
 - 6. 20 GRN (GRAY TANK)
 - 7. 12 RED/WHT (REMOTE WATER PUMP SWITCH)
 - 8. 12 RED (WATER PUMP SWITCH)
 - 9. 12 WHT/RED (REMOTE WATER PUMP)
 - 10. BLANK
 - 11. BLANK
 - 12. 20 WHT/GRN (LP TANK SENSOR)
 - 13. 16 YEL (WATER HEATER IGNITION)
 - 14. BLANK
 - 15. 20 WHT/BLU (WATER HEATER INDICATOR)

HOUSING-AMP
(UNIVERSAL MATE-N-LOK)
1-480710-0
CONTACT-PIN
350538-1

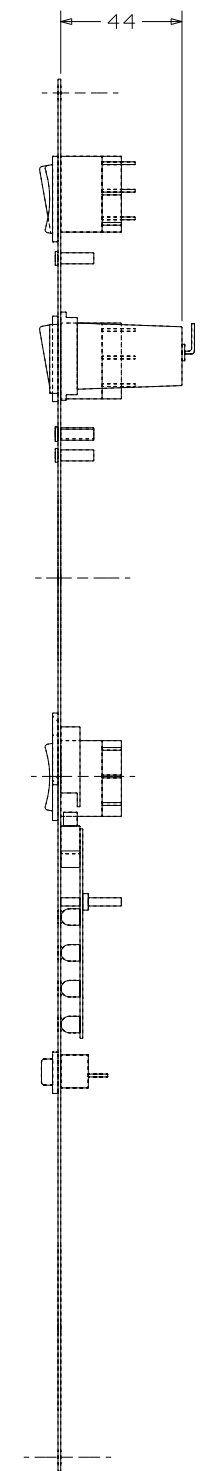
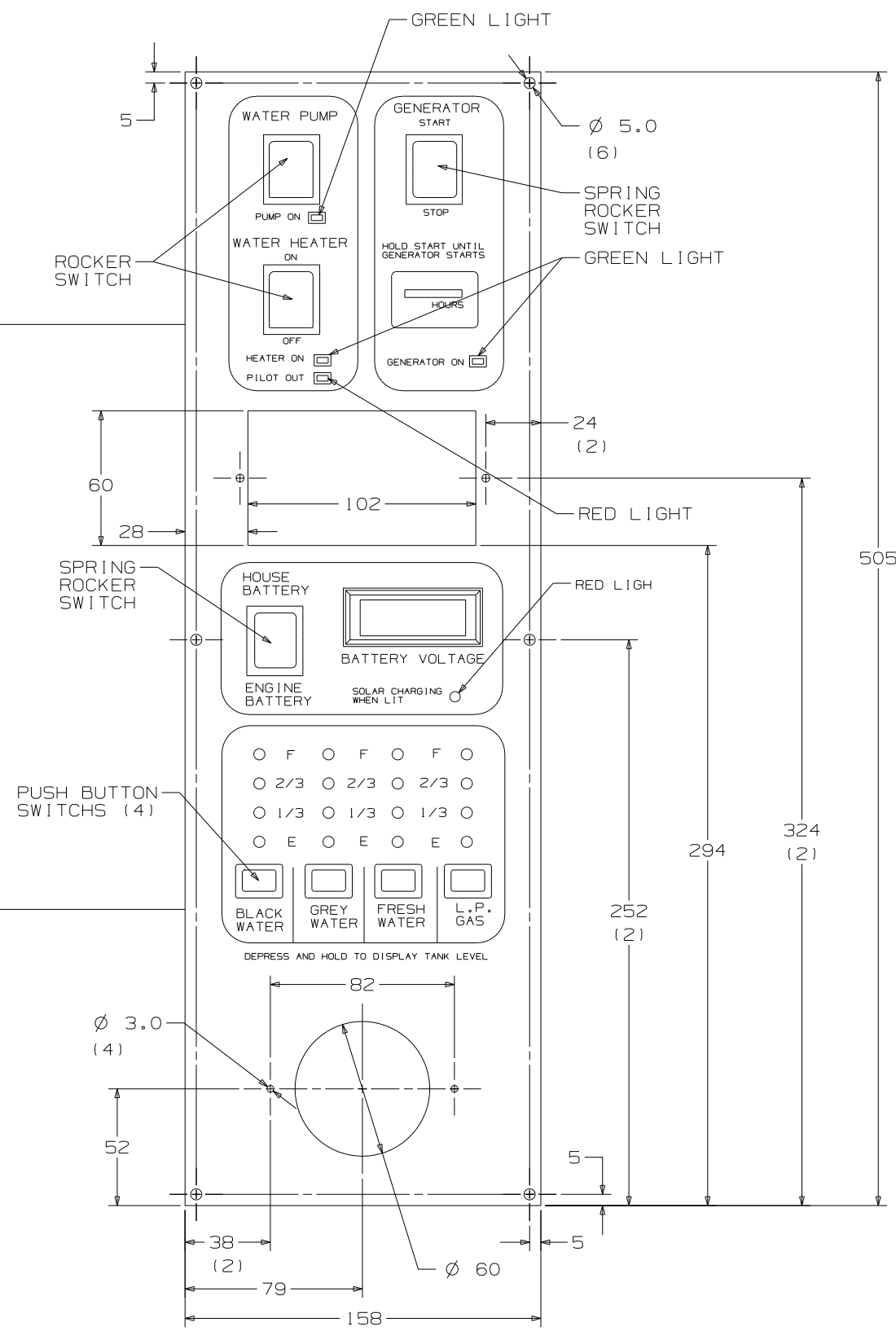

FIRST USED	STANDARDS
TITLE	DO NOT SCALE DRAWING
SHEET 2	PANEL - MONITOR
PART NO	133004

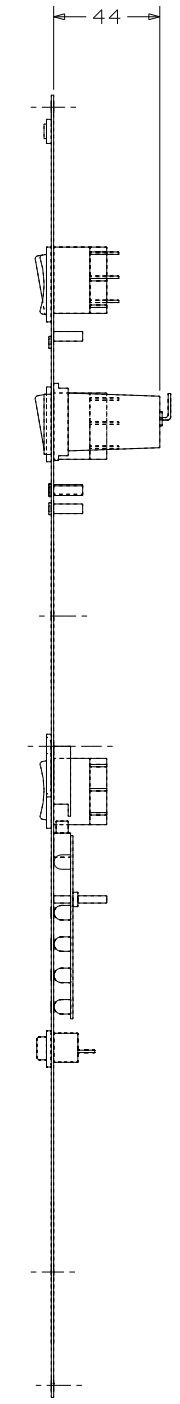
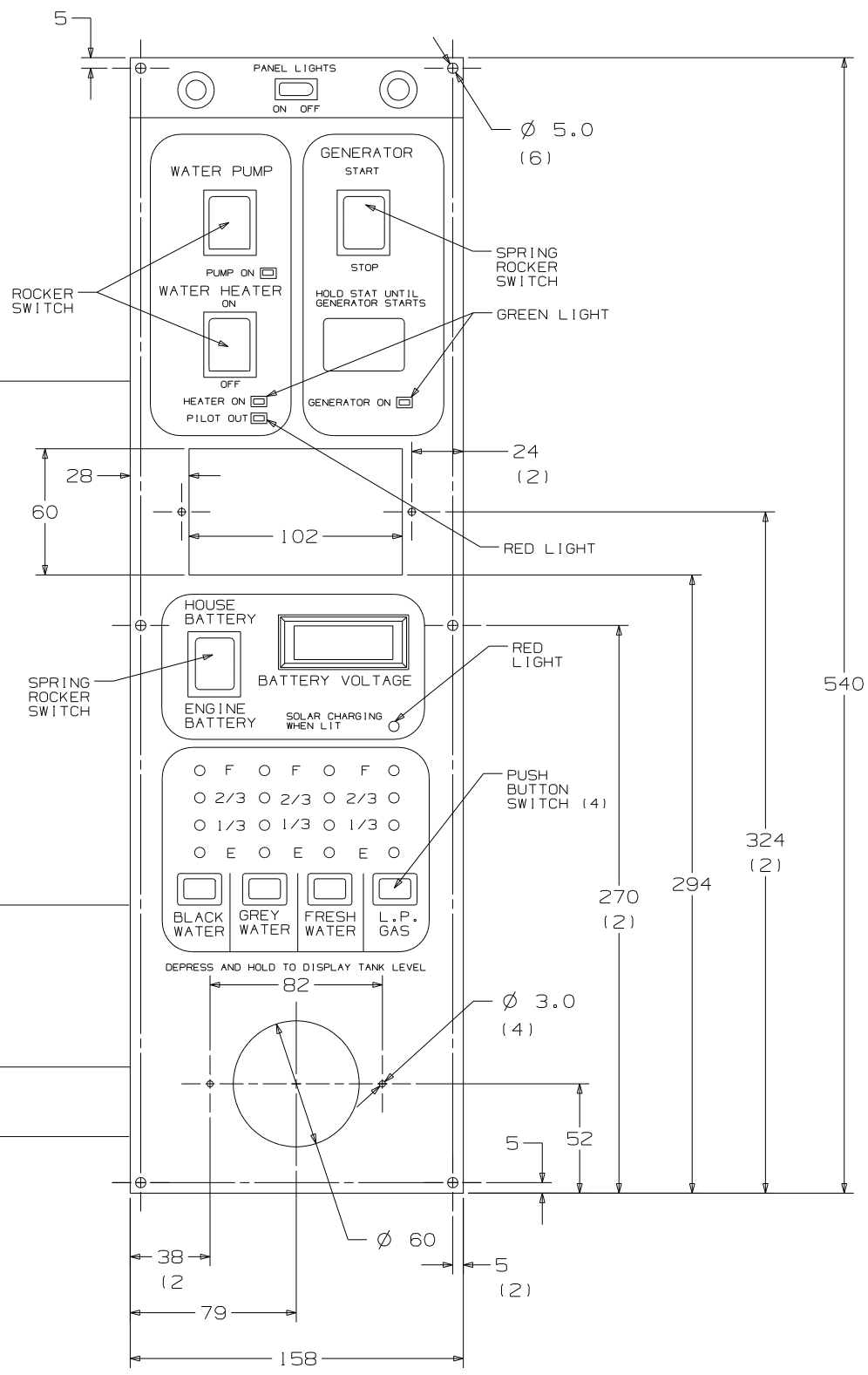
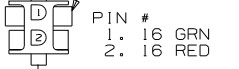
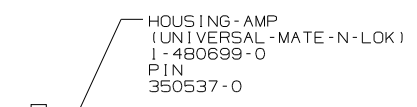
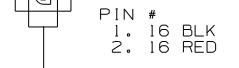
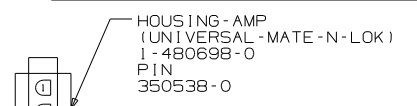
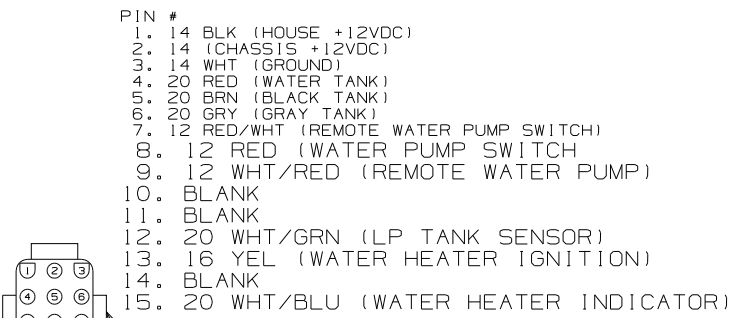
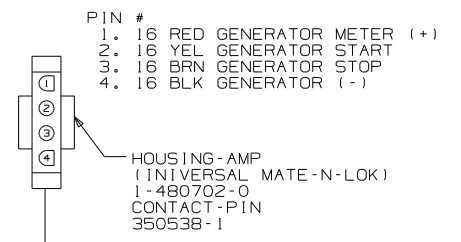

FIRST USED	STANDARD
TITLE	DO NOT SCALE DRAWING
TITLE	PANEL-MONITOR
SHEET 3	PART NO 133004

- PIN #
- 1. 16 RED GENERATOR METER (+)
 - 2. 16 YEL GENERATOR START
 - 3. 16 GRN GENERATOR STOP
 - 4. 16 BLK GENERATOR (-)

HOUSING-AMP
(UNIVERSAL MATE-N-LOK)
1-480702-0
CONTACT-PIN
350538-1

- PIN #
- 1. 14 BLK (HOUSE +12VDC)
 - 2. 14 (CHASSIS +12VDC)
 - 3. 14 WHT (GROUND)
 - 4. 20 RED (WATER TANK)
 - 5. 20 BRN (BLACK TANK)
 - 6. 20 GRN (GRAY TANK)
 - 7. 12 RED/WHT (REMOTE WATER PUMP SWITCH)
 - 8. 12 RED (WATER PUMP SWITCH)
 - 9. 12 WHT/RED (REMOTE WATER PUMP)
 - 10. BLANK
 - 11. BLANK
 - 12. 20 WHT/GRN (LP TANK SENSOR)
 - 13. BLANK
 - 14. BLANK
 - 15. BLANK

HOUSING-AMP
(UNIVERSAL MATE-N-LOK)
1-480710-0
CONTACT-PIN
350538-1

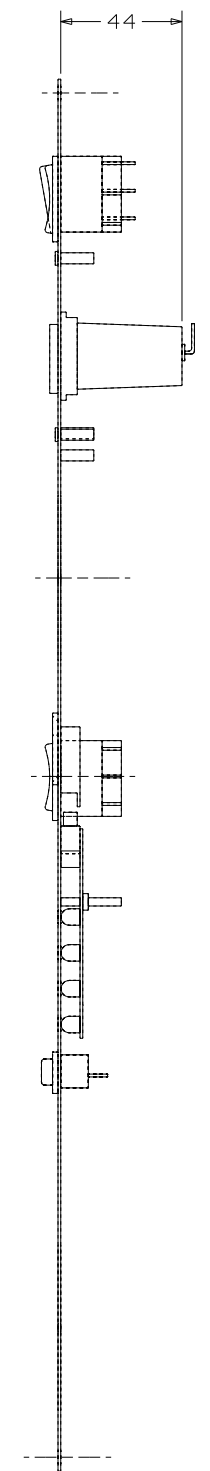
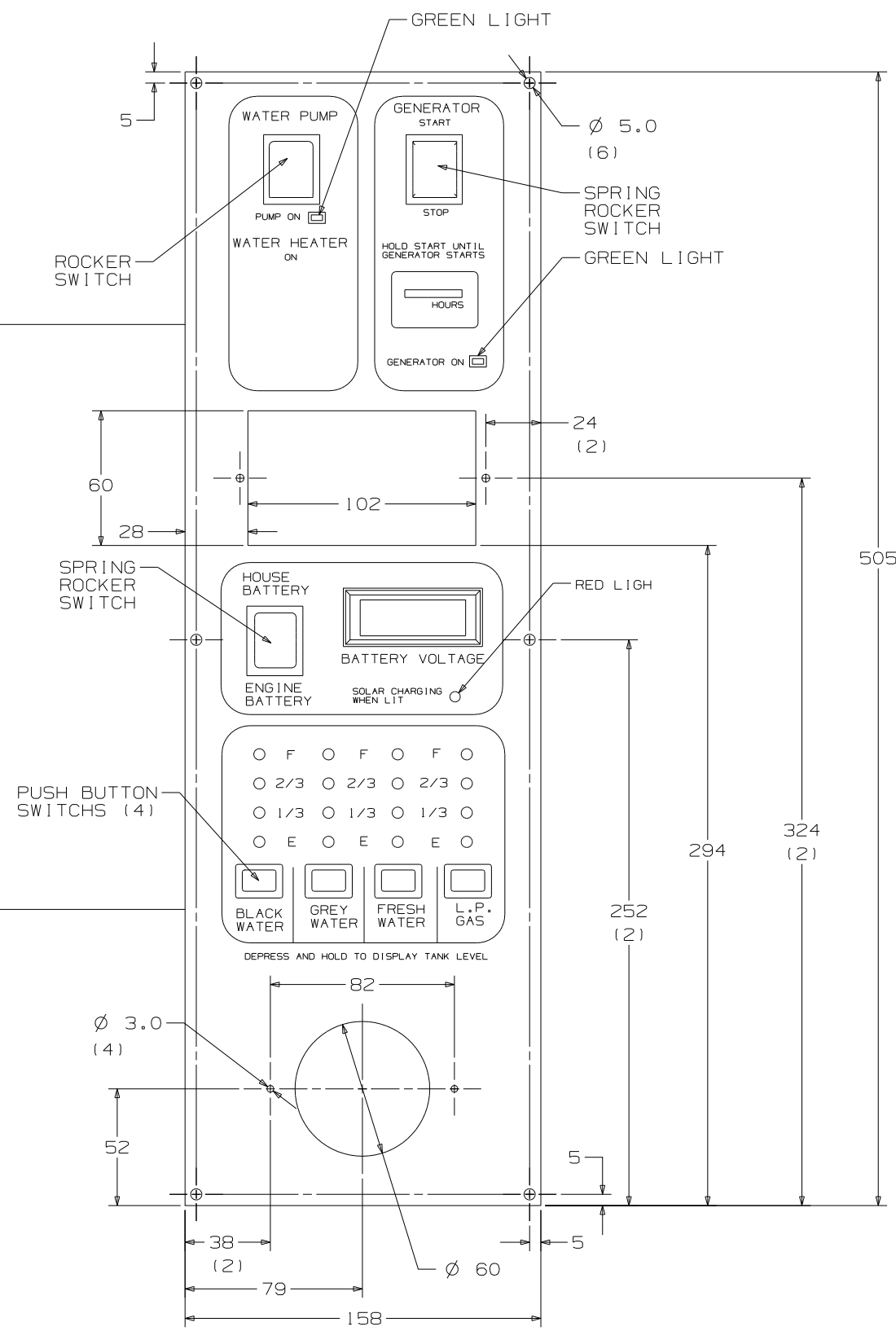

FIRST USED	STANDARDS
TITLE	DO NOT SCALE DRAWING
SHEET 4	PANEL - MONITOR
PART NO	133004

CONFIDENTIAL
 THIS DOCUMENT, INCLUDING ALL INFORMATION CONTAINED HEREIN IS THE EXCLUSIVE AND CONFIDENTIAL PROPERTY OF VENTLINE DIVISION OF TOMKINS INDUSTRIES INC. THE DOCUMENT AND INFORMATION ARE NOT TO BE COPIED, REPRODUCED OR DELIVERED TO OTHERS, IN WHOLE OR IN PART, WITHOUT THE EXPRESS WRITTEN PERMISSION OF VENTLINE. THE DOCUMENT IS TO BE RETURNED PROMPTLY TO VENTLINE AFTER HAVING SERVED THE PURPOSE FOR WHICH DELIVERED.
 ©1995 VENTLINE DIVISION, TOMKINS INDUSTRIES, INC.
 All Rights Reserved, including the right to reproduce this document or any part thereof

LTR.	DESCRIPTION	DATE	CHK. BY	APP. BY
A	SEE PAGE 3 ECN 16381	ECN 16261	4-6-04	R.L. R.L.
B	L5130-02 WAS L5113-04	ECN 16394	4-21-04	R.L. R.L.

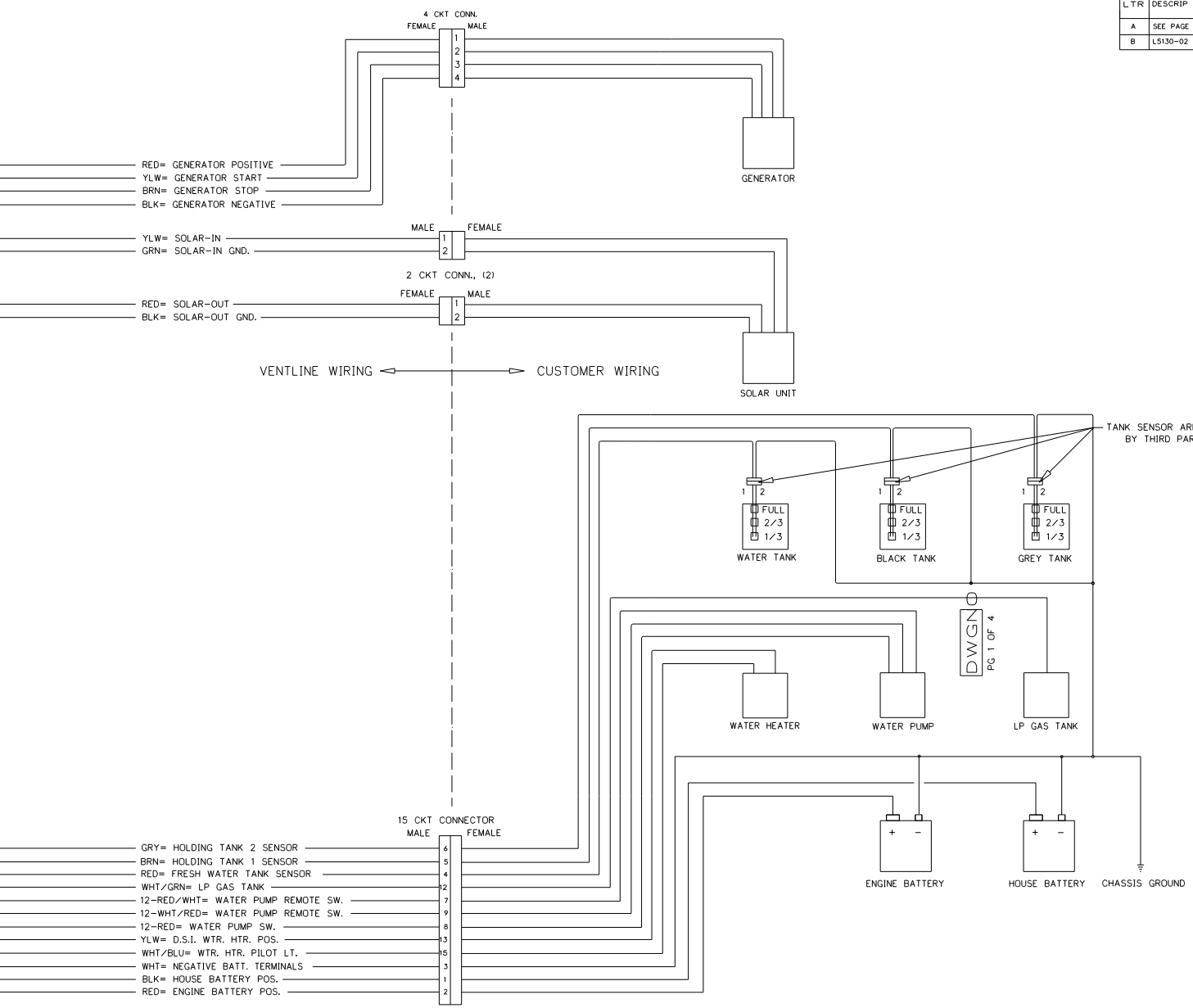
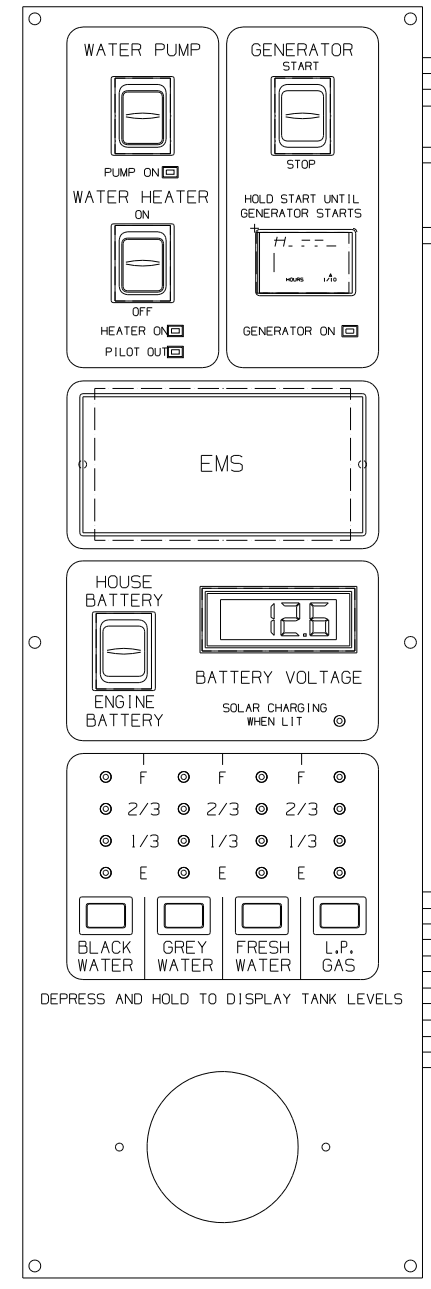

- NOTES:
- UNLESS OTHERWISE SPECIFIED ALL WIRE IS 22 AWG.
 - REF. DWG.'S:
 HARNESS, INTERNAL & SWITCH= L7785-01, -02
 HARNESS, GEN. INTERNAL & SWITCH= L7786-00
 HARNESS, SOLAR LIGHT= L7722-00
 PCB= L5130-02
 HARNESS, TEST= L8012-00
 TEST BOX= L8506-00
 - ALL PIGTAILS TO BE SUPPLIED BY CUSTOMER.
 - BEFORE PACKING, SECURE HARNESS WITH V00169-00 TIE WRAP ON RIGHT SIDE POST.

ENGLISH TOLERANCE UNLESS SPECIFIED:
 0 PL.: .040
 2 PL.: .010
 1 PL.: .020
 3 PL.: .005
 FRACTIONS ±1/64

PART NO.	REV'D	MATERIAL	DESCRIPTION	DWG SIZE
BLANK		BLANK	WGT	USED
DRWN DATE		MATERIAL	USED ON	
DRWN DATE		MATL	MATL	
CHECKED DATE		NAME	SCALE	
CHECKED DATE		DWGNAME	DWG. NO. PG 1 OF 4	
APPV'D DATE		DWGNAME	DWGNO	

FIRST USED	STANDARD
TITLE	DO NOT SCALE DRAWING
TITLE	PANEL - MONITOR
SHEET 5	PART NO 133004

CONFIDENTIAL
 THIS DOCUMENT, INCLUDING ALL INFORMATION CONTAINED HEREIN IS THE EXCLUSIVE
 AND CONFIDENTIAL PROPERTY OF VENTLINE DIVISION OF TOMING INDUSTRIES, INC.
 THE DOCUMENT AND INFORMATION HEREIN NOT TO BE COPIED, REPRODUCED OR DELIVERED
 TO OTHERS, IN WHOLE OR IN PART, WITHOUT THE EXPRESS WRITTEN PERMISSION OF
 VENTLINE. THE DOCUMENT IS TO BE RETURNED PROMPTLY TO VENTLINE AFTER HAVING
 SERVED THE PURPOSE FOR WHICH DELIVERED.
 ©1995 VENTLINE DIVISION, TOMING INDUSTRIES, INC.
 All Rights Reserved, including the right to reproduce this document in any part thereof.

LTR.	DESCRIPTION	DATE	CHK'D	APP'D
A	SEE PAGE 3 ECN 16381	4-6-04	RUL	RUL
B	LS130-02 WAS LS113-04 ECN 16394	4-21-04	RUL	RUL

DETAIL - A

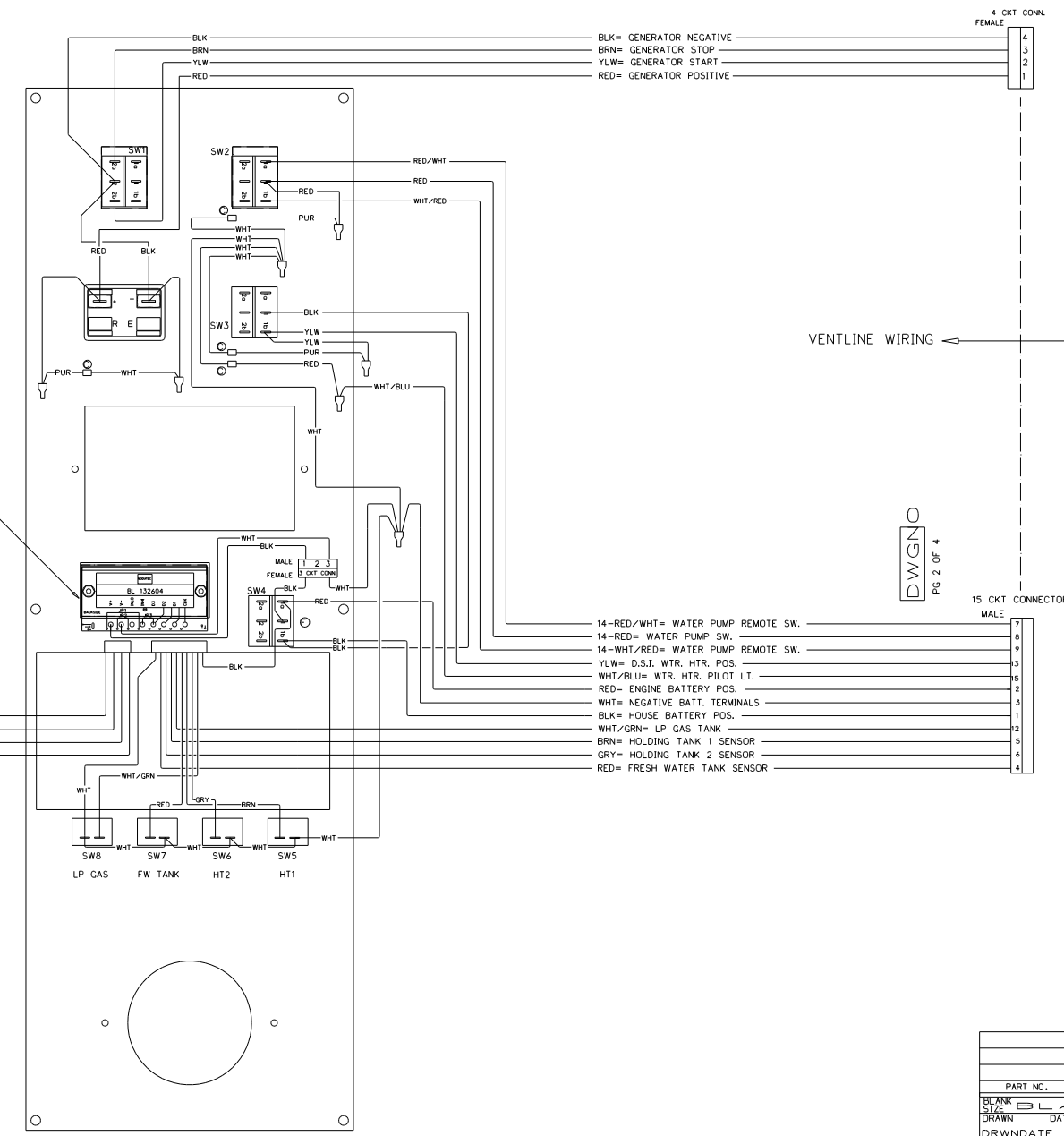
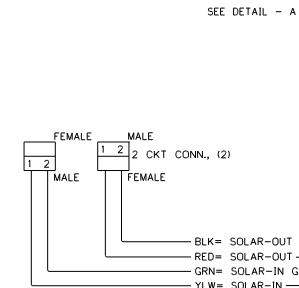
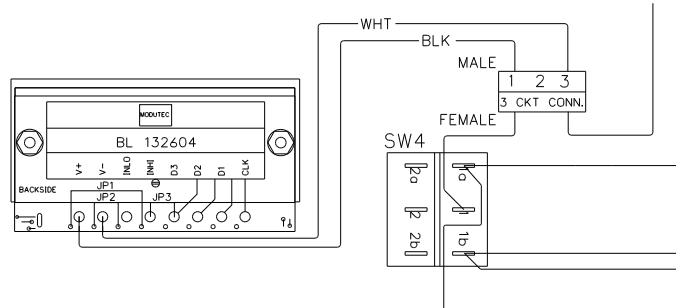

DWG NO
 PG 2 OF 4

- NOTES:
- UNLESS OTHERWISE SPECIFIED ALL WIRE IS 22 AWG.
 - REF. DWG.'S:
 HARNESS, INTERNAL & SWITCH= L7785-01, -02
 HARNESS, GEN. INTERNAL & SWITCH= L7786-00
 HARNESS, SOLAR LIGHT= L7722-00
 PCB= LS130-02
 HARNESS, TEST= L8012-00
 TEST BOX= L8506-00
 - ALL PIGTAILS TO BE SUPPLIED BY CUSTOMER.
 - BEFORE PACKING, SECURE HARNESS WITH V00167-00 TIE WRAP ON RIGHT SIDE POST.

ENGLISH (TOLERANCE UNLESS SPECIFIED)
 0 PL.: .040 1 PL.: .020
 2 PL.: .010 3 PL.: .005
 FRACTIONS: 1/64

PART NO.	REV'D	MATERIAL	DESCRIPTION	DWG SIZE
BLANK SIZE		BLANK	WGT USED	USED ON
DRAWN	DATE	MATERIAL	MATL	MATL
DRWN DATE	DATE	MATL	MATL	
CHECKED	DATE			
CHECKED DATE	DATE			
APPV'D	DATE			

FIRST USED	STANDARD
TITLE	DO NOT SCALE DRAWING
TITLE	PANEL - MONITOR
SHEET 7	PART NO 133004