

9. SECURE PIPES TO CABINET USING WIRE TIE 108046-02-000 AND SCREW G67-10-12U (8).
8. VENT PIPE MUST PROJECT 51 MIN TO 64 MAX ABOVE ROOF FOR PROPER FIT AND FUNCTION.
7. SEE DWG 61607-01-000 FOR INSTL OF GROMMET.
6. SEAL ALL AROUND SHOWER PAN.
5. FOR CANADIAN UNITS EACH HOLDING TANK SHALL HAVE A CSA APPROVAL STAMPED NEAR THE IAPMO APPROVAL.
4. ALL EXTERIOR OPENINGS AROUND PIPE TO BE SEALED WITH 110744-01-000.
3. ALL PIPE AND FITTINGS TO BE ASSEMBLED WITH SOLVENT 4020-01-000.
2. SLOPE OF TRAP MUST BE 6 PER 300 MINIMUM.
1. SLOPE OF HORIZONTAL PIPING TO BE 6 PER 300 MINIMUM.

44E COUNTERTOP-SOL. SURFACE-GALLEY
 WIN WINNEBAGO ONLY
 ITA ITASCA ONLY

WINNEBAGO O1 G35U

QTY	DATE	UNSPECIFIED TOLERANCES ARE:	MATERIAL
CHP	DATE	WHOLE DIM (IN)	
FPE	DATE	ONE-PLACE (IN.XI)	
FVE	DATE	TWO-PLACE (IN.XX)	
CDR	DATE	ANGLE	
	DATE	THIRD ANGLE PERSPECTIVE	

FOR DRAINAGE CALL-OUTS SEE DWG NO. 116229-01-000

SINK-SST,DOUBLE
 110654-01-000 (US/CAN)
 STRAINER
 92303-01-000 (2)
 SEAL
 91255-02-000 (A/R)
 RETAINER
 83125-02-000(2)
 77351-30-000
 77351-32-000(3)

44E

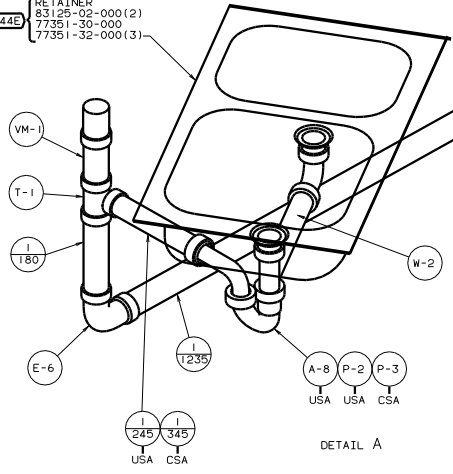

DETAIL A

SINK-LAVATORY
 105921-01-CHT
 SEAL
 91255-02-000 (A/R)

STRAINER
 106116-01-CHT

P-3 P-2 A-8
 CSA USA USA
 I 200 I 100
 CSA USA

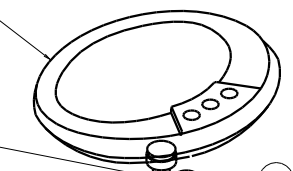

DETAIL B

SHOWER INSTL-ENCLOSURE
 132496-01-000
 DRAIN
 132150-01-CHT
 SEALER
 69640-01-000
 NUT
 130403-01-000
 TAILPIECE
 11069-06-000
 WASHER
 127440-02-CHT

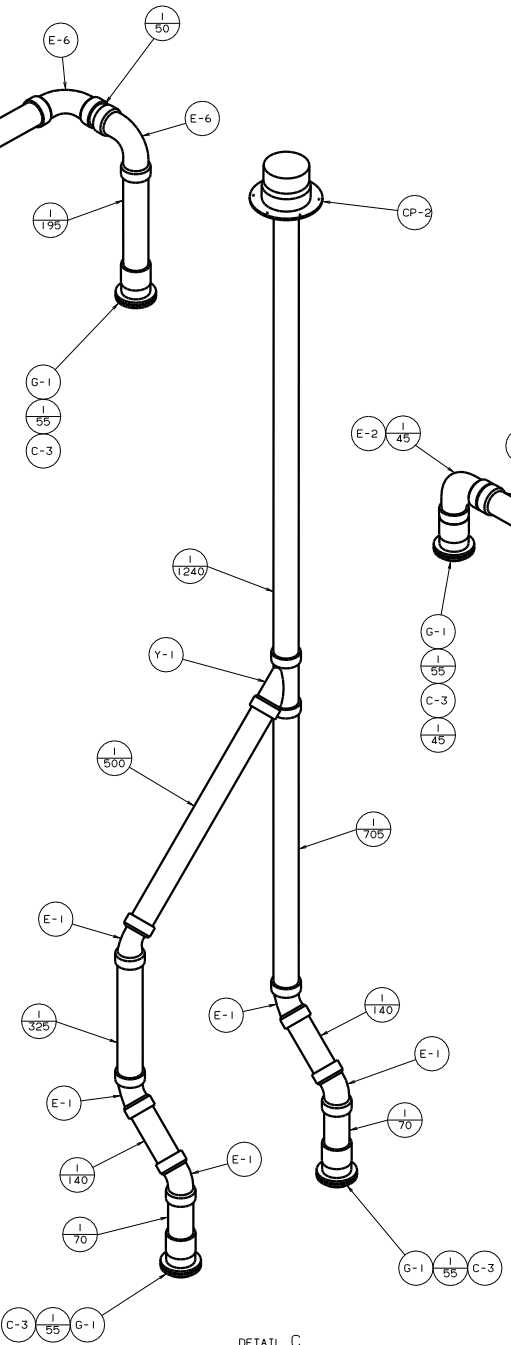

DETAIL C

TOILET-AURORA
 132389-01-CHT
 134789-01-CHT

1YA
 WIN

F-7
 SCREW
 87721-01-000 (8)

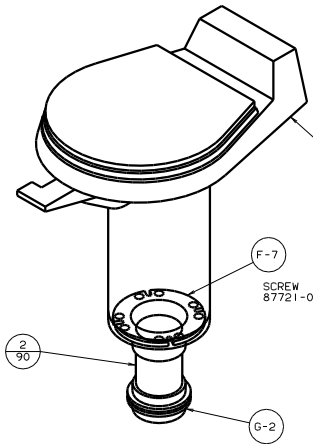

DETAIL D

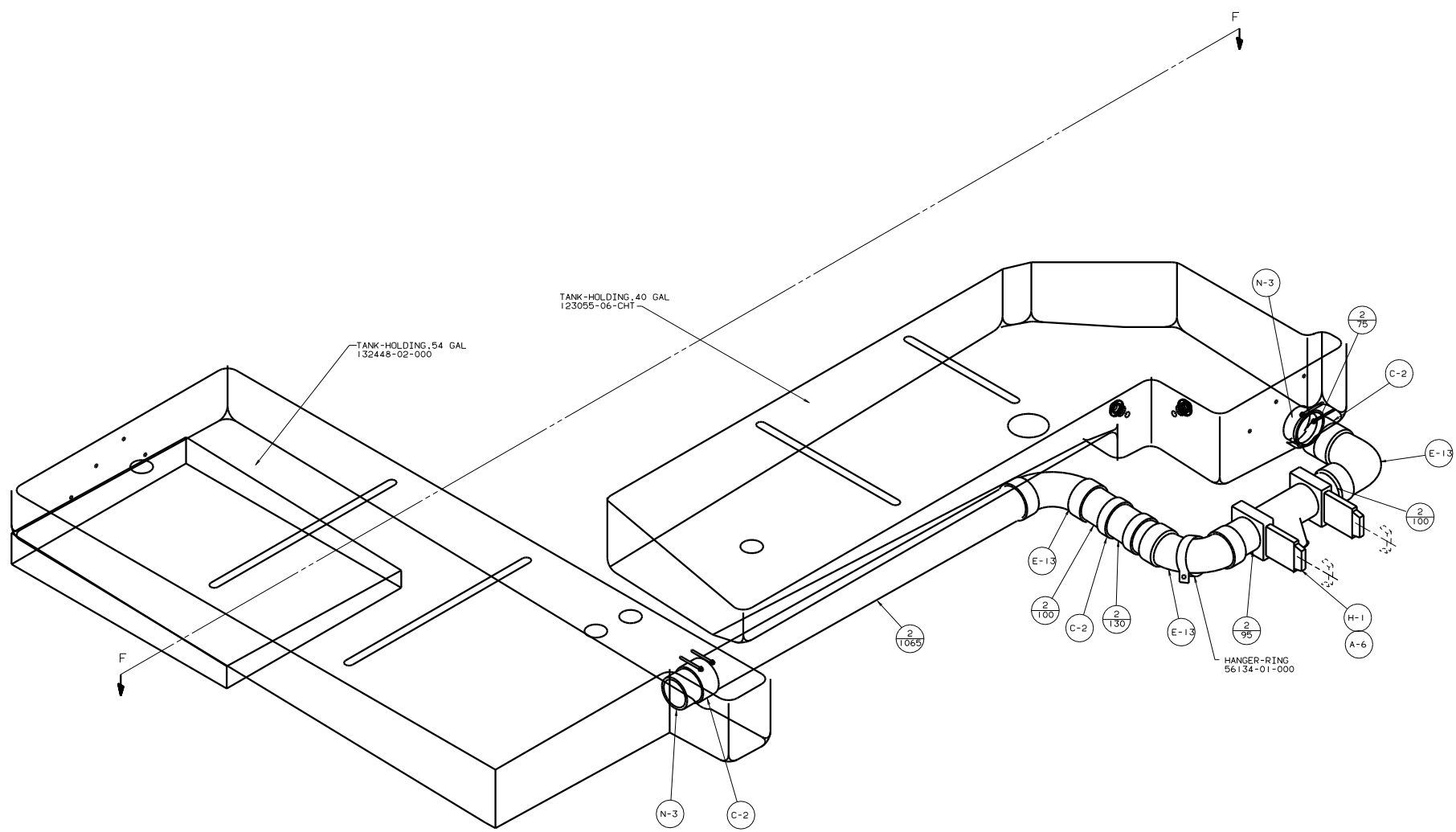

DETAIL E

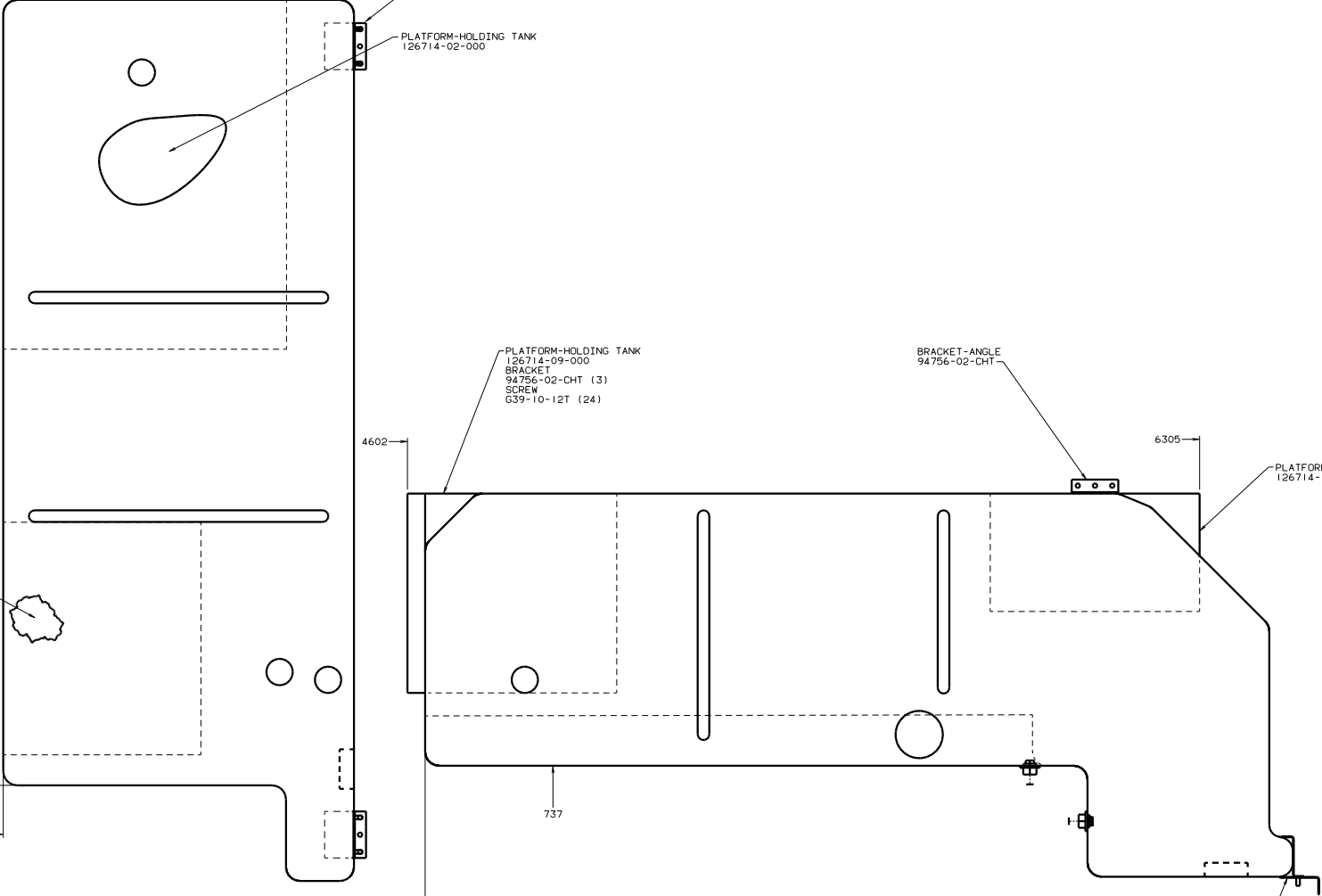

VIEW F-F

1. ALL DIMENSIONS ARE FROM FRONT AND LEFT SIDE OF UPPER FLOOR
(700.1222 FROM CENTERLINE FRONT AXLE.)

NOTES:

01 G35U

TITLE: DRAINAGE SYSTEM INSTL	
30 THE BUCK BUILDING	1/E
SHEET 4 OF 4	135053

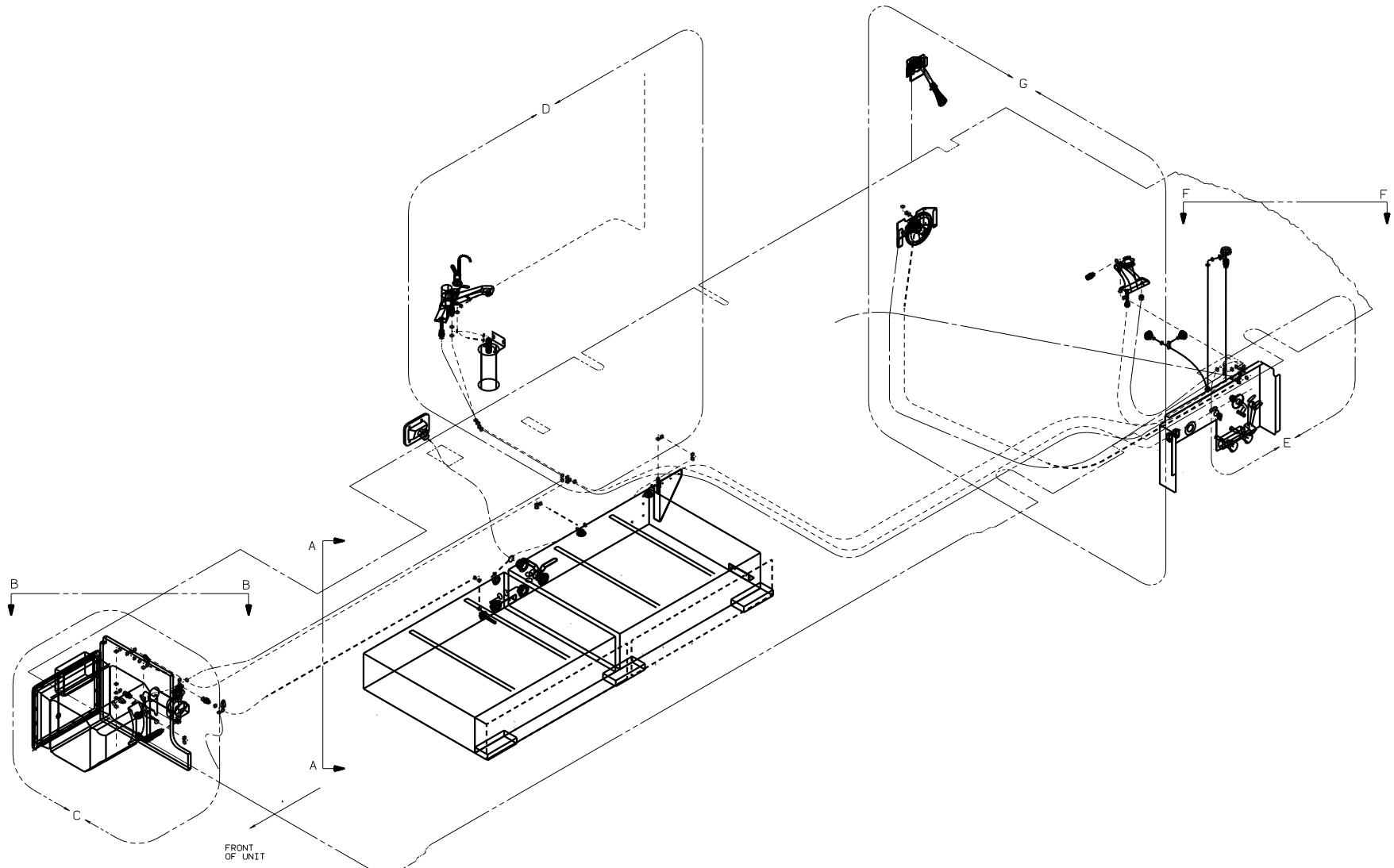

- 8. APPLY DECAL INSIDE OF UPPER SHOWER HEAD HOLDER TO RETAIN HAND SHOWER UNIT INSIDE HOLDER.
 - 7. PRE-DRILL SHOWER SURROUND WITH 5.0 DIA HOLES USING MOUNTING BRACKET AS A TEMPLATE.
 - 6. ADD TEFLON TAPE 10405-02-000 TO FITTING.
 - 5. USE DETAIL "J" IN THIS AREA (BOTH ENDS OF TUBING).
 - 4. FLUSHING SYSTEM REQUIRES 125697-06-000 INSTRUCTION SHEET.
3. ALL TUBING TO BE SECURED AT 1200 INTERVALS MAX WITH CLAMP 10495-01-000 OR CLIP 91951-01-000 AND SCREW G67-10-12B.
2. TUBING TO BE INSTALLED WITH SUFFICIENT SLOPE TO PROVIDE DRAINAGE TO THE NEAREST VALVE.
1. PLASTIC FITTINGS TO BE SEALED WITH SEALANT 84456-01-000.

- (43H) SHOWER HEAD-HAND HELD
- (WIN) WINNEBAGO ONLY
- (TIA) ITASCA ONLY
- (29B) WATER PURIFIER
- (15U) REFRIGERATOR/FRZR W/ICEMAKER

(X-X) FOR WATER CALLOUTS SEE DWG NO. 116230-01-000

LEGEND	
HOT	●●●●●
COLD	●●●●●

		01 G35U	
		DATE	
DATE	UNDESIGNED TOLERANCES ARE:	MATERIAL	
DATE	WHOLE DIM (IN)	F	
DATE	ONE-PLACE (IN.X1)	F	
DATE	TWO-PLACE (IN.XX)	F	
DATE	THREE-PLACE (IN.XXX)	F	
DATE	FOUR-PLACE (IN.XXXX)	F	
DATE	FIVE-PLACE (IN.XXXXX)	F	
DATE	SIX-PLACE (IN.XXXXXX)	F	
DATE	SEVEN-PLACE (IN.XXXXXXX)	F	
DATE	EIGHT-PLACE (IN.XXXXXXX)	F	
DATE	NINE-PLACE (IN.XXXXXXX)	F	
DATE	TEN-PLACE (IN.XXXXXXX)	F	
DATE	ELEVEN-PLACE (IN.XXXXXXX)	F	
DATE	TWELVE-PLACE (IN.XXXXXXX)	F	
DATE	THIRTEEN-PLACE (IN.XXXXXXX)	F	
DATE	FOURTEEN-PLACE (IN.XXXXXXX)	F	
DATE	FIFTEEN-PLACE (IN.XXXXXXX)	F	
DATE	SIXTEEN-PLACE (IN.XXXXXXX)	F	
DATE	SEVENTEEN-PLACE (IN.XXXXXXX)	F	
DATE	EIGHTEEN-PLACE (IN.XXXXXXX)	F	
DATE	NINETEEN-PLACE (IN.XXXXXXX)	F	
DATE	TWENTY-PLACE (IN.XXXXXXX)	F	
DATE	TWENTY-ONE-PLACE (IN.XXXXXXX)	F	
DATE	TWENTY-TWO-PLACE (IN.XXXXXXX)	F	
DATE	TWENTY-THREE-PLACE (IN.XXXXXXX)	F	
DATE	TWENTY-FOUR-PLACE (IN.XXXXXXX)	F	
DATE	TWENTY-FIVE-PLACE (IN.XXXXXXX)	F	
DATE	TWENTY-SIX-PLACE (IN.XXXXXXX)	F	
DATE	TWENTY-SEVEN-PLACE (IN.XXXXXXX)	F	
DATE	TWENTY-EIGHT-PLACE (IN.XXXXXXX)	F	
DATE	TWENTY-NINE-PLACE (IN.XXXXXXX)	F	
DATE	THIRTY-PLACE (IN.XXXXXXX)	F	
DATE	THIRTY-ONE-PLACE (IN.XXXXXXX)	F	
DATE	THIRTY-TWO-PLACE (IN.XXXXXXX)	F	
DATE	THIRTY-THREE-PLACE (IN.XXXXXXX)	F	
DATE	THIRTY-FOUR-PLACE (IN.XXXXXXX)	F	
DATE	THIRTY-FIVE-PLACE (IN.XXXXXXX)	F	
DATE	THIRTY-SIX-PLACE (IN.XXXXXXX)	F	
DATE	THIRTY-SEVEN-PLACE (IN.XXXXXXX)	F	
DATE	THIRTY-EIGHT-PLACE (IN.XXXXXXX)	F	
DATE	THIRTY-NINE-PLACE (IN.XXXXXXX)	F	
DATE	FOURTY-PLACE (IN.XXXXXXX)	F	
DATE	FOURTY-ONE-PLACE (IN.XXXXXXX)	F	
DATE	FOURTY-TWO-PLACE (IN.XXXXXXX)	F	
DATE	FOURTY-THREE-PLACE (IN.XXXXXXX)	F	
DATE	FOURTY-FOUR-PLACE (IN.XXXXXXX)	F	
DATE	FOURTY-FIVE-PLACE (IN.XXXXXXX)	F	
DATE	FOURTY-SIX-PLACE (IN.XXXXXXX)	F	
DATE	FOURTY-SEVEN-PLACE (IN.XXXXXXX)	F	
DATE	FOURTY-EIGHT-PLACE (IN.XXXXXXX)	F	
DATE	FOURTY-NINE-PLACE (IN.XXXXXXX)	F	
DATE	FIFTY-PLACE (IN.XXXXXXX)	F	
DATE	FIFTY-ONE-PLACE (IN.XXXXXXX)	F	
DATE	FIFTY-TWO-PLACE (IN.XXXXXXX)	F	
DATE	FIFTY-THREE-PLACE (IN.XXXXXXX)	F	
DATE	FIFTY-FOUR-PLACE (IN.XXXXXXX)	F	
DATE	FIFTY-FIVE-PLACE (IN.XXXXXXX)	F	
DATE	FIFTY-SIX-PLACE (IN.XXXXXXX)	F	
DATE	FIFTY-SEVEN-PLACE (IN.XXXXXXX)	F	
DATE	FIFTY-EIGHT-PLACE (IN.XXXXXXX)	F	
DATE	FIFTY-NINE-PLACE (IN.XXXXXXX)	F	
DATE	SIXTY-PLACE (IN.XXXXXXX)	F	
DATE	SIXTY-ONE-PLACE (IN.XXXXXXX)	F	
DATE	SIXTY-TWO-PLACE (IN.XXXXXXX)	F	
DATE	SIXTY-THREE-PLACE (IN.XXXXXXX)	F	
DATE	SIXTY-FOUR-PLACE (IN.XXXXXXX)	F	
DATE	SIXTY-FIVE-PLACE (IN.XXXXXXX)	F	
DATE	SIXTY-SIX-PLACE (IN.XXXXXXX)	F	
DATE	SIXTY-SEVEN-PLACE (IN.XXXXXXX)	F	
DATE	SIXTY-EIGHT-PLACE (IN.XXXXXXX)	F	
DATE	SIXTY-NINE-PLACE (IN.XXXXXXX)	F	
DATE	SEVENTY-PLACE (IN.XXXXXXX)	F	
DATE	SEVENTY-ONE-PLACE (IN.XXXXXXX)	F	
DATE	SEVENTY-TWO-PLACE (IN.XXXXXXX)	F	
DATE	SEVENTY-THREE-PLACE (IN.XXXXXXX)	F	
DATE	SEVENTY-FOUR-PLACE (IN.XXXXXXX)	F	
DATE	SEVENTY-FIVE-PLACE (IN.XXXXXXX)	F	
DATE	SEVENTY-SIX-PLACE (IN.XXXXXXX)	F	
DATE	SEVENTY-SEVEN-PLACE (IN.XXXXXXX)	F	
DATE	SEVENTY-EIGHT-PLACE (IN.XXXXXXX)	F	
DATE	SEVENTY-NINE-PLACE (IN.XXXXXXX)	F	
DATE	EIGHTY-PLACE (IN.XXXXXXX)	F	
DATE	EIGHTY-ONE-PLACE (IN.XXXXXXX)	F	
DATE	EIGHTY-TWO-PLACE (IN.XXXXXXX)	F	
DATE	EIGHTY-THREE-PLACE (IN.XXXXXXX)	F	
DATE	EIGHTY-FOUR-PLACE (IN.XXXXXXX)	F	
DATE	EIGHTY-FIVE-PLACE (IN.XXXXXXX)	F	
DATE	EIGHTY-SIX-PLACE (IN.XXXXXXX)	F	
DATE	EIGHTY-SEVEN-PLACE (IN.XXXXXXX)	F	
DATE	EIGHTY-EIGHT-PLACE (IN.XXXXXXX)	F	
DATE	EIGHTY-NINE-PLACE (IN.XXXXXXX)	F	
DATE	NINETY-PLACE (IN.XXXXXXX)	F	
DATE	NINETY-ONE-PLACE (IN.XXXXXXX)	F	
DATE	NINETY-TWO-PLACE (IN.XXXXXXX)	F	
DATE	NINETY-THREE-PLACE (IN.XXXXXXX)	F	
DATE	NINETY-FOUR-PLACE (IN.XXXXXXX)	F	
DATE	NINETY-FIVE-PLACE (IN.XXXXXXX)	F	
DATE	NINETY-SIX-PLACE (IN.XXXXXXX)	F	
DATE	NINETY-SEVEN-PLACE (IN.XXXXXXX)	F	
DATE	NINETY-EIGHT-PLACE (IN.XXXXXXX)	F	
DATE	NINETY-NINE-PLACE (IN.XXXXXXX)	F	
DATE	HUNDRED-PLACE (IN.XXXXXXX)	F	

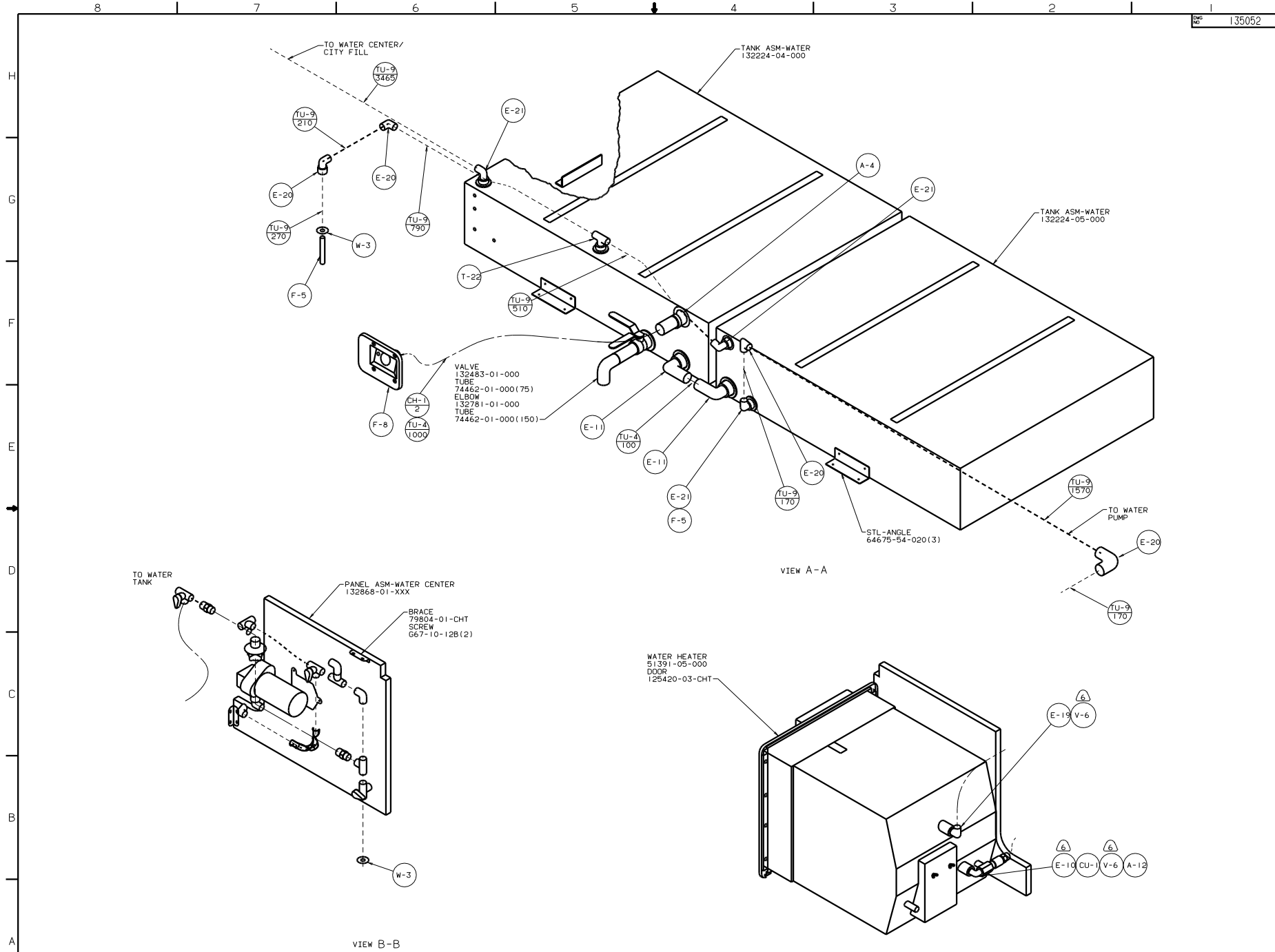

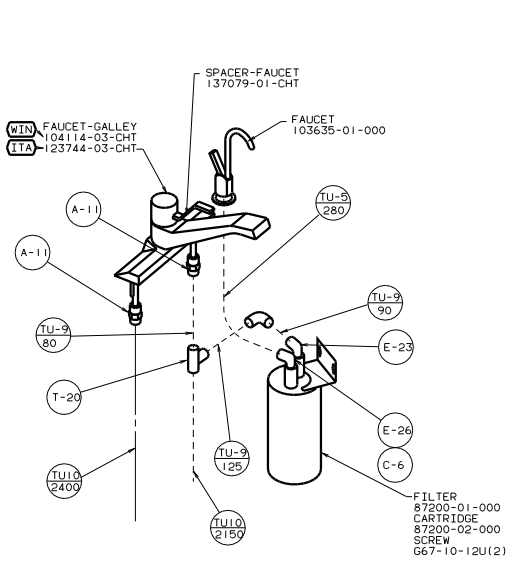

DETAIL D (29B)

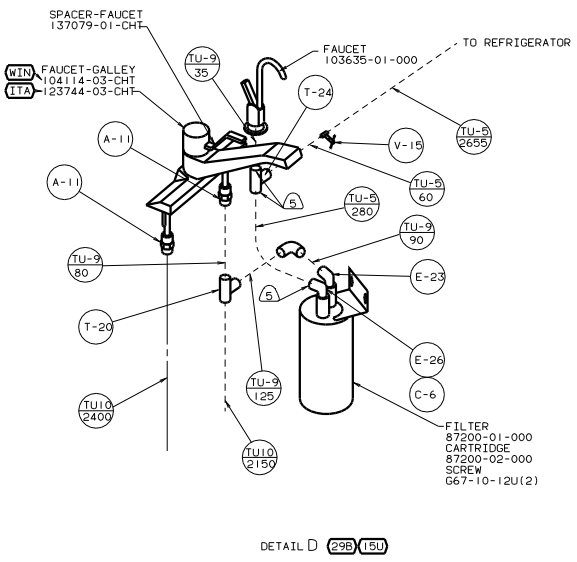

DETAIL D (29B) (15U)

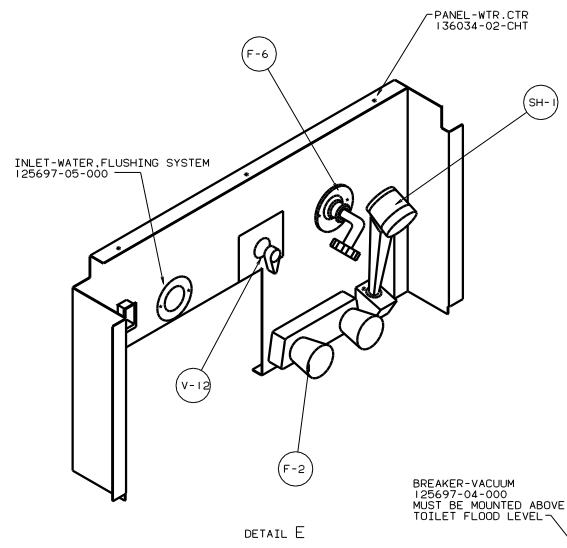

DETAIL E

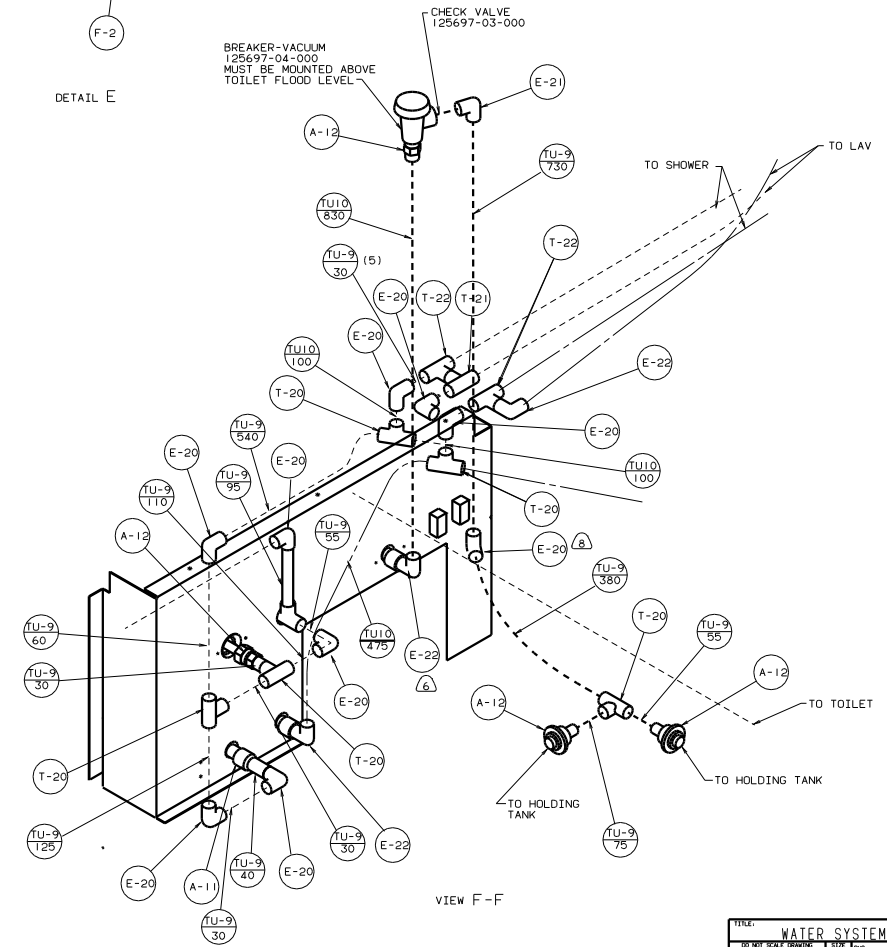

VIEW F-F

01 G35U

