



**DANGER**

**Danger of electrical shock, burns or death.** Always remove all power sources before attempting any repair, service or diagnostic work. Power can be present from shore power, generator, inverter or battery. All power sources must be disabled and secured before performing any service.



**CAUTION**

If you lack the skills, tools or equipment to perform diagnostic or repair work leave such work to an authorized Winnebago Industries dealer or other qualified shop.

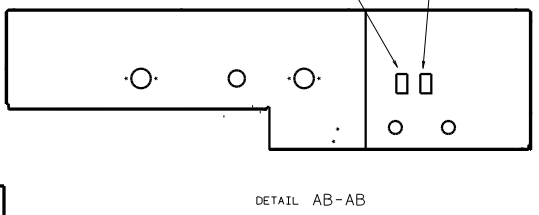
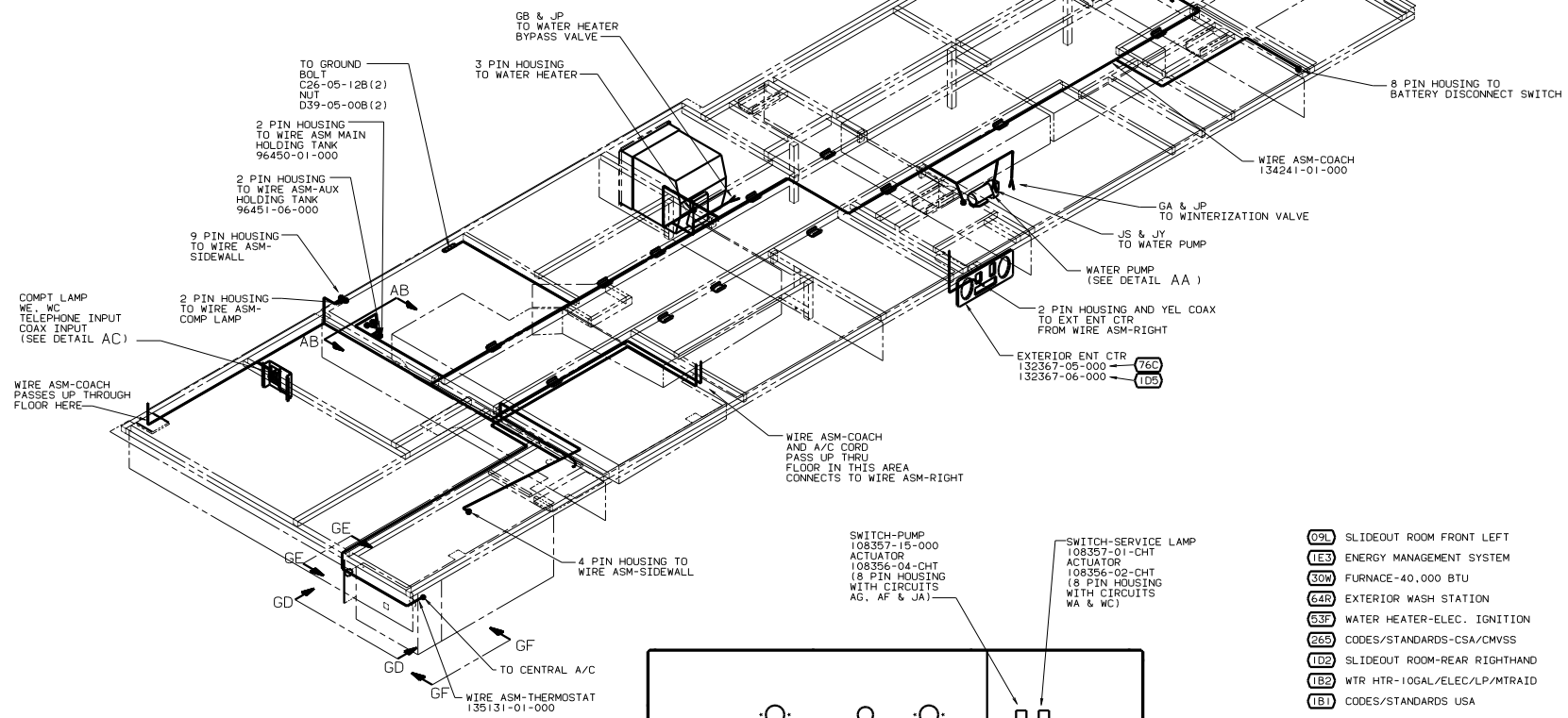
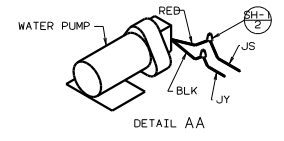
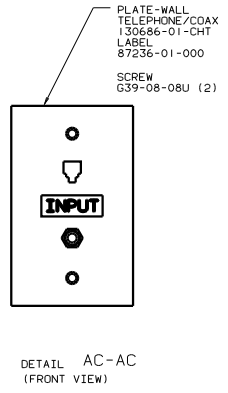
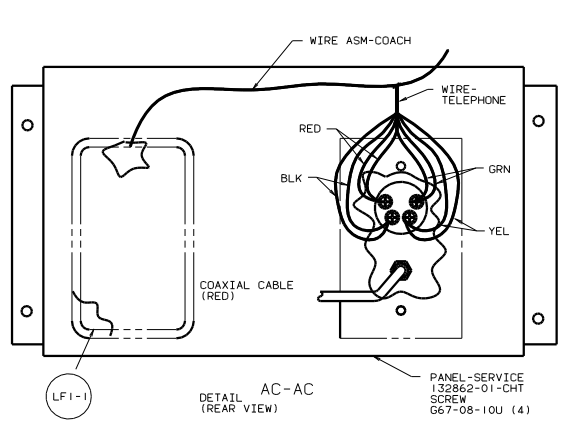

- (09L) SLIDEOUT ROOM FRONT LEFT
- (1E3) ENERGY MANAGEMENT SYSTEM
- (30W) FURNACE-40,000 BTU
- (64R) EXTERIOR WASH STATION
- (53F) WATER HEATER-ELEC. IGNITION
- (26S) CODES/STANDARDS-CSA/CMVSS
- (1D2) SLIDEOUT ROOM-REAR RIGHTHAND
- (1B2) WTR HTR-10GAL/ELEC/LP/MTRAUD
- (1B1) CODES/STANDARDS USA

1. ALL WIRE TO BE CLAMPED WITH CLAMP 10495-01-000 OR CLIP 80734-02-000 EVERY 600. USE SCREW G67-10-12B UNLESS OTHERWISE SPECIFIED.
2. CLAMP TO FLOOR SUPPORT TUBES AS NECESSARY WITH CLAMP 10497-01-000
3. WIRES THAT REST ON WIRE TRAYS ARE TO BE TIED DOWN WITH WIRE TIE 8343-02-000
4. SEE WIRING DIAGRAM-BODY FOR ADDITIONAL INFORMATION.
5. WIRE TO BE ROUTED DOWN THROUGH HOLE FORWARD OF RISER TO EXTERIOR ENTERTAINMENT CENTER.

FOR ELECTRICAL TORQUE SPECIFICATIONS SEE DWG NO. 128783-01-000

FOR ELECTRICAL CALLOUTS SEE DWG NO. 121339-01-000

WINNEBAGO OO L36W

DATE	UNSPECIFIED TOLERANCES ARE:	MATERIAL
DATE	WHOLE DIM (1)	
DATE	ONE-PLACE (1/32)	
DATE	TWO-PLACE (1/64)	
DATE	THREE-PLACE (1/128)	
DATE	FOUR-PLACE (1/256)	
DATE	FIVE-PLACE (1/512)	
DATE	SIX-PLACE (1/1024)	
DATE	SEVEN-PLACE (1/2048)	
DATE	EIGHT-PLACE (1/4096)	
DATE	TEN-PLACE (1/10240)	
DATE	TWELVE-PLACE (1/20480)	

WIRING INSTL-BODY, 12V (RF)

SHEET 1 OF 8

134242

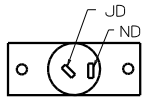

DETAIL BC

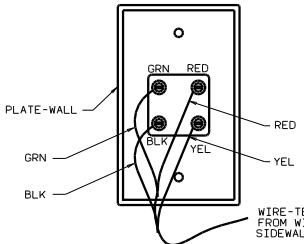

DETAIL BD

- (WIN) LAMP-OVHD DINETTE
- (ITA) 93575-12-CHT BULB
- 93575-13-CHT BULB
- 117806-01-000(2) CONNECTOR
- 58028-01-000(2)

- RADIO-SPEAKER 94097-01-000
- GRILLE 90026-01-CHT
- SCREW G11-08-08B (4)

- LAMP-READING SWIVEL ROUND 132427-01-CHT
- SCREW G11-06-10J (4)
- CONNECTOR 58028-01-000 (4)

- (21V) SPEAKER-CUBE 124883-02-000
- SCREW G11-08-12U (2)

WIRE ASM-OVHD 134456-01-000

9 & 15 PIN HOUSING TO WIRE ASM-ROOF

2 PIN HOUSING AND GROUND WIRE TO INVERTER

RECP-12V 132958-01-000 (SEE DETAIL BC) SCREW G11-06-10U (2) PLATE-WALL TELEPHONE 93253-01-CHT (SEE DETAIL BD) SPACER 133713-06-CHT SCREW G13-06-24U (4)

TO LOAD SHEDDER BOARD (SEE DETAIL BE)

WIRES ROUTE UP THROUGH FLOOR IN THIS AREA

L02-1

L01-1 2

TO SIDE MARKER LAMP

TO EXTERIOR SERVICE LAMP

SWITCH (SEE DETAIL BF)

PHONE WIRE (SEE DETAIL BB)

SWITCH 132180-01-CHT PLATE-SWITCH 98351-01-CHT SCREW G11-06-10J (2)

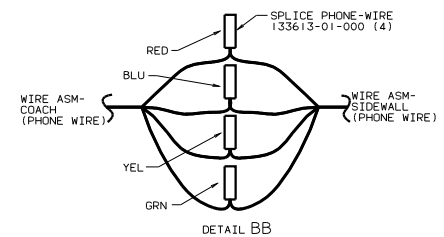

DETAIL BB

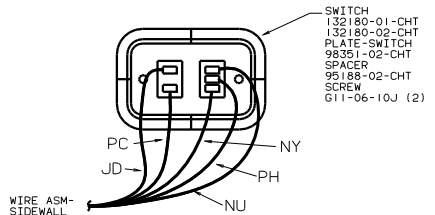

VIEW BF

- (571) RADIO SPEAKERS
- (44X) BED-QUEEN SIDEWALL
- (265) CODES/STANDARDS-CSA/CMVSS
- (21V) SOUND SYSTEM DELUXE
- (20F) DELUXE SOUND SYSTEM-WITHOUT
- (E3) ENERGY MANAGEMENT SYSTEM
- (1B1) CODES/STANDARDS USA
- (09L) SLIDEOUT ROOM FRONT LEFT
- (WIN) WINNEBAGO ONLY
- (ITA) ITASCA ONLY

NOTES: (1) WIRE IN SIDEWALL

FOR ELECTRICAL TORQUE SPECIFICATIONS SEE DWG NO. 128783-01-000

FOR ELECTRICAL CALLOUTS SEE DWG NO. 121339-01-000

00 L36W (1B1) (265) (44X) (09L) WIRING INSTL-RODY.12V (LEFT) SHEET 2 OF 8 134242

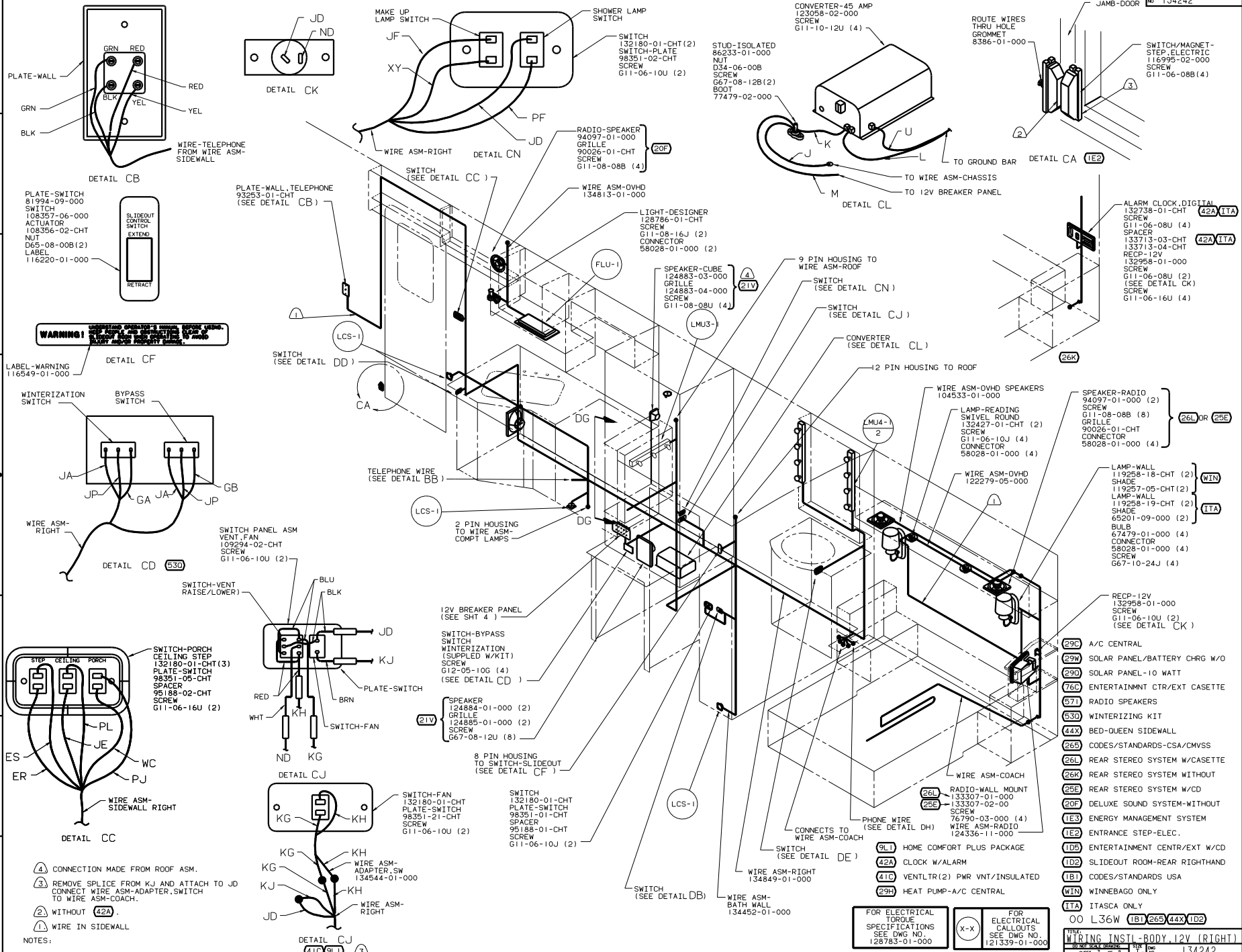

**WARNING!**  
 DO NOT CONNECT TO BATTERY OR POWER SOURCE UNTIL ALL WIRING IS COMPLETE.  
 DO NOT CONNECT TO BATTERY OR POWER SOURCE UNTIL ALL WIRING IS COMPLETE.  
 DO NOT CONNECT TO BATTERY OR POWER SOURCE UNTIL ALL WIRING IS COMPLETE.

- NOTES:
- ④ CONNECTION MADE FROM ROOF ASM.
  - ③ REMOVE SPLICE FROM KJ AND ATTACH TO JD CONNECT WIRE ASM-ADAPTER, SWITCH TO WIRE ASM-COACH.
  - ② WITHOUT (42A).
  - ① WIRE IN SIDEWALL

- ALARM CLOCK-DIGITAL 132738-01-CHT SCREW G11-06-08U (4) SPACER 133713-03-CHT 133713-04-CHT RECIP-12V 132958-01-000 SCREW G11-06-08U (2) (SEE DETAIL CK) SCREW G11-06-16U (4)
- ④2A (ITA)
- ④2A (ITA)
- ②6K
- SPEAKER-RADIO 94097-01-000 (2) SCREW G11-08-08B (8) GRILLE 90026-01-CHT CONNECTOR 58028-01-000 (4)
- ②6L OR ②6E
- LAMP-WALL 119258-18-CHT (2) SHADE 119257-05-CHT (2) LAMP-WALL 119258-19-CHT (2) SHADE 65201-09-000 (2) BULB 67479-01-000 (4) CONNECTOR 58028-01-000 (4) SCREW G67-10-24J (4)
- ① WIN
- ① TA
- RECIP-12V 132958-01-000 SCREW G11-06-10U (2) (SEE DETAIL CK)
- ②9C
- A/C CENTRAL
- ②9M
- SOLAR PANEL/BATTERY CHR9 W/O
- ②9O
- SOLAR PANEL-10 WATT
- ENTERTAINMNT CTR/EXT CASETTE
- ⑤7I
- RADIO SPEAKERS
- ⑤3O
- WINTERIZING KIT
- ④4X
- BED-QUEEN SIDEWALL
- ②6S
- CODES/STANDARDS-CSA/CMVSS
- ②6L
- REAR STEREO SYSTEM W/CASSETTE
- ②6K
- REAR STEREO SYSTEM WITHOUT
- ②6E
- REAR STEREO SYSTEM W/CD
- ②0F
- DELUXE SOUND SYSTEM-WITHOUT
- ①E3
- ENERGY MANAGEMENT SYSTEM
- ①E2
- ENTRANCE STEP-ELEC.
- ①D5
- ENTERTAINMENT CENTR/EXT W/CD
- ①D2
- SLIDEOUT ROOM-REAR RIGHTHAND
- ①B1
- CODES/STANDARDS USA
- ①WIN
- WINNEBAGO ONLY
- ①TA
- ITASCAS ONLY
- 00 L36W ①B1 ②6S ④4X ①D2

FOR ELECTRICAL TORQUE SPECIFICATIONS SEE DWG NO. 128783-01-000

X-X FOR ELECTRICAL CALLOUTS SEE DWG NO. 121339-01-000

FOR ELECTRICAL CALLOUTS SEE DWG NO. 128783-01-000

FOR ELECTRICAL CALLOUTS SEE DWG NO. 121339-01-000

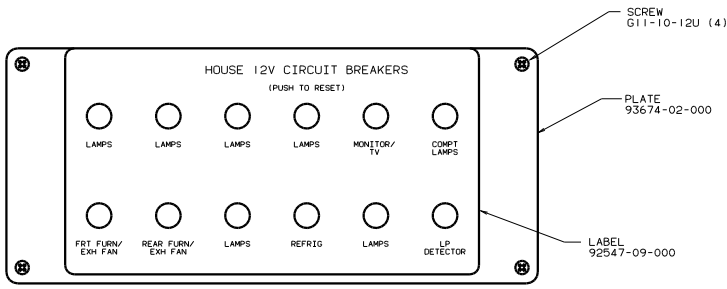

CIRCUIT BREAKER (FRONT VIEW)

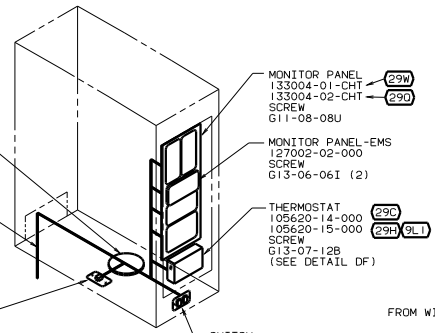

VIEW DG-DG

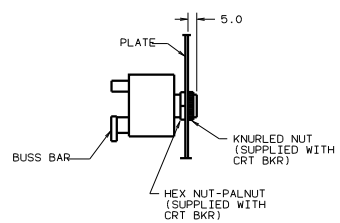

SECTION DA-DA

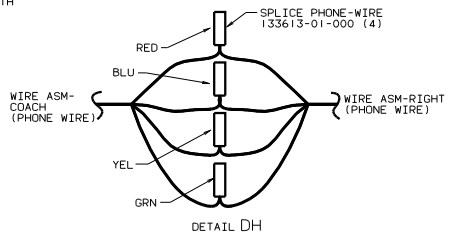

DETAIL DH

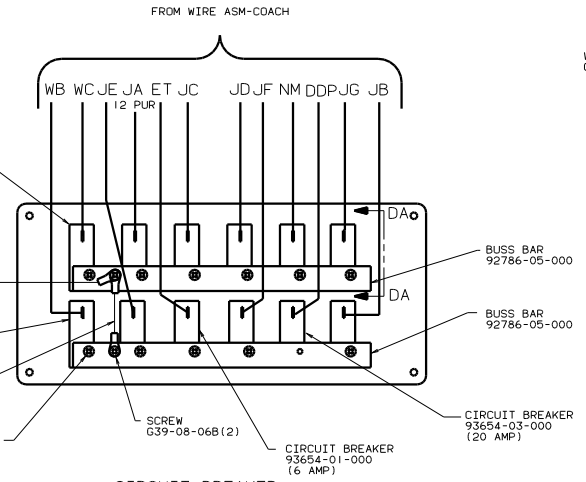

CIRCUIT BREAKER (BACK VIEW)

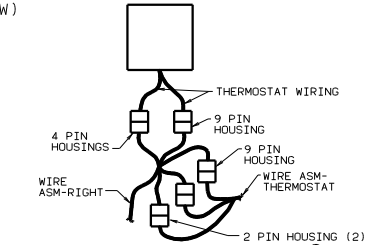

DETAIL BF

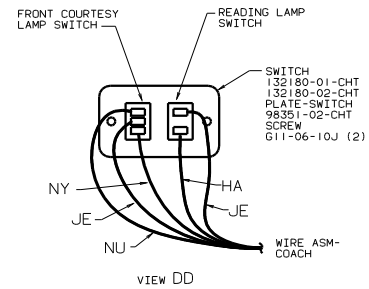

VIEW DD

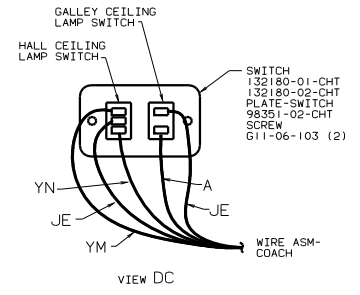

VIEW DC

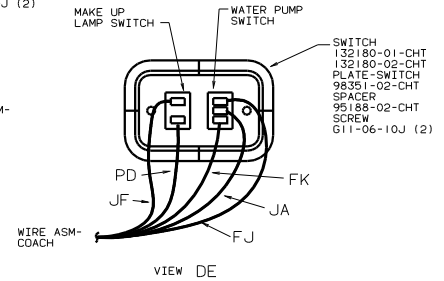

VIEW DE

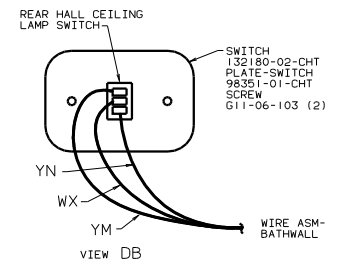

VIEW DB

NOTES: 1. WITHOUT 29H PLUG THE TWO, TWO PIN HOUSINGS TOGETHER ON WIRE ASM-RIGHT

FOR ELECTRICAL TORQUE SPECIFICATIONS SEE DWG NO. 128783-01-000

- 9L1 HOME COMFORT PLUS PACKAGE
- 29W SOLAR PANEL/BATTERY CHRG W/O
- 29D SOLAR PANEL-10 WATT
- 29H HEAT PUMP-A/C CENTRAL
- 29C A/C CENTRAL
- 26S CODES/STANDARDS-CEN/CMVSS
- 1B1 CODES/STANDARDS USA

TITLE: WIRING INSTL-BODY(12 BP)	
30 NO SCALE CHG	REV 1 E
SHEET 4 OF 8	134242

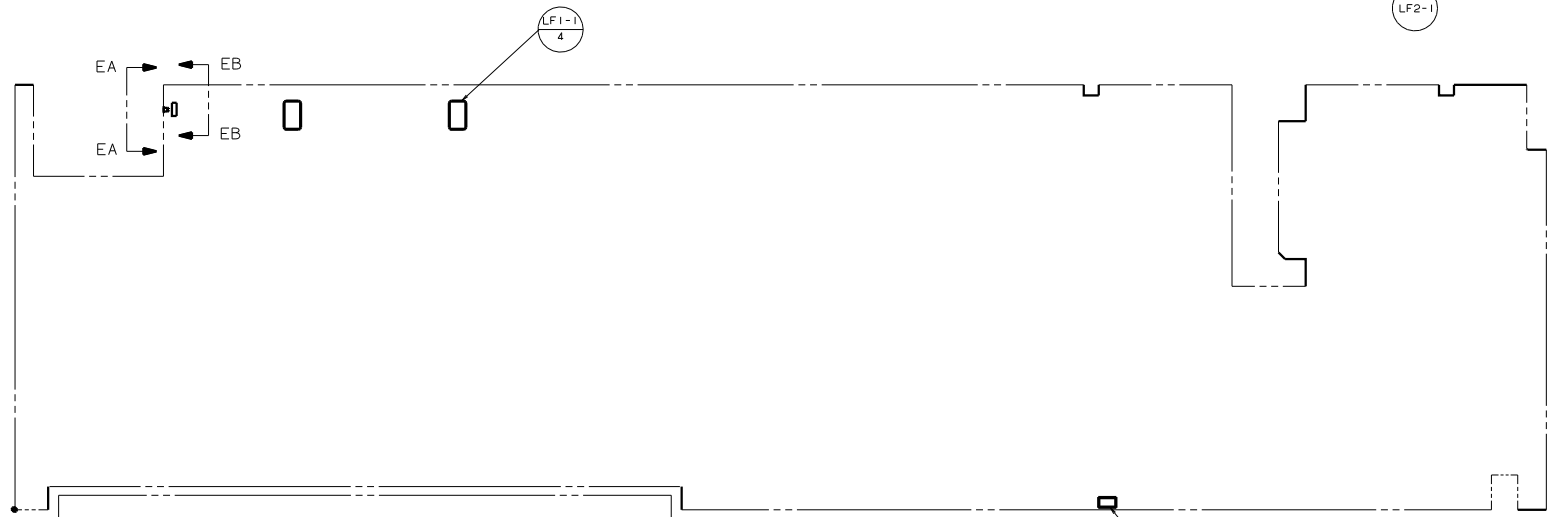
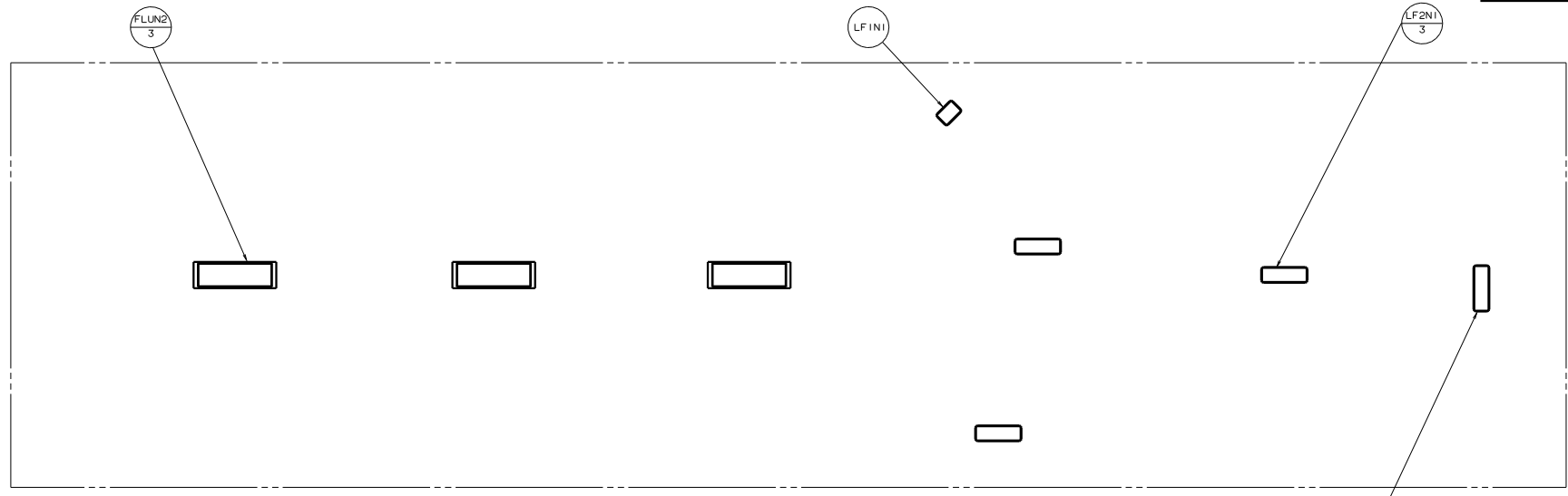

WIRE ASM-  
COMPT LAMPS  
125266-10-000

SWITCH-BATTERY-DISC  
108357-06-000  
ACTUATOR-SWITCH  
108356-11-CHT  
PLATE-SWITCH  
98351-07-CHT  
SCREW  
G11-06-16U (2)

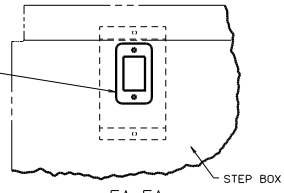

UPPER FLOOR  
SUPPORT FRAME

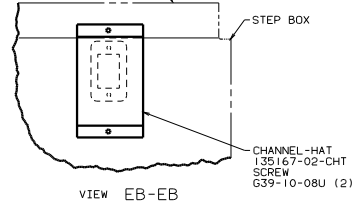

LAMP  
86280-01-000  
SCREW  
G67-10-12U (4)  
CONNECTOR  
58028-01-000 (2)

- (48W) LIGHTS-INCANDESCENT
- (48V) LIGHTS-FLUORESCENT
- (265) CODES/STANDARDS-CSA/CMVSS
- (1B1) CODES/STANDARDS USA

00 L36W (1B1) (265)

FOR ELECTRICAL  
TORQUE  
SPECIFICATIONS  
SEE DWG NO.  
128783-01-000

FOR ELECTRICAL  
CALLOUTS  
SEE DWG NO.  
121339-01-000

WIRING INSTL-BODY, 12V (CL)	
NO. OF SHEETS	TOT. SHEET NO.
5 OF 8	134242

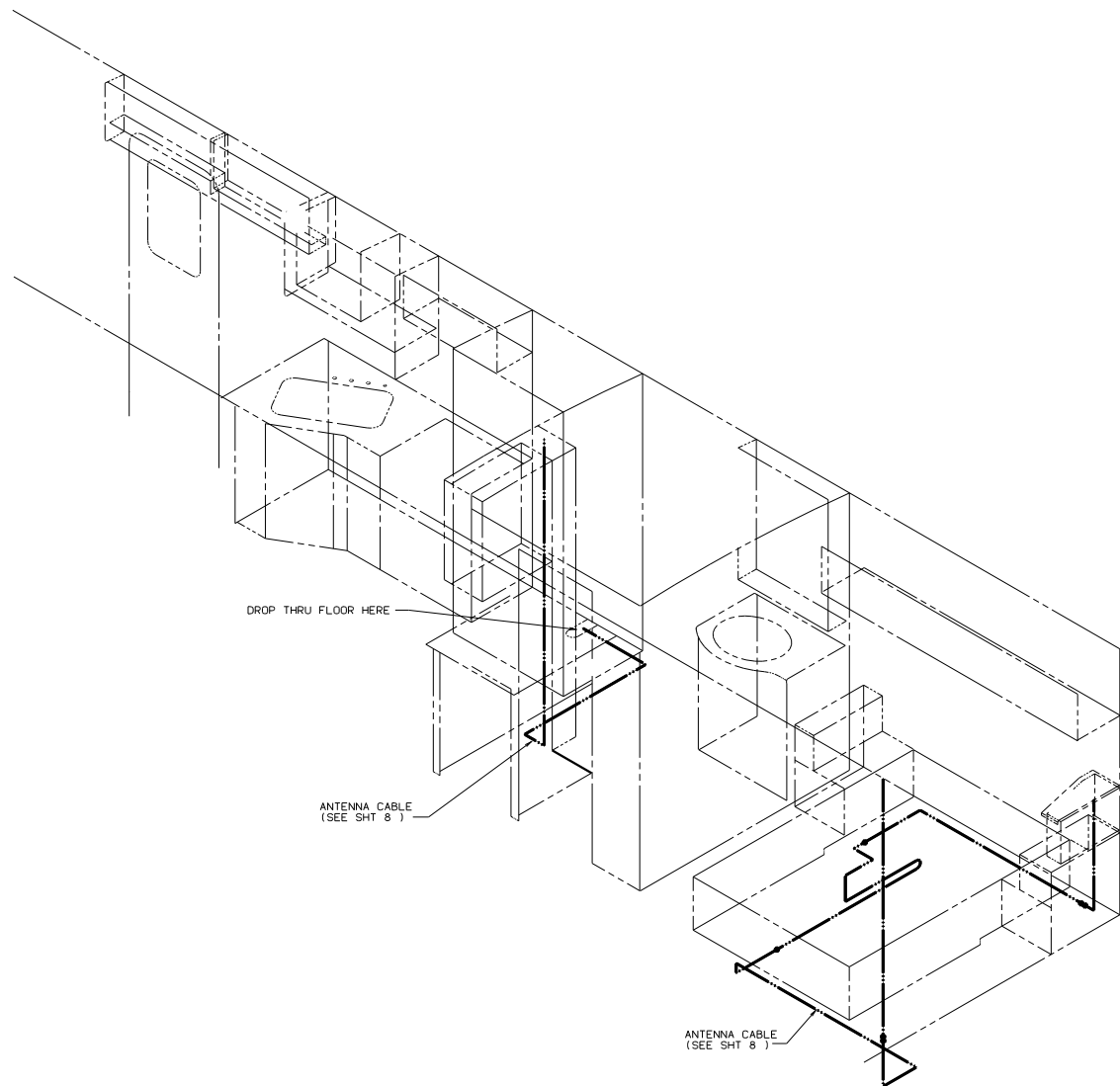
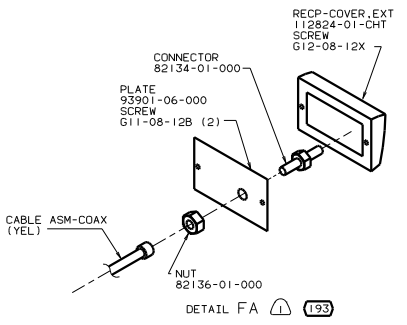

- ENTERTAINMNT CTR/EXT CASSETTE
  - REAR STEREO SYSTEM W/CASSETTE
  - REAR STEREO SYSTEM W/CD
  - ENTERTAINMENT CENTR/EXT W/CD
  - TV ANTENNA
  - CODES/STANDARDS-CSA/CMVSS
  - CODES/STANDARDS USA
- 00 L36W

NOTES:  
 USE WITHOUT OR

GROMMET  
23942-01-000

WIRE ASM-THERMOSTAT  
(COIL UP AND TIE EXCESS  
WIRE IN BASEMENT AREA  
WITH WIRE TIE 8343-02-000)

TO THERMOSTAT

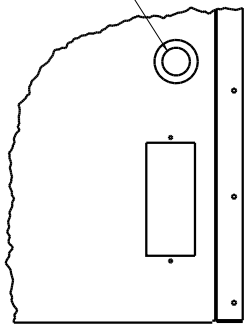

VIEW GB-GB

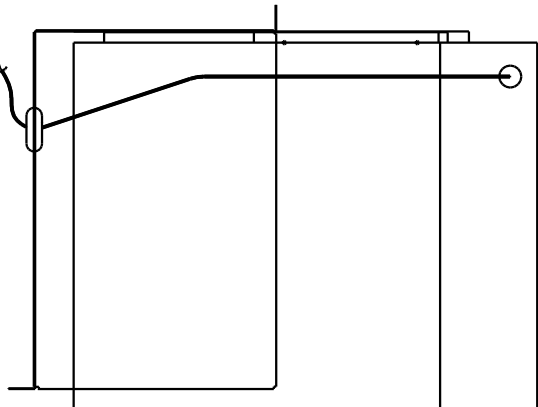

VIEW GA-GA

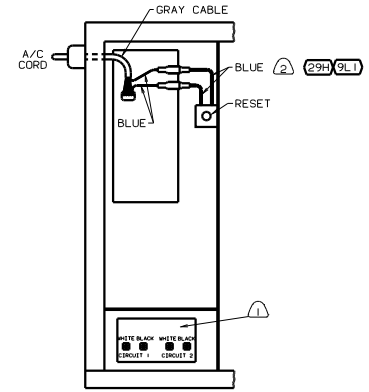

VIEW GC-GC

- CONNECT BLUE WIRES FROM RESET TO THE BLUE WIRES WITH SPADE TERMINALS ON A/C CORD WITH (29H) & (9L1) FEATURE.
- SEE WIRING INSTL-BODY.110V FOR ADDITIONAL INFORMATION.

- (9L1) HOME COMFORT PLUS PACKAGE
- (29H) HEAT PUMP-A/C CENTRAL
- (265) CODES/STANDARDS-CSA/CMVSS
- (1B1) CODES/STANDARDS USA

00 L36W (1B1) (265)



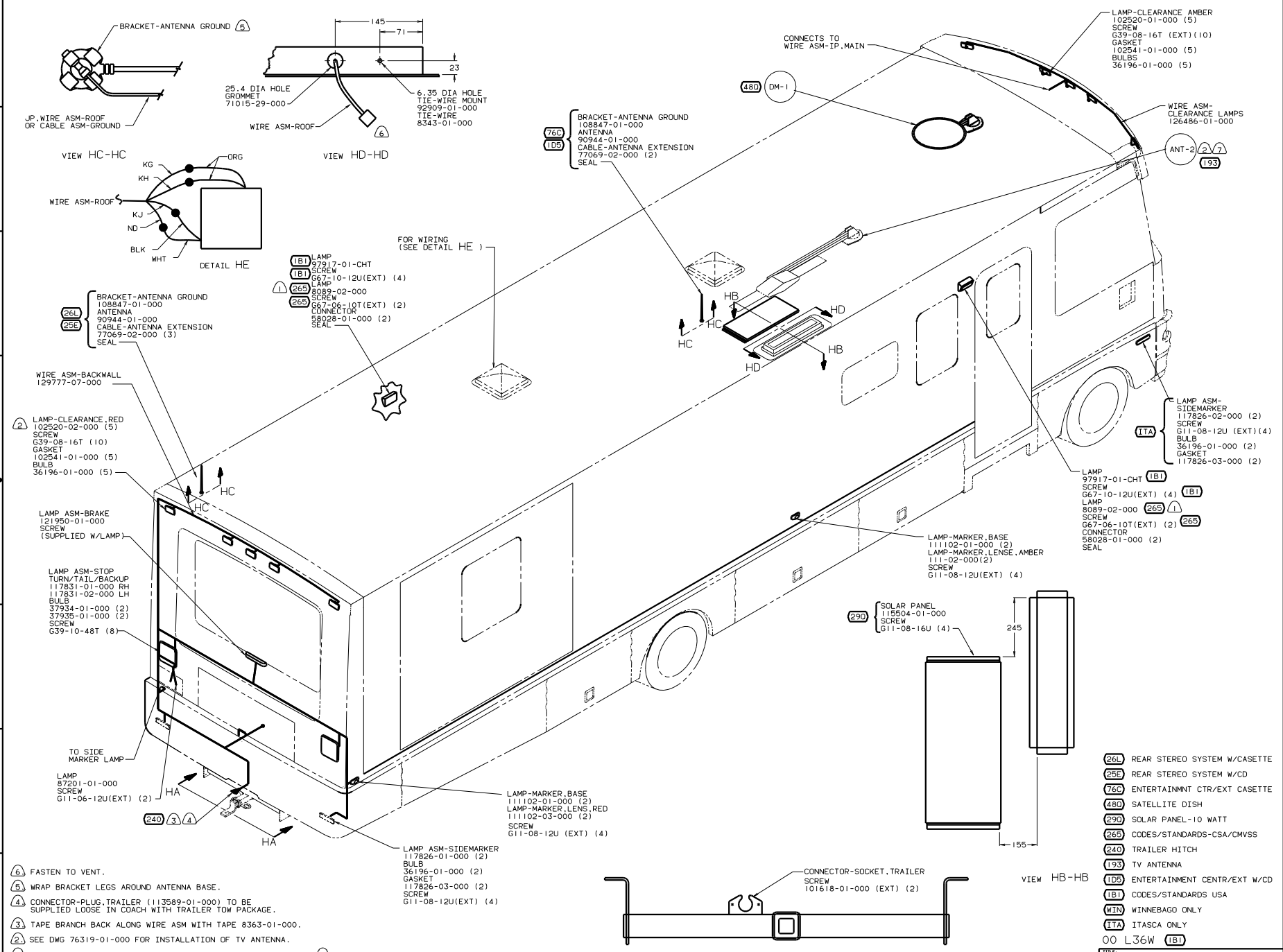

- (A) FASTEN TO VENT.
- (B) WRAP BRACKET LEGS AROUND ANTENNA BASE.
- (C) CONNECTOR-PLUG, TRAILER (113589-01-000) TO BE SUPPLIED LOOSE IN COACH WITH TRAILER TOW PACKAGE.
- (D) TAPE BRANCH BACK ALONG WIRE ASM WITH TAPE 8363-01-000.
- (E) SEE DWG 76319-01-000 FOR INSTALLATION OF TV ANTENNA.
- (F) INSTALL WITH WIRES TOWARDS ROOF.
- (G) ADD RUBBER BUMPERS TO ROOF UNDER EACH END OF ANTENNA TO PREVENT CONTACT WITH ROOF.

- (26L) REAR STEREO SYSTEM W/CASSETTE
- (26E) REAR STEREO SYSTEM W/CD
- (76C) ENTERTAINMT CTR/EXT CASSETTE
- (48D) SATELLITE DISH
- (29D) SOLAR PANEL-10 WATT
- (265) CODES/STANDARDS-CSA/CMVSS
- (24D) TRAILER HITCH
- (193) TV ANTENNA
- (1D5) ENTERTAINMENT CENTR/EXT W/CD
- (1B1) CODES/STANDARDS USA
- (WIN) WINNEBAGO ONLY
- (ITA) ITASCA ONLY
- 00 L36W (1B1)