



DANGER

Danger of electrical shock, burns or death. Always remove all power sources before attempting any repair, service or diagnostic work. Power can be present from shore power, generator, inverter or battery. All power sources must be disabled and secured before performing any service.



CAUTION

If you lack the skills, tools or equipment to perform diagnostic or repair work leave such work to an authorized Winnebago Industries dealer or other qualified shop.

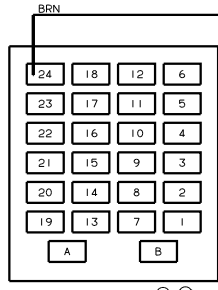

TO GM TAIL LAMP ASSEMBLY (UNDER DRIVER SEAT PED.)

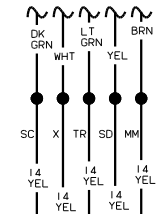

CHASSIS GROUND RAIL

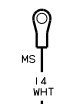

WIRE ASM-BACKWALL (LOCATED ON LEFT CHASSIS RAIL # BKWL)

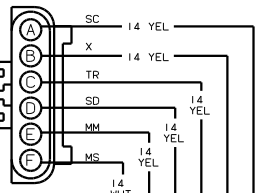

TRAILER HITCH ASM

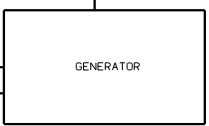
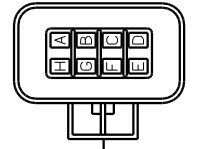
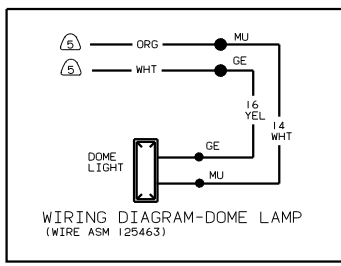
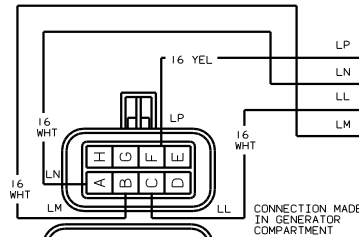
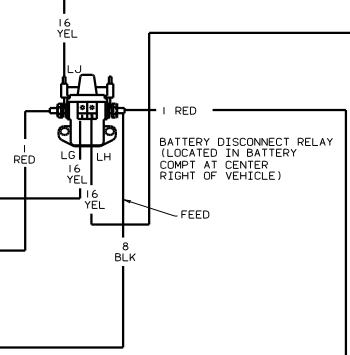
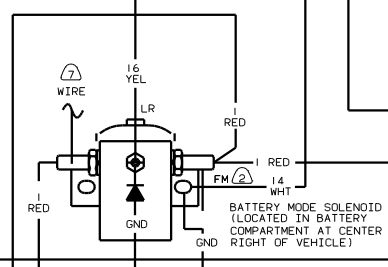
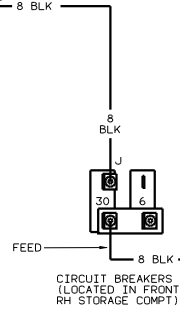
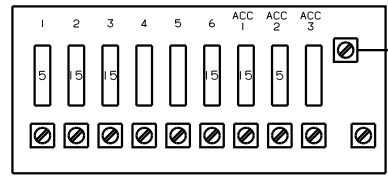
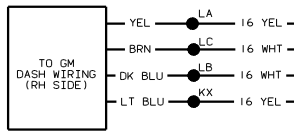
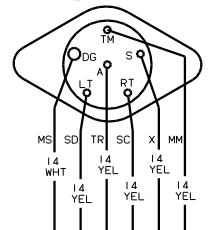

- NOTES:
- ⑦ SEE SHT 5 FOR ADDITIONAL INFORMATION.
 - ⑧ SEE WIRING DIAGRAM AUTO LAMPS FOR ADDITIONAL INFORMATION.
 - ⑨ SEE MANUFACTURER'S DIAGRAM FOR ADDITIONAL INFORMATION.
 - ④ SEE SHT 3 FOR ADDITIONAL INFORMATION.
 - ③ CHASSIS SUPPLIED.
 - ② WIRE FM ATTACHES TO SOLENOID MOUNTING BOLT.
 - 1. SEE WIRING INSTL-CHASSIS FOR ADDITIONAL INFORMATION.

GROUND STUD (LOCATED NEAR CHASSIS BATTERY)

GROUND

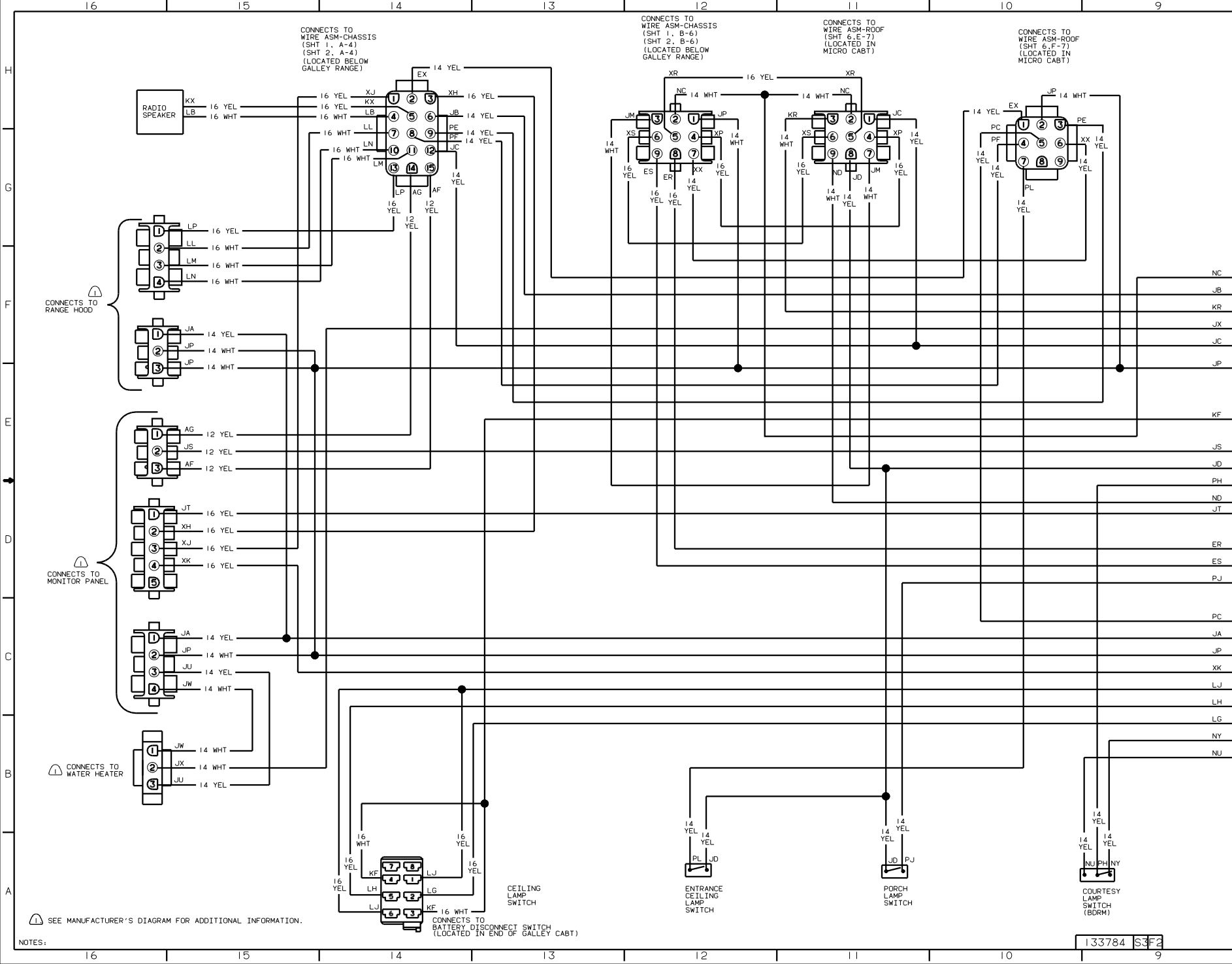

CONNECTS TO WIRE ASM-CHASSIS (SHT 1, H-6) (SHT 2, H-6) (LOCATED BELOW BATH VANITY)

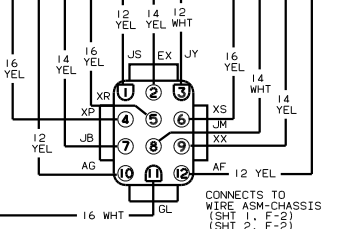
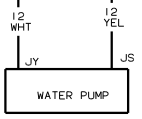
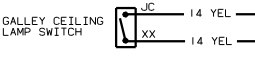
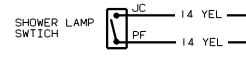
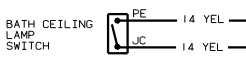
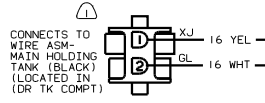
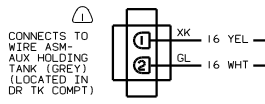
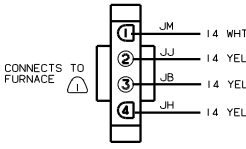
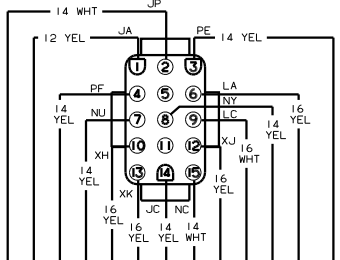
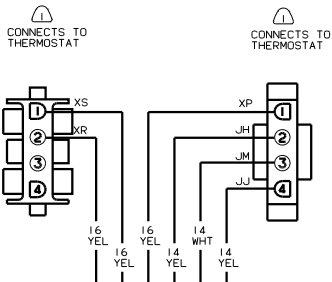

CONNECTS TO WIRE ASM-CHASSIS (SHT 1, F-2) (SHT 2, F-2) (LOCATED BELOW BATH VANITY)

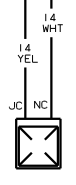
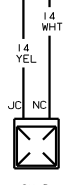
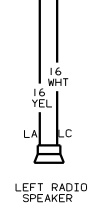
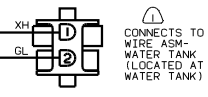
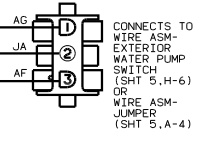

WIRING DIAGRAM-LEFT (WIRE ASM 133788)

00 327P

NOTES: 1 SEE MANUFACTURER'S DIAGRAM FOR ADDITIONAL INFORMATION.

| | |
|---------------------------------|------------------|
| TITLE: WIRING DIAGRAM-BODY, 12V | |
| NO. OF SHEETS: 7 | SHEET NO. 4 OF 7 |
| DATE: 1/6 | 133784 |

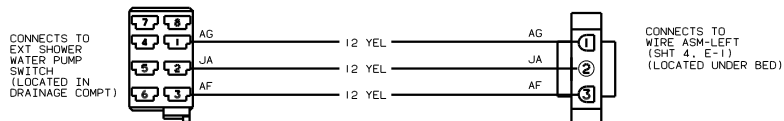

CONNECTS TO WIRE ASM-LEFT (SHT 4, E-1) (LOCATED UNDER BED)

CONNECTS TO EXT SHOWER WATER PUMP SWITCH (LOCATED IN DRAINAGE COMPT)

WIRING DIAGRAM-PUMP, EXT SHOWER
(WIRE ASM 103494-05)
(WITH EXTERIOR SHOWER)

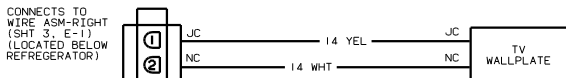

CONNECTS TO WIRE ASM-RIGHT (SHT 3, E-1) (LOCATED BELOW REFRIGERATOR)

WIRING DIAGRAM TV
(BDRM TV SHELF)
(WIRE ASM 093051-04) (TWIN)
(WIRE ASM 77093-09) (DOUBLE)

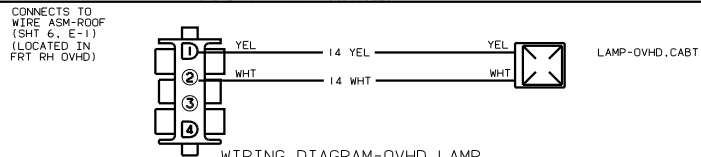

CONNECTS TO WIRE ASM-ROOF (SHT 6, E-1) (LOCATED IN FRT RH OVHD)

WIRING DIAGRAM-OVHD LAMP
(WIRE ASM 133870)
(W/FRT ENTERTAINMENT CENTER)

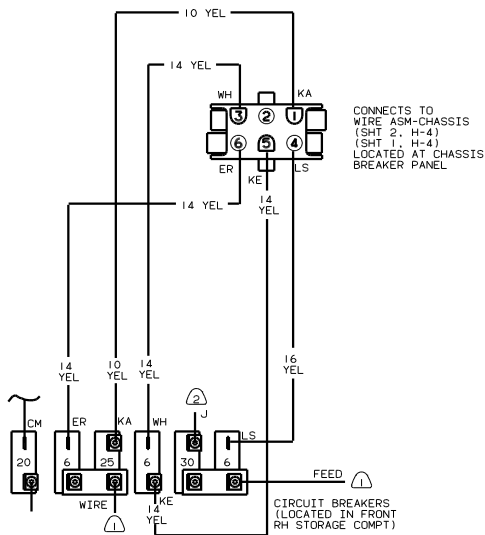

CONNECTS TO WIRE ASM-CHASSIS (SHT 2, H-4) (SHT 1, H-4) LOCATED AT CHASSIS BREAKER PANEL

WIRING DIAGRAM-PANEL BREAKERS
(131799-02)

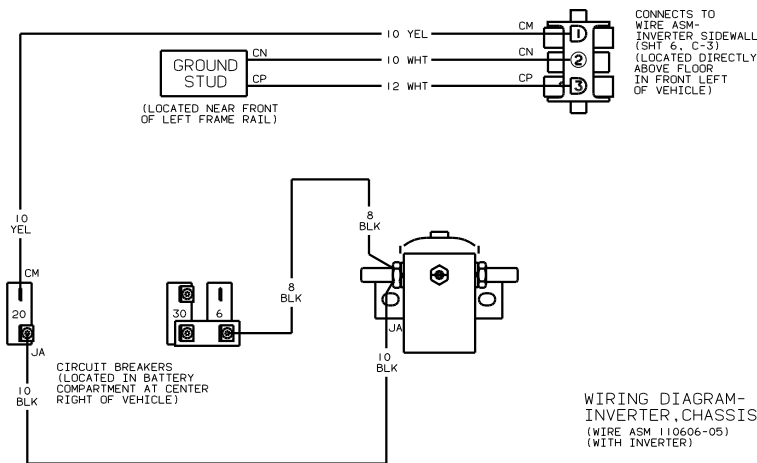

CONNECTS TO WIRE ASM-INVERTER, SIDEWALL (SHT 6, C-3) (LOCATED DIRECTLY ABOVE FLOOR IN FRONT LEFT OF VEHICLE)

WIRING DIAGRAM-INVERTER, CHASSIS
(WIRE ASM 110606-05)
(WITH INVERTER)

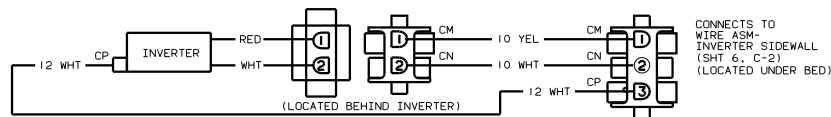

CONNECTS TO WIRE ASM-INVERTER, SIDEWALL (SHT 6, C-2) (LOCATED UNDER BED)

WIRING DIAGRAM-INVERTER
(WIRE ASM 1009311)
(WITH INVERTER)

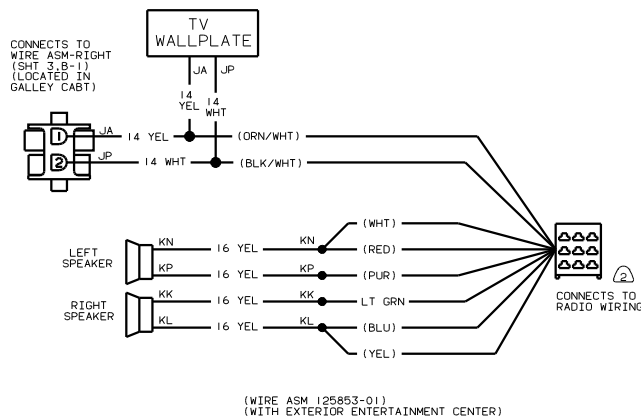

CONNECTS TO WIRE ASM-RIGHT (SHT 3, B-1) (LOCATED IN GALLEY CABT)

WIRING DIAGRAM TV WALLPLATE

CONNECTS TO RADIO WIRING

(WIRE ASM 125853-01)
(WITH EXTERIOR ENTERTAINMENT CENTER)

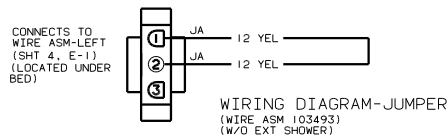

CONNECTS TO WIRE ASM-LEFT (SHT 4, E-1) (LOCATED UNDER BED)

WIRING DIAGRAM-JUMPER
(WIRE ASM 103493)
(W/O EXT SHOWER)

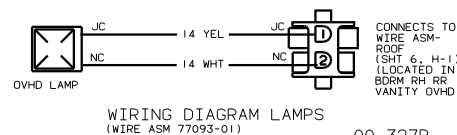

CONNECTS TO WIRE ASM-ROOF (SHT 6, H-1) (LOCATED IN BDRM RH RR VANITY OVHD)

WIRING DIAGRAM LAMPS
(WIRE ASM 77093-01)

NOTES: (2) SEE MANUFACTURER'S DIAGRAM FOR ADDITIONAL INFORMATION.

(1) SEE SHT 1 FOR ADDITIONAL INFORMATION.

00 327P

TITLE: WIRING DIAGRAM-BODY, 12V
NO. OF SHEETS: 16
SHEET NO: 5 OF 7
REV: 1
133784

