



DANGER

Danger of electrical shock, burns or death. Always remove all power sources before attempting any repair, service or diagnostic work. Power can be present from shore power, generator, inverter or battery. All power sources must be disabled and secured before performing any service.



CAUTION

If you lack the skills, tools or equipment to perform diagnostic or repair work leave such work to an authorized Winnebago Industries dealer or other qualified shop.

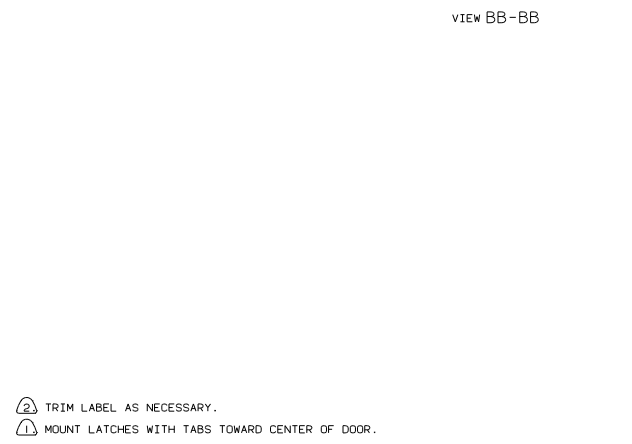
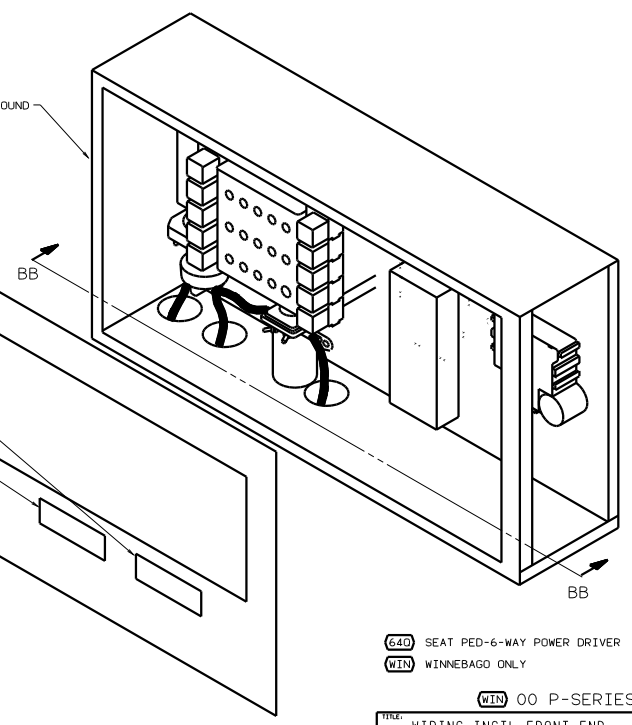
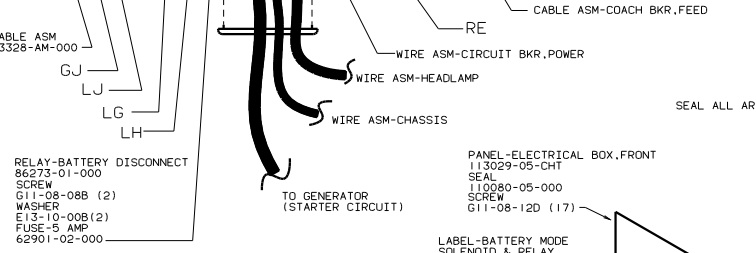
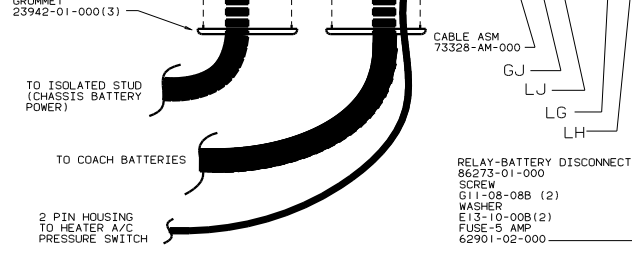
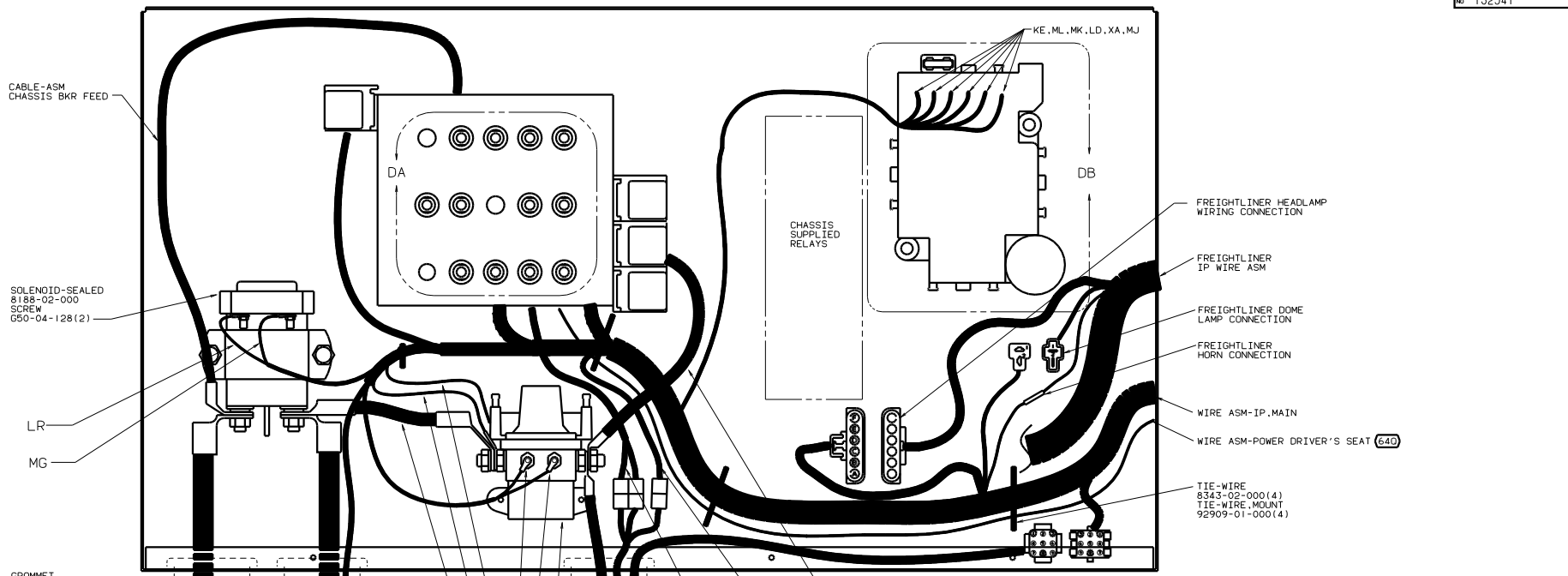

NOTES:
 (2) TRIM LABEL AS NECESSARY.
 (1) MOUNT LATCHES WITH TABS TOWARD CENTER OF DOOR.

(640) SEAT PED-6-WAY POWER DRIVER
 (WIN) WINNEBAGO ONLY
 (WIN) 00 P-SERIES
 TITLE: WIRING INSTL-FRONT END
 SHEET 2 OF 15
 132541

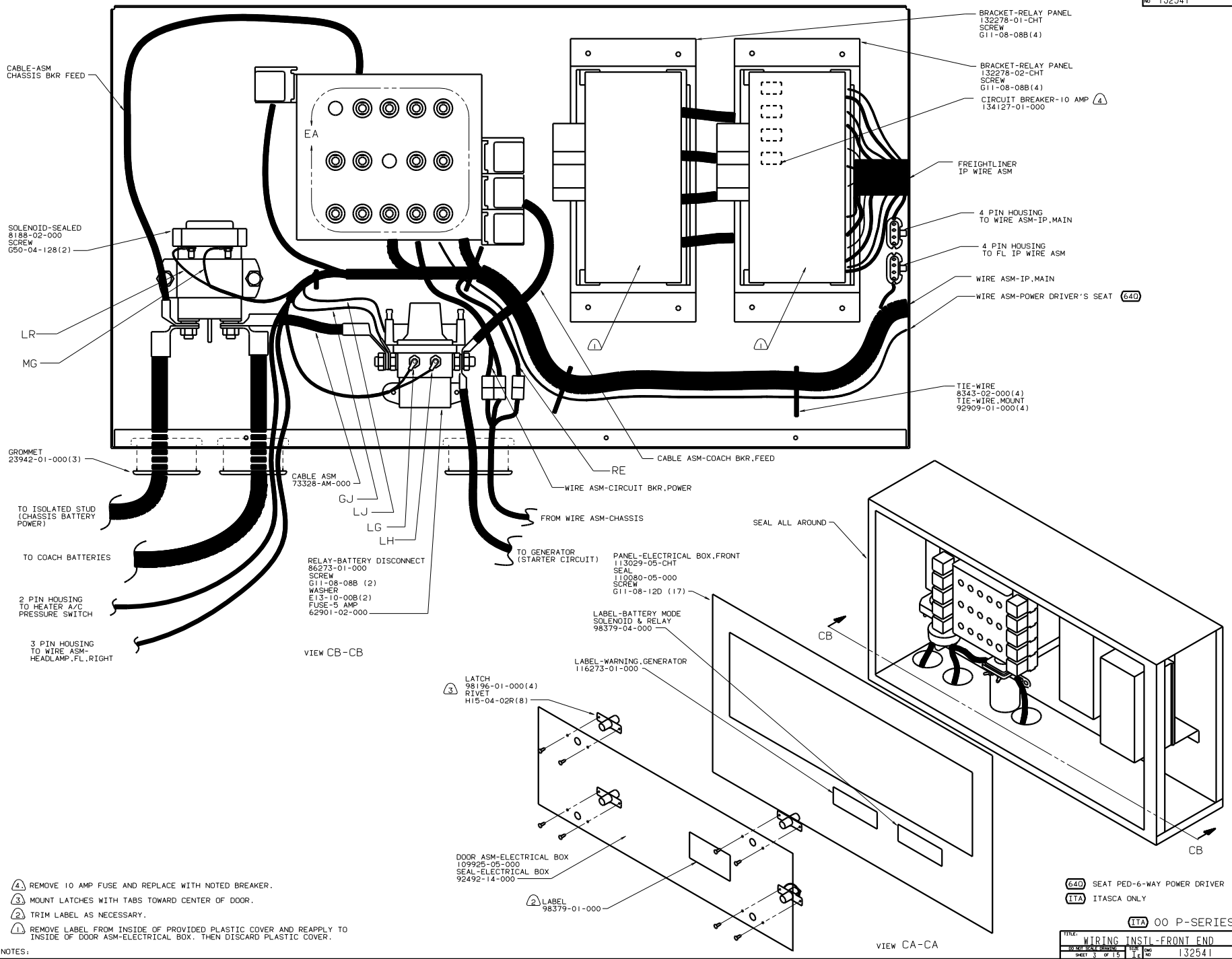

- NOTES:
- ④ REMOVE 10 AMP FUSE AND REPLACE WITH NOTED BREAKER.
 - ③ MOUNT LATCHES WITH TABS TOWARD CENTER OF DOOR.
 - ② TRIM LABEL AS NECESSARY.
 - ① REMOVE LABEL FROM INSIDE OF PROVIDED PLASTIC COVER AND REAPPLY TO INSIDE OF DOOR ASM-ELECTRICAL BOX. THEN DISCARD PLASTIC COVER.

⑥40 SEAT PED-6-WAY POWER DRIVER
 IITA ITASCA ONLY
 IITA 00 P-SERIES
 TITLE: WIRING INSTL-FRONT END
 SHEET 3 OF 15
 132541

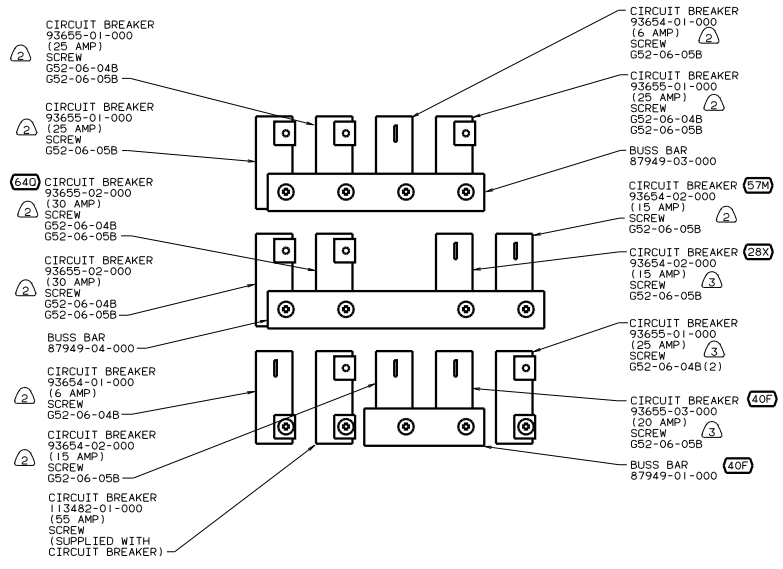

CONTROL PANEL (BACK VIEW)

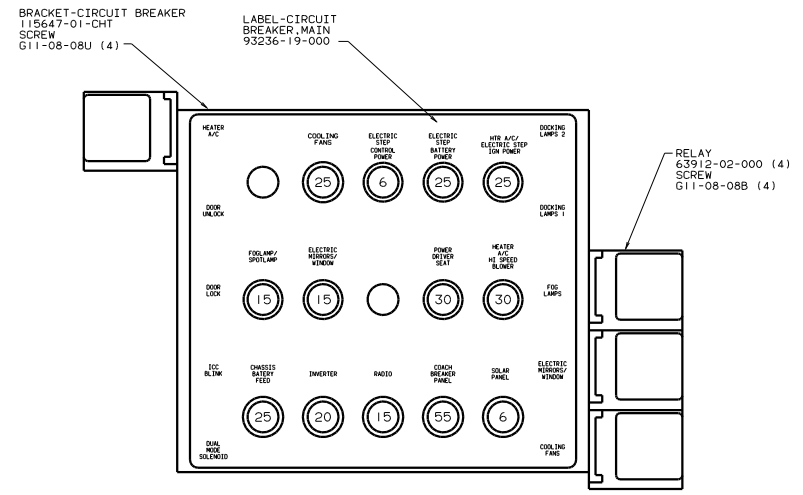

DETAIL EA

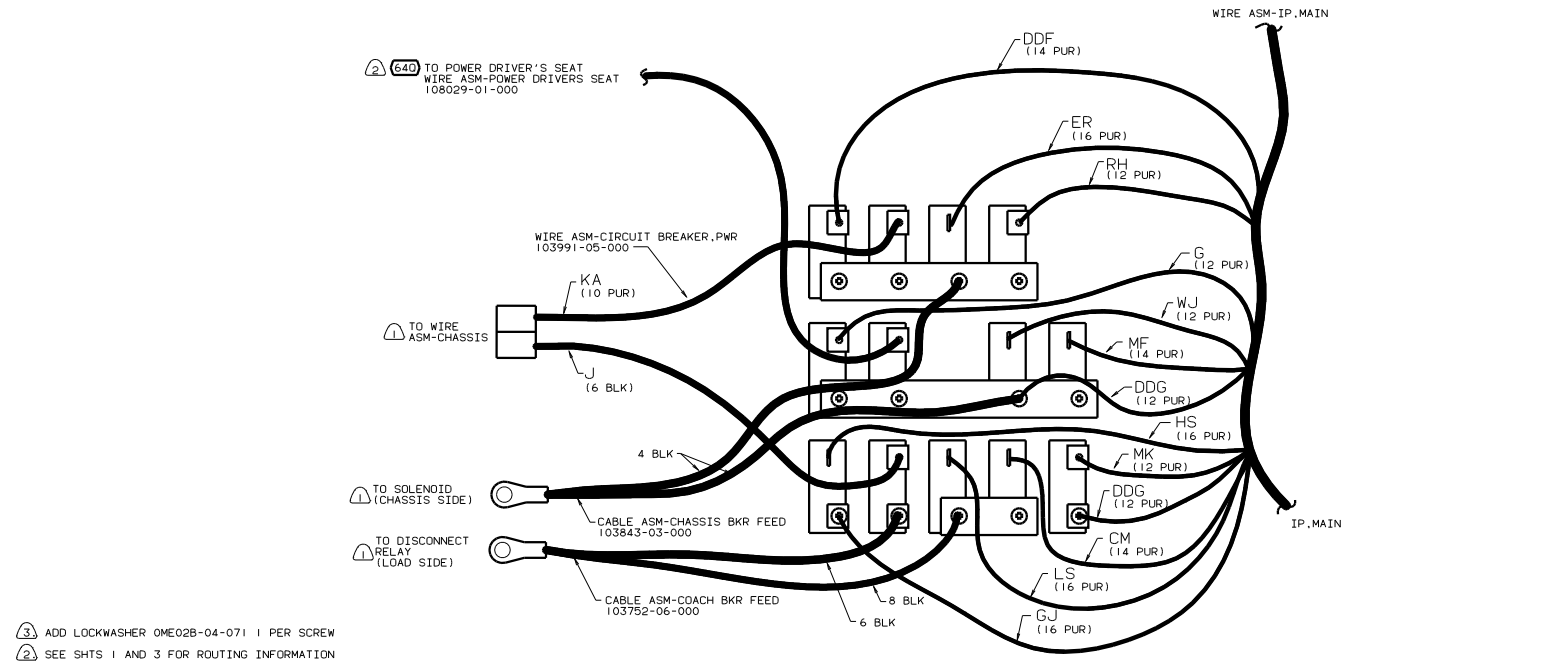

CONTROL PANEL WIRING (BACK VIEW)

- 640 SEAT PED-6-WAY POWER DRIVER
- 57M LAMPS-FOG
- 40P INVERTER-DC/AC-130W
- 28X MIRRORS-EXTERIOR W/DEFROST
- 1TA ITASCA ONLY

NOTES:

- 3 ADD LOCKWASHER OME02B-04-071 1 PER SCREW
- 2 SEE SHTS 1 AND 3 FOR ROUTING INFORMATION
- 1 SEE SHT 3 FOR ROUTING INFORMATION

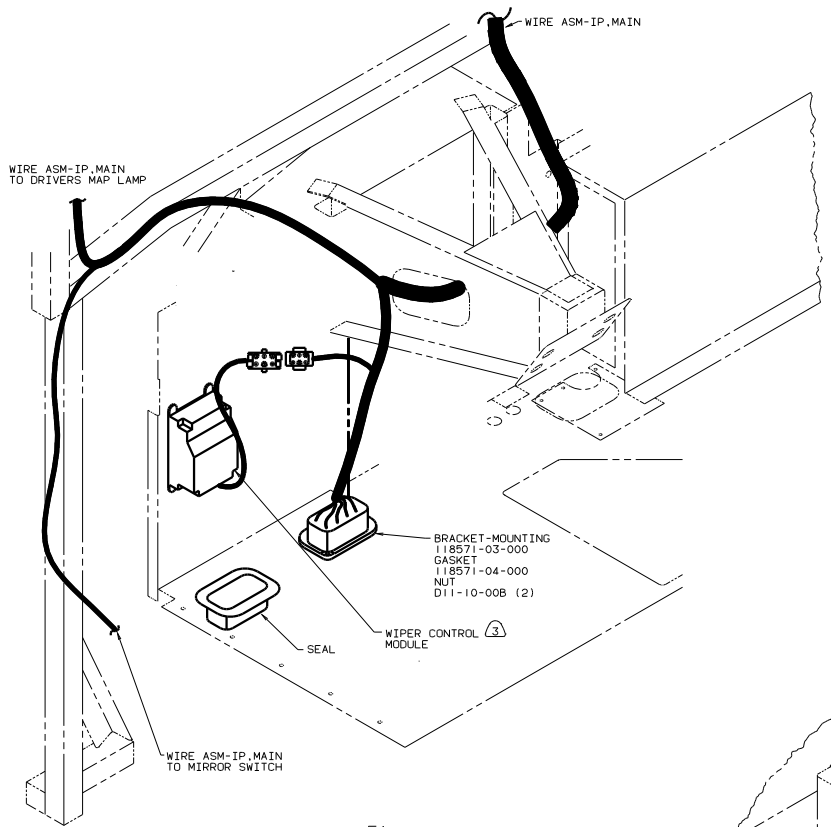

VIEW FA
(WINNEBAGO WIRING SHOWN)

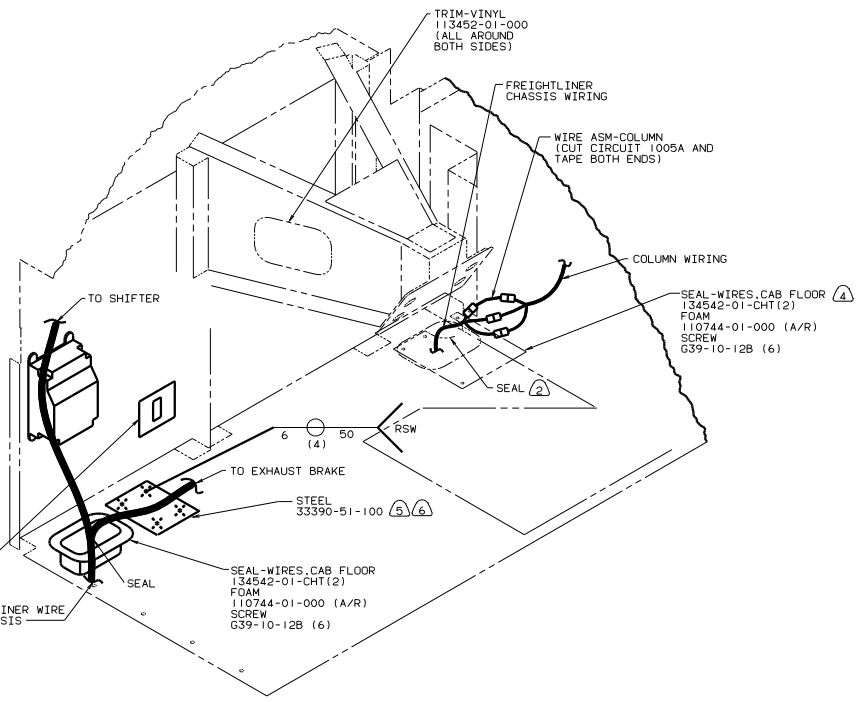

VIEW FA
(FREIGHTLINER WIRING SHOWN)

- (6) USE PRIOR TO 2001 MODELS.
- (5) WELDED ON IN CAB ASSEMBLY.
- (4) PUT 1 SEAL IN FRONT OF HOLE AT CAB PREP.
- (3) SEE WIPER CONTROL INFORMATION FOR INSTALLATION INSTRUCTION
- (2) ROUTE PARK BRAKE VALVE AND AIR LINES FOR DASH GAUGES THRU HERE. COVER WITH CONVOLUTE TUBING 41953 WHERE VISIBLE.

1. BUNDLE AND SECURE ALL EXCESS WIRE.

NOTES:

- (27E) CODES/STANDARDS-CMVSS
- (26E) CODES/STANDARDS-CSA/CMVSS
- (WIN) WINNEBAGO ONLY

(WIN) 00 P-SERIES

TITLE		DRAWING NO.	
WIRING INSTL-FRONT END		132541	
30 THE SCALE SHOWN	1:1	SHEET 6 OF 15	

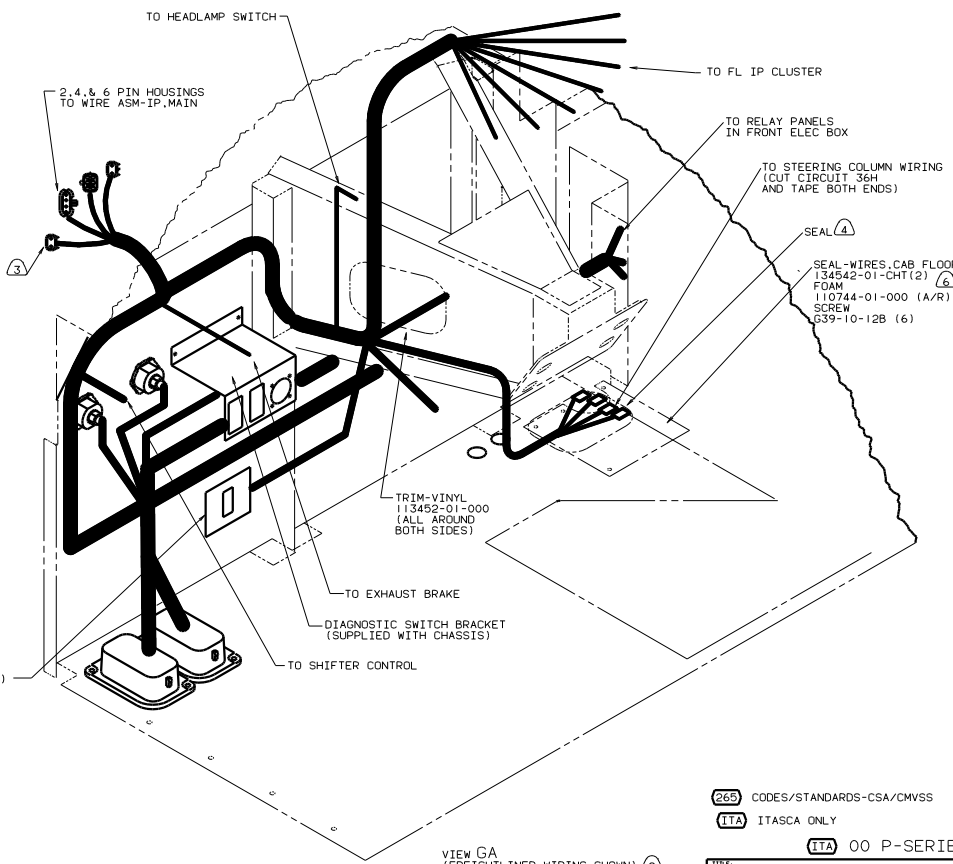
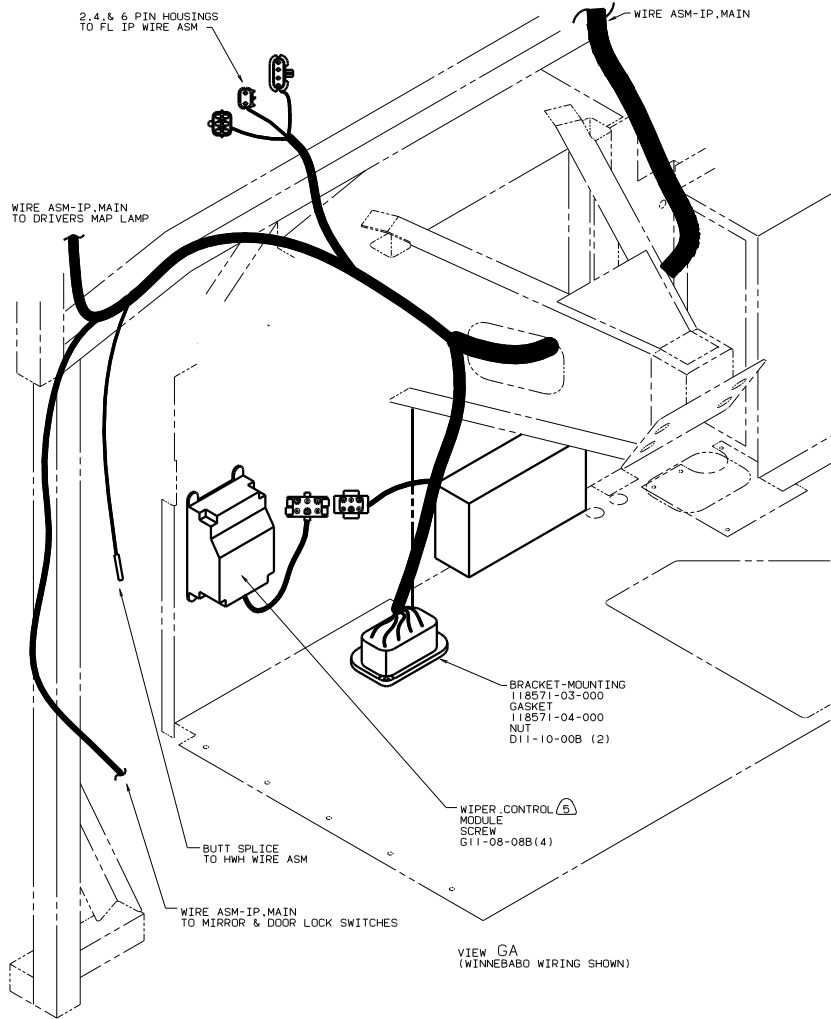

- ⑥ PUT 1 SEAL IN FRONT OF HOLE AT CAB PREP.
- ⑤ SEE WIPER CONTROL INFORMATION FOR INSTALLATION INSTRUCTION
- ④ ROUTE PARK BRAKE VALVE AND AIR LINES FOR DASH GAUGES THRU HERE. COVER WITH CONVOLUTE TUBING 41953 WHERE VISIBLE.
- ③ DO NOT USE SEAT BELT 2 PIN HOUSING
- ② FL IP WIRE ASM SHOULD BE TIED PRIOR TO INSTALLATION. SEE DETAIL HA FOR TYING INSTRUCTIONS.

1. BUNDLE AND SECURE ALL EXCESS WIRE.

②65 CODES/STANDARDS-CSA/CMVSS
①TA ITASCA ONLY

①TA 00 P-SERIES

TITLE: WIRING INSTL-FRONT END	
DO NOT SCALE DIMENSIONS	DATE: 1/8/80
SHEET 7 OF 15	132541

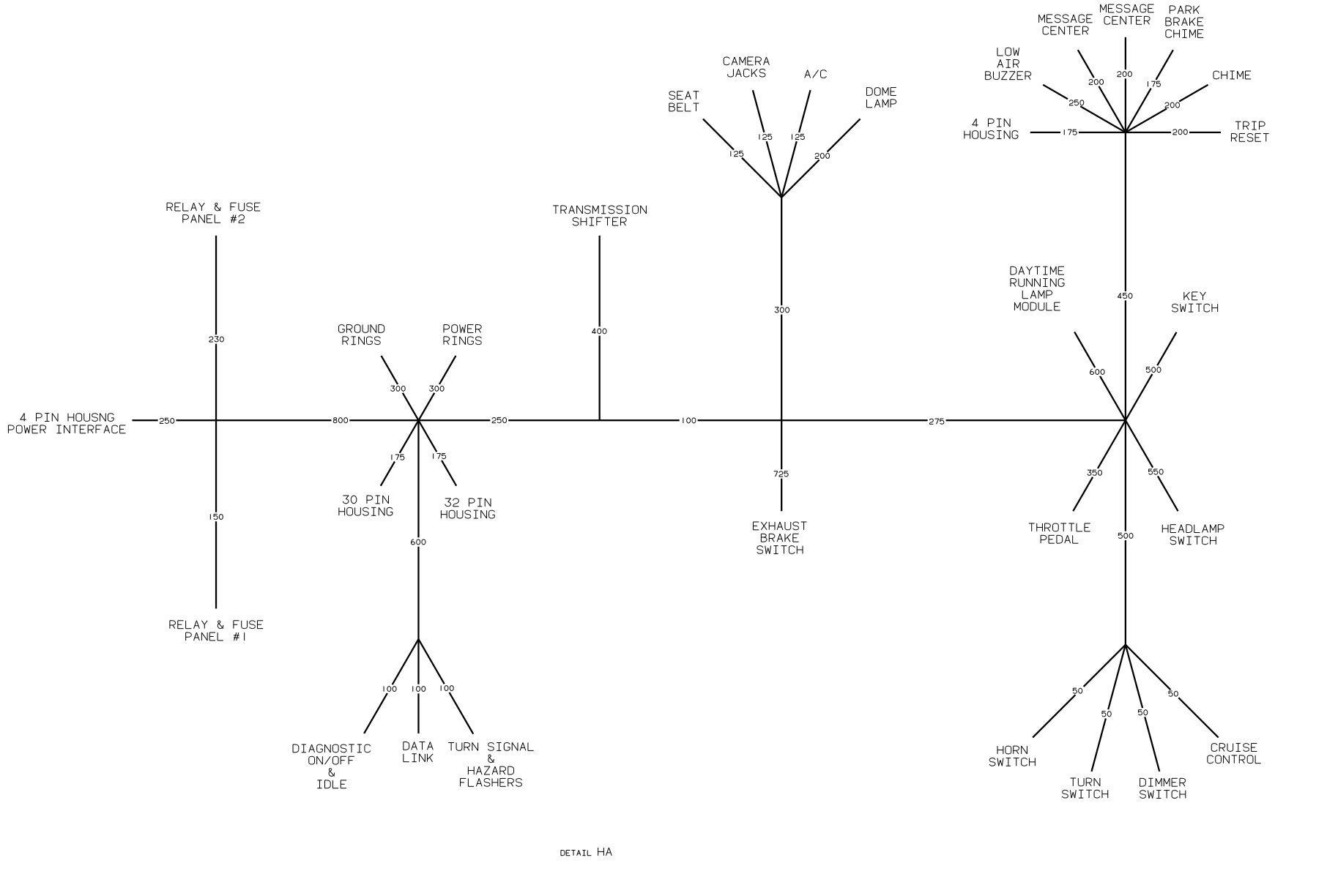

DETAIL HA

1. USE WIRE TIES TO FORM FREIGHTLINER IP WIRE INTO THIS CONFIGURATION.

NOTES:

ITA ITASCA ONLY

ITA OO P-SERIES

TITLE: WIRING INSTL-FRONT END	
NO. OF SHEETS: 8	SHEET NO. 8 OF 15
FIG. NO. 1	132541

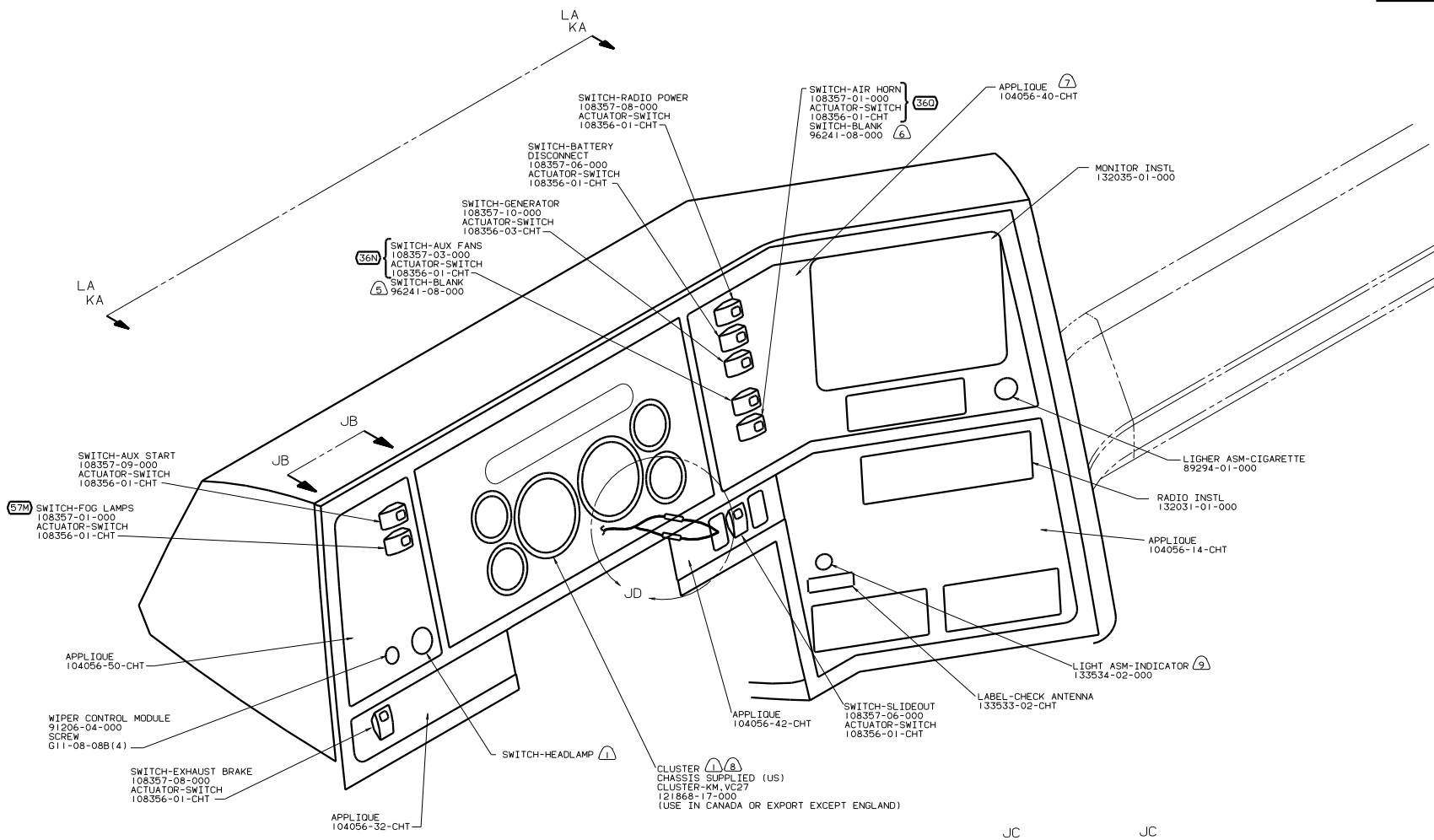

VIEW JA-JA

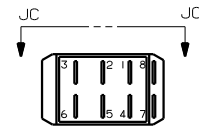

VIEW JB-JB (SWITCH MOUNTING ORIENTATION)

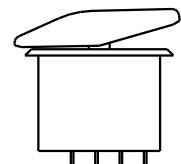

VIEW JC-JC (SWITCH ACTUATOR ORIENTATION)

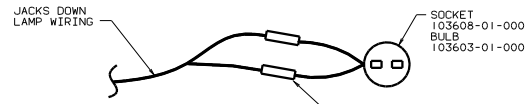

DETAIL JD

- ⑨ DRILL 19.0 DIAMETER HOLE AT LOWER DIMPLE LOCATION.
- ⑧ SEE DETAIL MA FOR INSTRUMENT CLUSTER ASSEMBLY INSTRUCTIONS. (ITA) ONLY.
- ⑦ COVER CLEAR LEGEND ON BEZEL WITH FILM 77031-04-000 (BLANK) OR 77031-03-000 (W/OPTION).
- ⑥ WITHOUT (36D).
- ⑤ WITHOUT (36N).
- ④ SWITCHES SHOWN WITHOUT WIRE ASM-HOUSING CONNECTED.
- ③ SAME FOR ALL DASH SWITCHES EXCEPT FOG LAMPS, DOCKING LAMPS AND GENERATOR SWITCHES.
- ② SAME FOR ALL SWITCHES.
- ① CHASSIS SUPPLIED.

- (57M) LAMPS-FOG
- (36D) AIR HORNS-CHROME
- (36N) FANS-DEFROSTER, AUXILIARY
- (WIN) WINNEBAGO ONLY
- (ITA) ITASCA ONLY

(ITA)(WIN) 00 P-SERIES

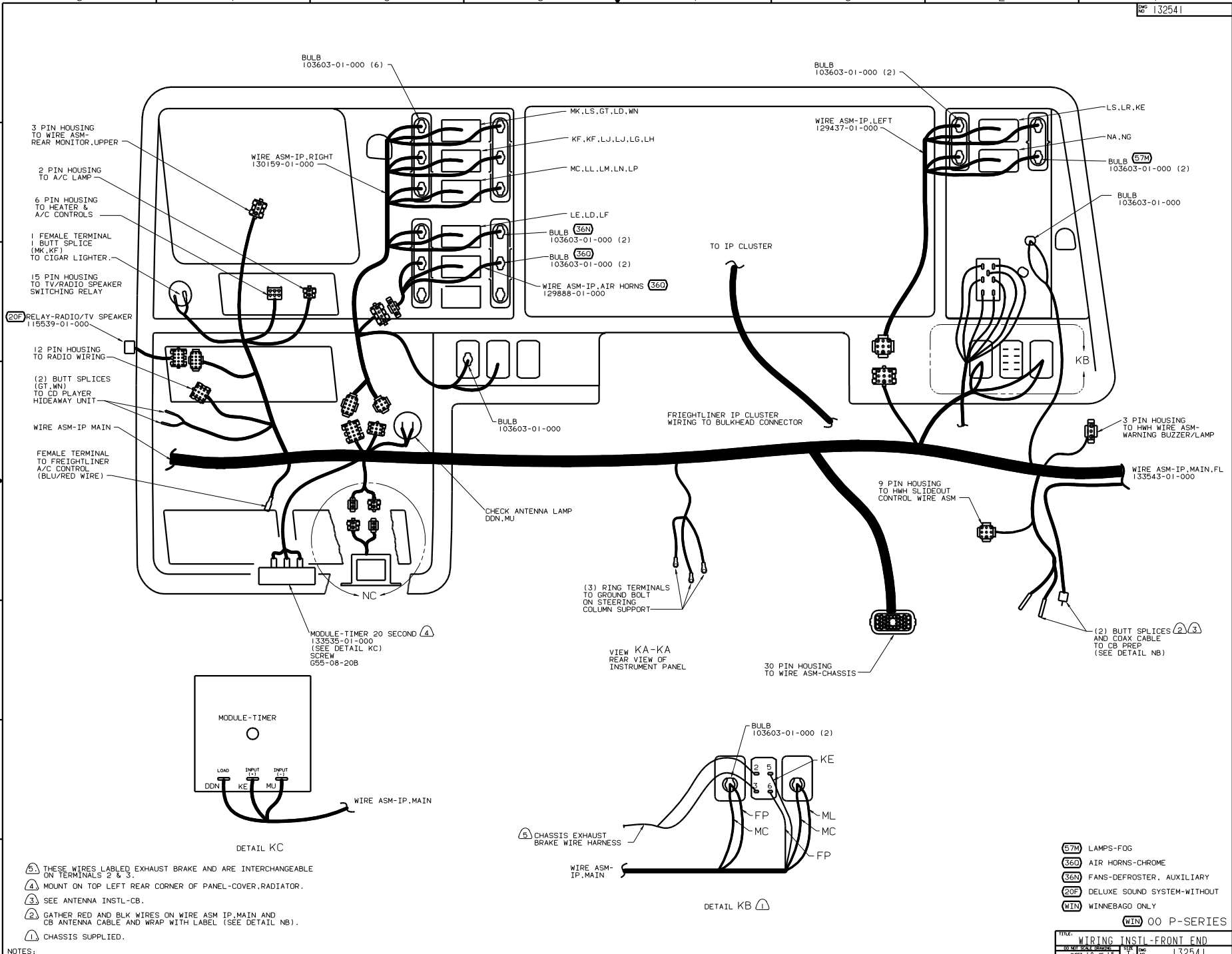

- NOTES:
- Ⓐ THESE WIRES LABELED EXHAUST BRAKE AND ARE INTERCHANGEABLE ON TERMINALS 2 & 3.
 - Ⓐ MOUNT ON TOP LEFT REAR CORNER OF PANEL-COVER, RADIATOR.
 - Ⓐ SEE ANTENNA INSTL-CB.
 - Ⓐ GATHER RED AND BLK WIRES ON WIRE ASM IP, MAIN AND CB ANTENNA CABLE AND WRAP WITH LABEL (SEE DETAIL NB).
 - Ⓐ CHASSIS SUPPLIED.

- Ⓐ LAMPS-FOG
- Ⓐ AIR HORNS-CHROME
- Ⓐ FANS-DEFROSTER, AUXILIARY
- Ⓐ DELUXE SOUND SYSTEM-WITHOUT
- Ⓐ WINNEBAGO ONLY

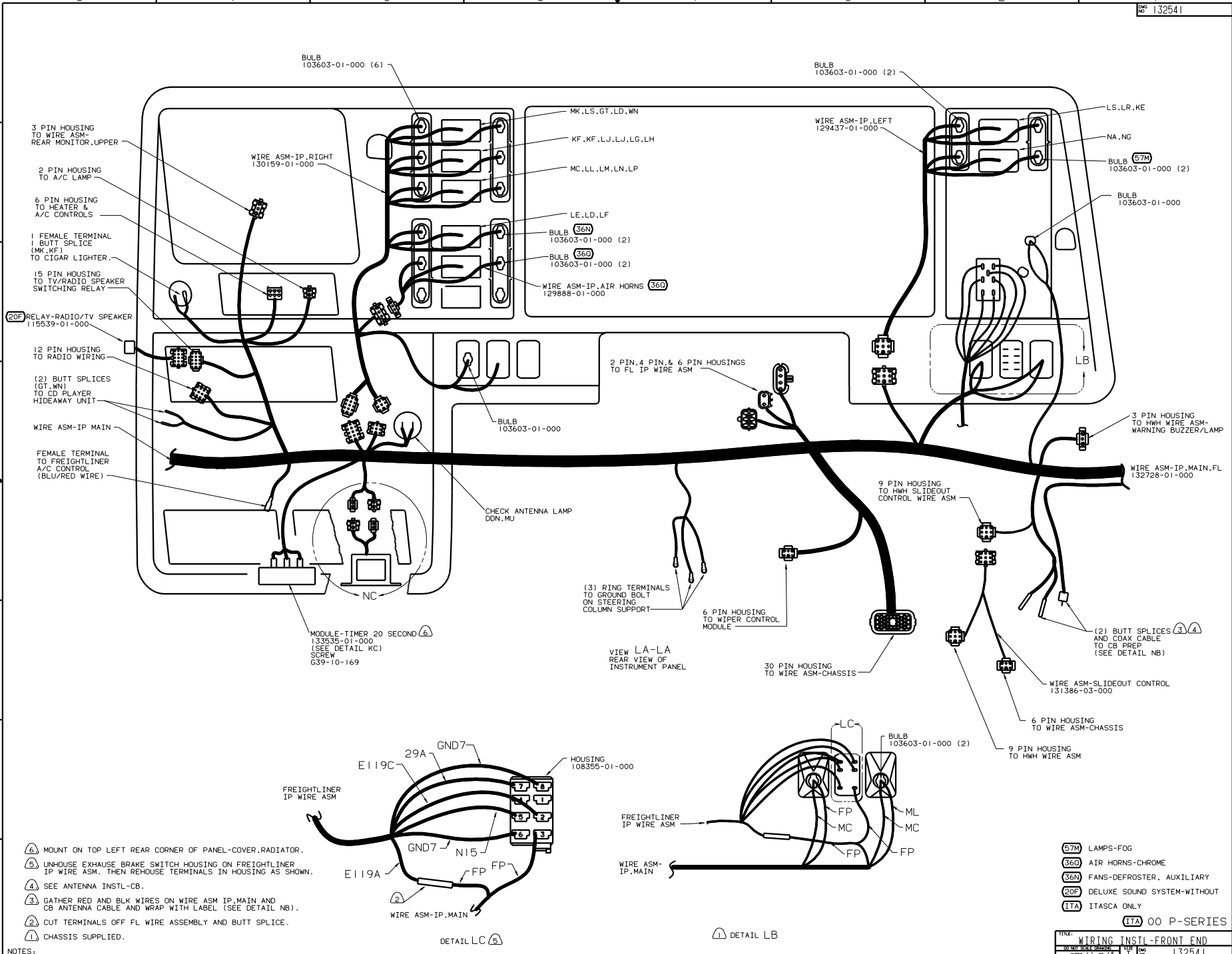

- Ⓐ MOUNT ON TOP LEFT REAR CORNER OF PANEL-COVER, RADIATOR.
- Ⓑ UNHOUSE EXHAUSE BRAKE SWITCH HOUSING ON FREIGHTLINER IP WIRE ASM. THEN REHOUSE TERMINALS IN HOUSING AS SHOWN.
- Ⓒ SEE ANTENNA INSTL-CB.
- Ⓓ GATHER RED AND BLK WIRES ON WIRE ASM IP, MAIN AND CB ANTENNA CABLE AND WRAP WITH LABEL (SEE DETAIL NB).
- Ⓔ CUT TERMINALS OFF FL WIRE ASSEMBLY AND BUTT SPLICE.
- Ⓕ CHASSIS SUPPLIED.

- Ⓔ LAMPS-FOG
- Ⓕ AIR HORNS-CHROME
- Ⓖ FANS-DEFROSTER, AUXILIARY
- Ⓗ DELUXE SOUND SYSTEM-WITHOUT
- Ⓘ ITASCA ONLY

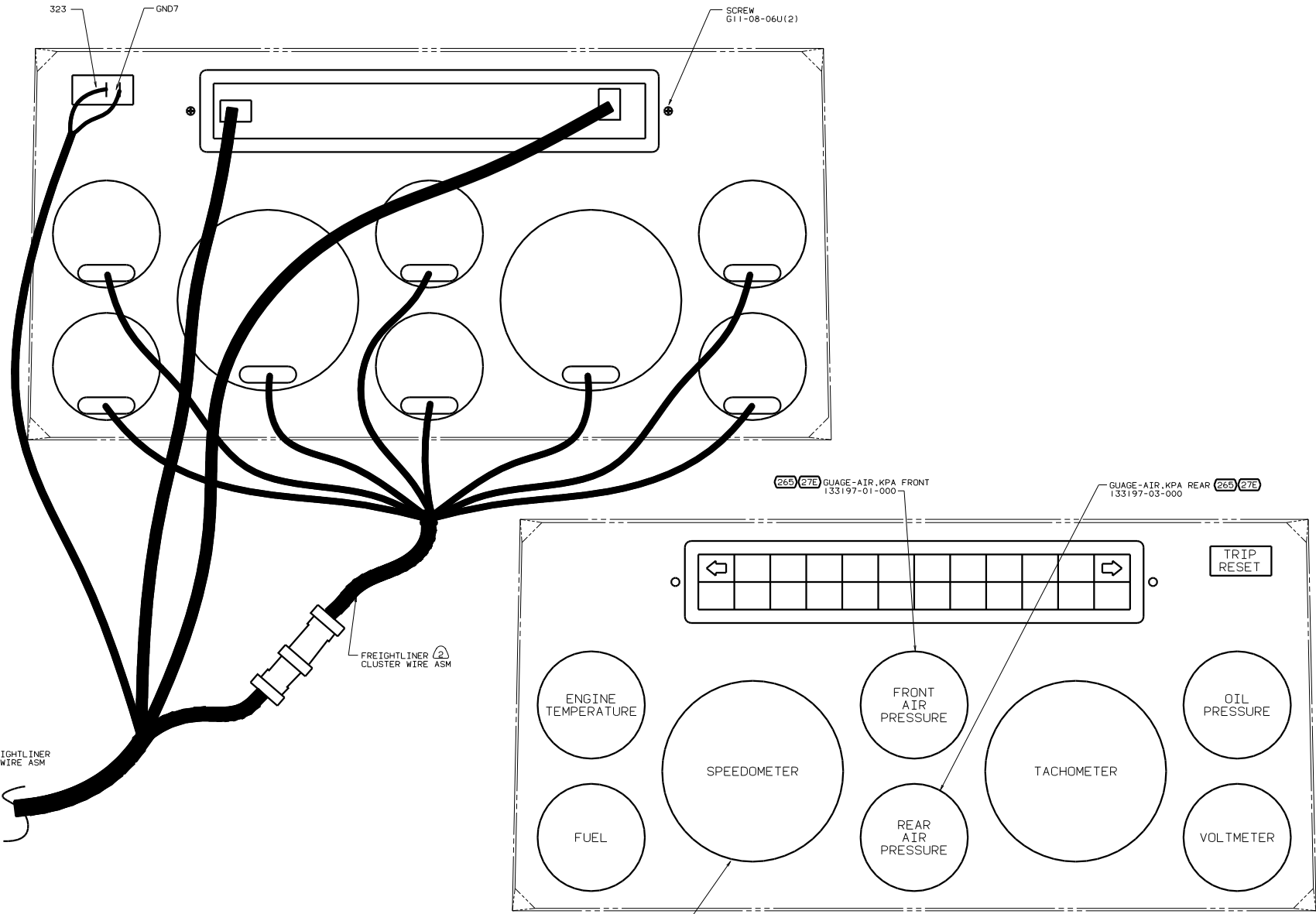

② ANY PLUG ON CLUSTER WIRE ASM WILL FIT ANY GAUGE
 1. ALL GAUGES, RETAINER CLIPS AND FASTENERS ARE CHASSIS SUPPLIED UNLESS NOTED.

DETAIL MA

- ②E CODES/STANDARDS-CMVSS
- ②65 CODES/STANDARDS-CSA/CMVSS
- ②TA ITASCA ONLY

②TA 00 P-SERIES

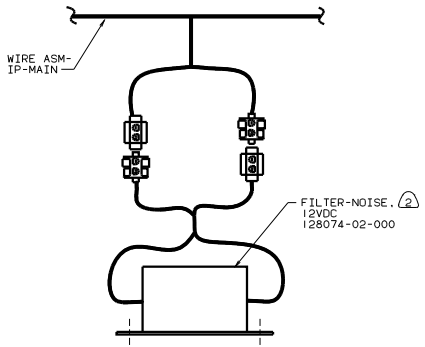
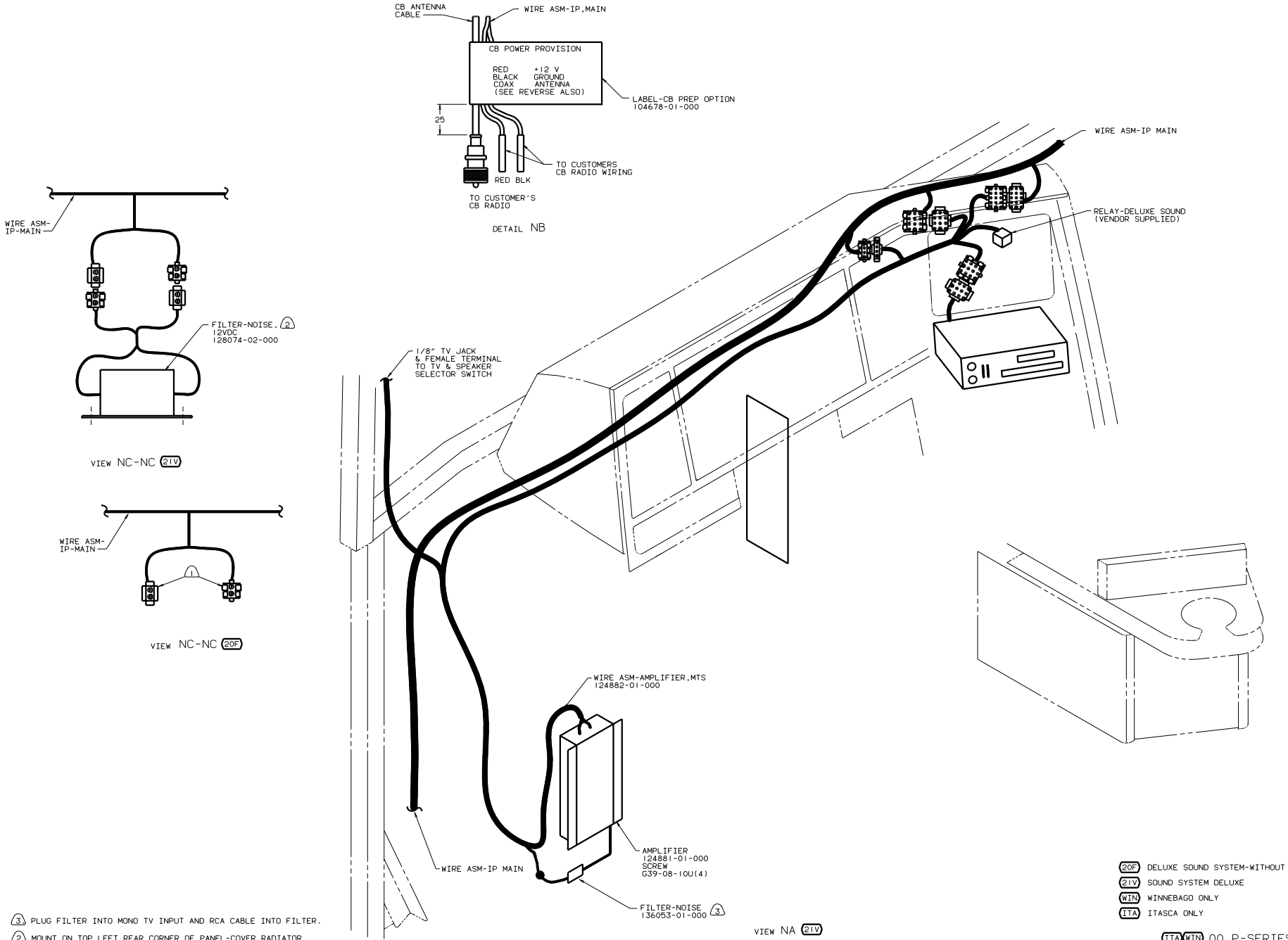

FILTER-NOISE (2)
12VDC
128074-02-000

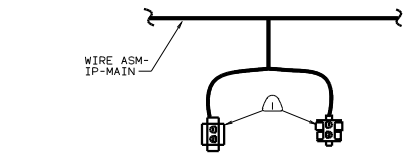

VIEW NC-NC (20F)

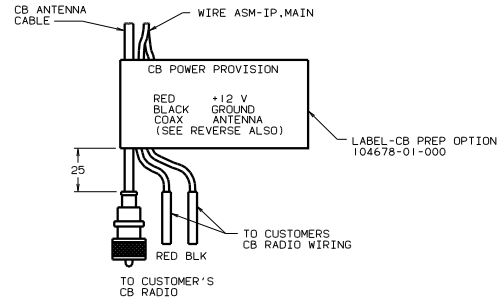

DETAIL NB

1/8" TV JACK & FEMALE TERMINAL TO TV & SPEAKER SELECTOR SWITCH

WIRE ASM-AMPLIFIER, MTS
124882-01-000

AMPLIFIER
124881-01-000
SCREW
G39-08-10U(4)

FILTER-NOISE
136053-01-000

- (20F) DELUXE SOUND SYSTEM-WITHOUT
- (21V) SOUND SYSTEM DELUXE
- (WIN) WINNEBAGO ONLY
- (ITA) ITASCA ONLY

VIEW NA (21V)

- NOTES:
- (3) PLUG FILTER INTO MONO TV INPUT AND RCA CABLE INTO FILTER.
 - (2) MOUNT ON TOP LEFT REAR CORNER OF PANEL-COVER, RADIATOR.
 - (1) CONNECT HOUSINGS TOGETHER.

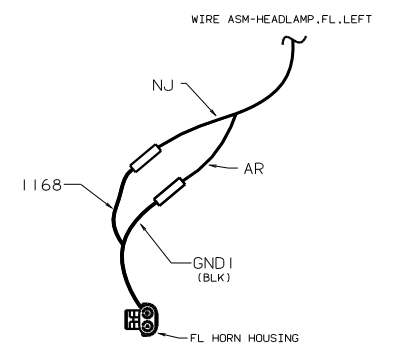
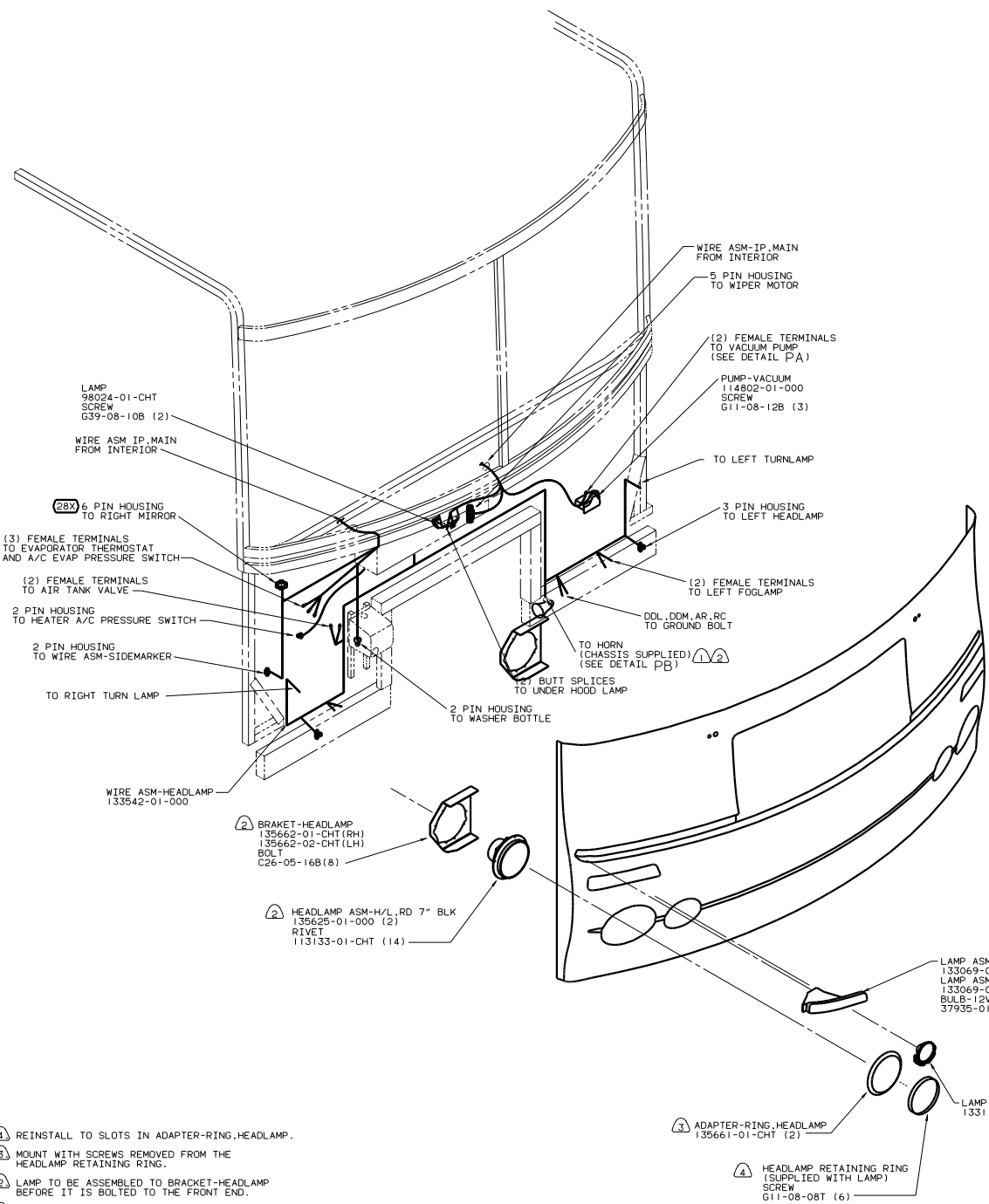

DETAIL PB

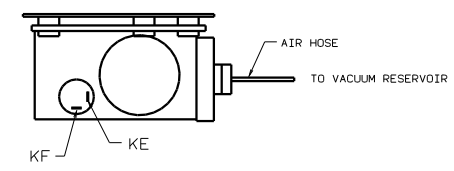

VIEW PA-PA

- (4) REINSTALL TO SLOTS IN ADAPTER-RING, HEADLAMP.
- (3) MOUNT WITH SCREWS REMOVED FROM THE HEADLAMP RETAINING RING.
- (2) LAMP TO BE ASSEMBLED TO BRACKET-HEADLAMP BEFORE IT IS BOLTED TO THE FRONT END.
- (1) MOUNT ON GROUND BOLT.

(28X) MIRRORS-EXTERIOR W/DEFROST

(WIN) WINNEBAGO ONLY

(WIN) 00 P-SERIES

TITLE		WIRING INSTL-FRONT END	
30 THE SCALE SHOWN	FIG	16	NO
SHEET 14 OF 15	FIG	16	NO

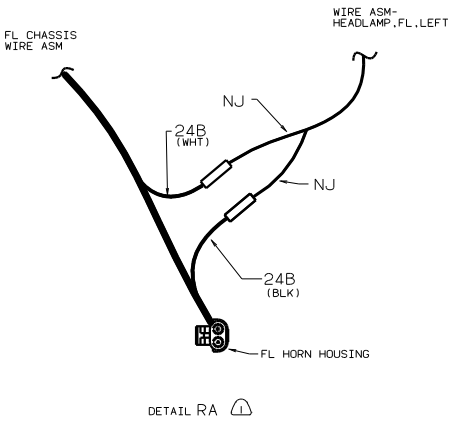
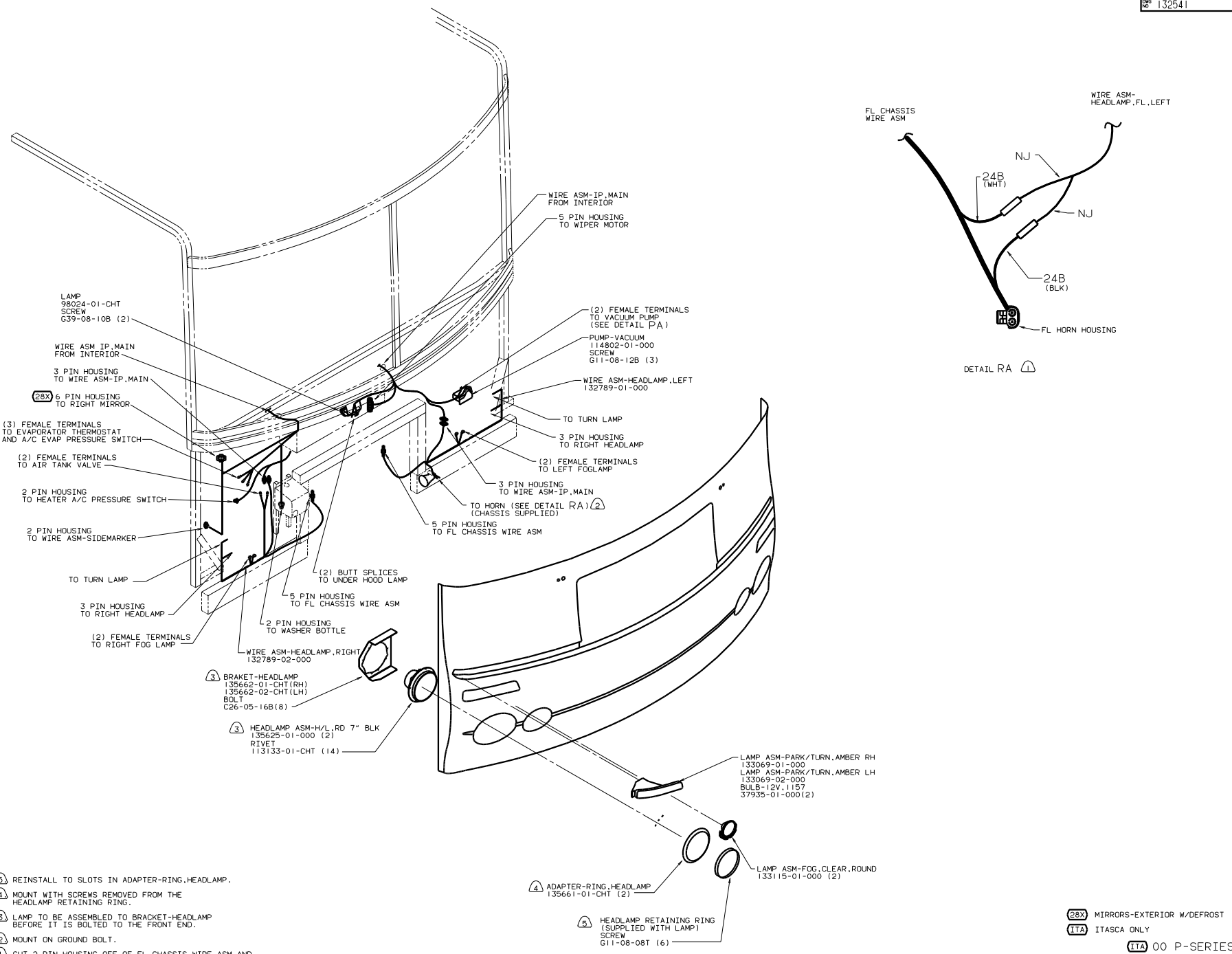

- ⑤ REINSTALL TO SLOTS IN ADAPTER-RING, HEADLAMP.
- ④ MOUNT WITH SCREWS REMOVED FROM THE HEADLAMP RETAINING RING.
- ③ LAMP TO BE ASSEMBLED TO BRACKET-HEADLAMP BEFORE IT IS BOLTED TO THE FRONT END.
- ② MOUNT ON GROUND BOLT.
- ① CUT 2 PIN HOUSING OFF OF FL CHASSIS WIRE ASM AND REUSE ON WIRE ASM-HEADLAMP, FL, LEFT

- ④ ADAPTER-RING, HEADLAMP 135661-01-CHT (2)
- ⑤ HEADLAMP RETAINING RING (SUPPLIED WITH LAMP) SCREW G11-08-08T (6)
- LAMP ASM-PARK/TURN, AMBER RH 133069-01-000
- LAMP ASM-PARK/TURN, AMBER LH 133069-02-000
- BULB-12V, 1157 37935-01-000(2)
- LAMP ASM-FOG, CLEAR, ROUND 133115-01-000 (2)

(28X) MIRRORS-EXTERIOR W/DEFROST
 (ITA) ITASCA ONLY
 (ITA) 00 P-SERIES