



**DANGER**

**Danger of electrical shock, burns or death.** Always remove all power sources before attempting any repair, service or diagnostic work. Power can be present from shore power, generator, inverter or battery. All power sources must be disabled and secured before performing any service.



**CAUTION**

If you lack the skills, tools or equipment to perform diagnostic or repair work leave such work to an authorized Winnebago Industries dealer or other qualified shop.

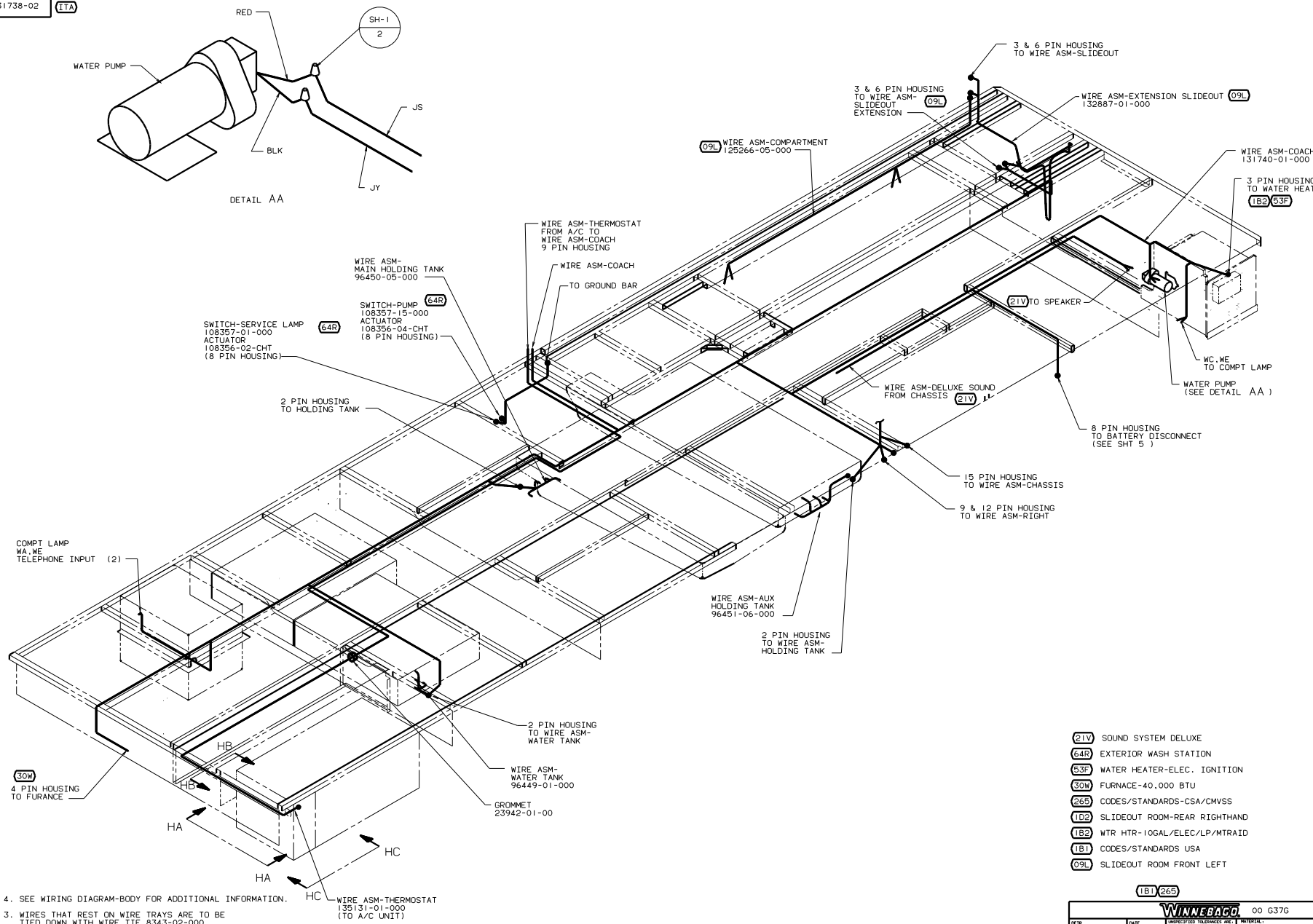

4. SEE WIRING DIAGRAM-BODY FOR ADDITIONAL INFORMATION.
3. WIRES THAT REST ON WIRE TRAYS ARE TO BE TIED DOWN WITH WIRE TIE 8343-02-000
2. CLAMP TO FLOOR SUPPORT TUBES AS NECESSARY WITH CLAMP 10497-01-000
1. ALL WIRE TO BE CLAMPED WITH CLAMP 10495-01-000 OR CLIP 80734-02-000 EVERY 600. USE SCREW G67-10-12B UNLESS OTHERWISE SPECIFIED.

NOTES:

- (21V) SOUND SYSTEM DELUXE
- (64R) EXTERIOR WASH STATION
- (63F) WATER HEATER-ELEC. IGNITION
- (30W) FURNACE-40,000 BTU
- (265) CODES/STANDARDS-CSA/CMVSS
- (1B2) SLIDEOUT ROOM-REAR RIGHTHAND
- (1B2) WTR HTR-10GAL/ELEC/LP/MTRAIID
- (1B1) CODES/STANDARDS USA
- (09L) SLIDEOUT ROOM FRONT LEFT

(1B1) 265

FOR ELECTRICAL TORQUE SPECIFICATIONS SEE DWG NO. 128783-01-000

FOR ELECTRICAL CALLOUTS SEE DWG NO. 121339-01-000

<b>WINNEBAGO</b>		00 G37G
OF IN	DATE	UNSPECIFIED TOLERANCES ARE:
CHP	DATE	WHOLE DIM (IN) . . . . .
PIE	DATE	ONE-PLACE (IN.XI) . . . . .
D/E	DATE	TWO-PLACE (IN.XXX) . . . . .
CONP	DATE	THIRD-PLACE (IN.XXXX) . . . . .
DATE	DATE	INDICATE W/ANGLE PROJECTION
SHEET NO. <b>WIRING INSTL-BODY 12V (RF)</b> OF 9 SCALE: NONE TITLE: WIRING INSTL-BODY 12V (RF) DWG NO. 131738 ALL DIMENSIONS ARE IN MILLIMETERS SHEET 1 OF 9 1:1		MATERIAL: 131738

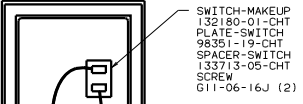
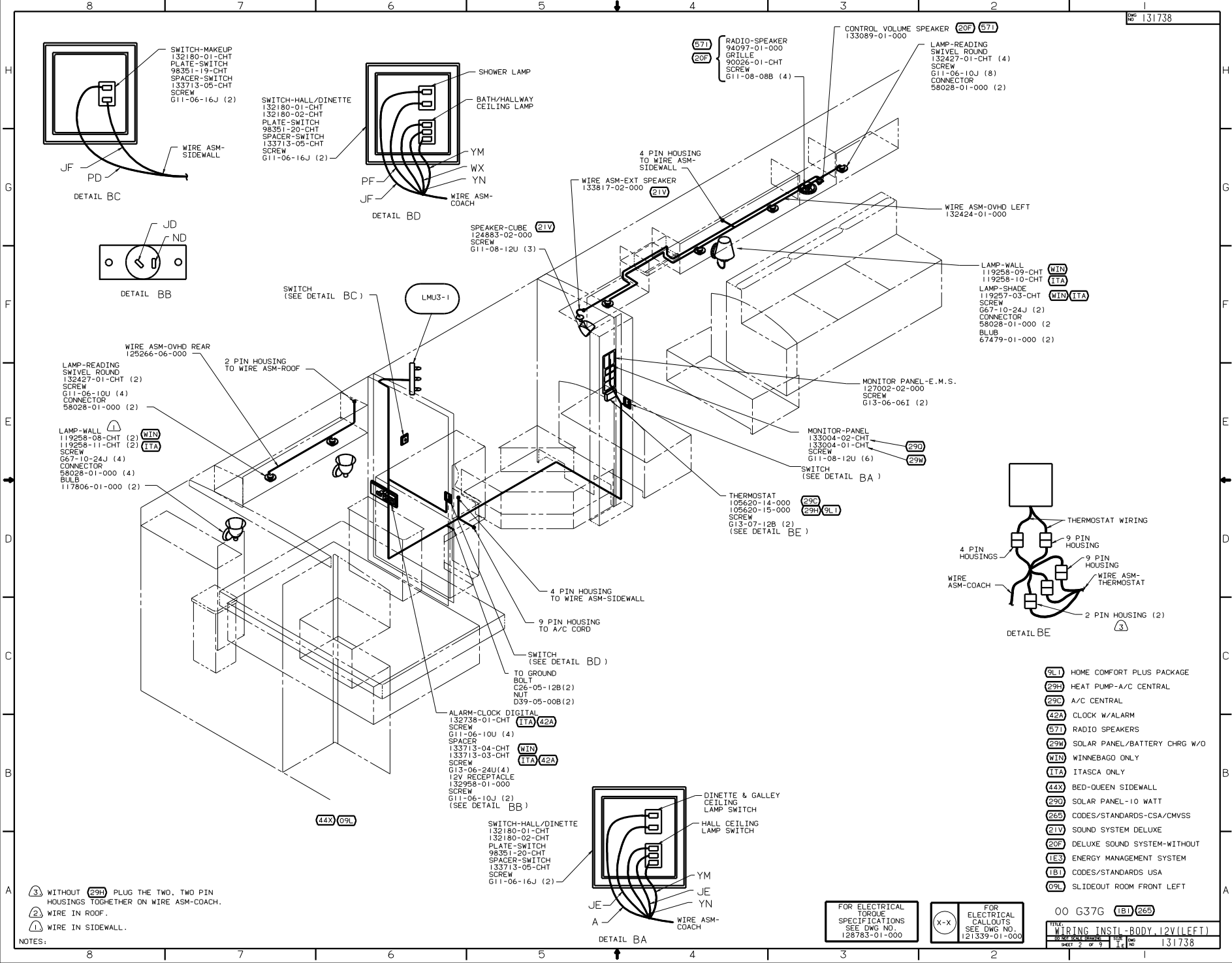

DETAIL BC

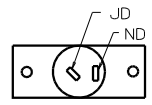

DETAIL BB

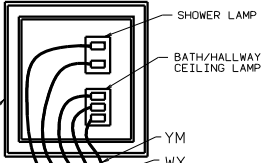

DETAIL BD

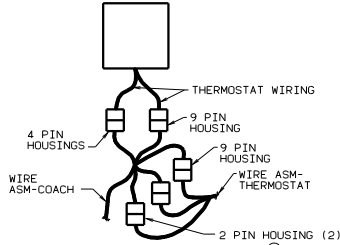
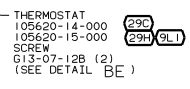
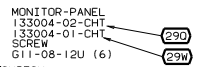
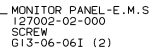
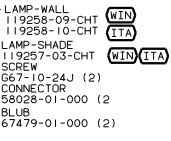
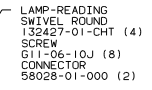
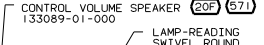
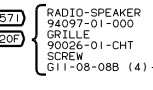
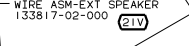
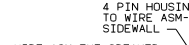
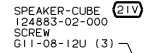
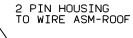
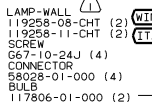
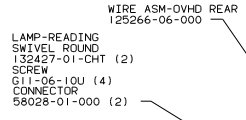

DETAIL BE

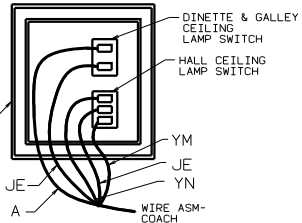
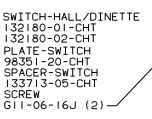
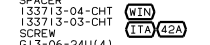
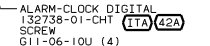
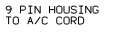
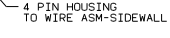

DETAIL BA

- 9L1 HOME COMFORT PLUS PACKAGE
- 23H HEAT PUMP-A/C CENTRAL
- 29C A/C CENTRAL
- 42A CLOCK W/ALARM
- 571 RADIO SPEAKERS
- 29W SOLAR PANEL/BATTERY CHRG W/O
- WIN WINNEBAGO ONLY
- ITA ITASCA ONLY
- 44X BED-QUEEN SIDEWALL
- 29D SOLAR PANEL-10 WATT
- 26S CODES/STANDARDS-CSA/CMVSS
- 21V SOUND SYSTEM DELUXE
- 20F DELUXE SOUND SYSTEM-WITHOUT
- 1ES ENERGY MANAGEMENT SYSTEM
- 1B1 CODES/STANDARDS USA
- 09L SLIDEOUT ROOM FRONT LEFT

NOTES:  
 (3) WITHOUT (29H) PLUG THE TWO, TWO PIN HOUSINGS TOGETHER ON WIRE ASM-COACH.  
 (2) WIRE IN ROOF.  
 (1) WIRE IN SIDEWALL.

FOR ELECTRICAL TORQUE SPECIFICATIONS SEE DWG NO. 128783-01-000

FOR ELECTRICAL CALLOUTS SEE DWG NO. 121339-01-000

00 G37G (1B1) (26S)  
 WIRING INSTL - BODY, 12V (LEFT)  
 SHEET 2 OF 3  
 131738



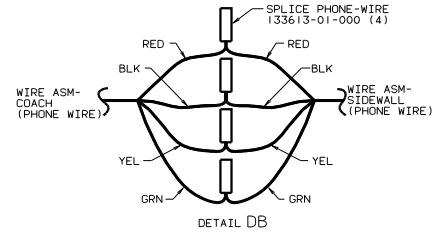
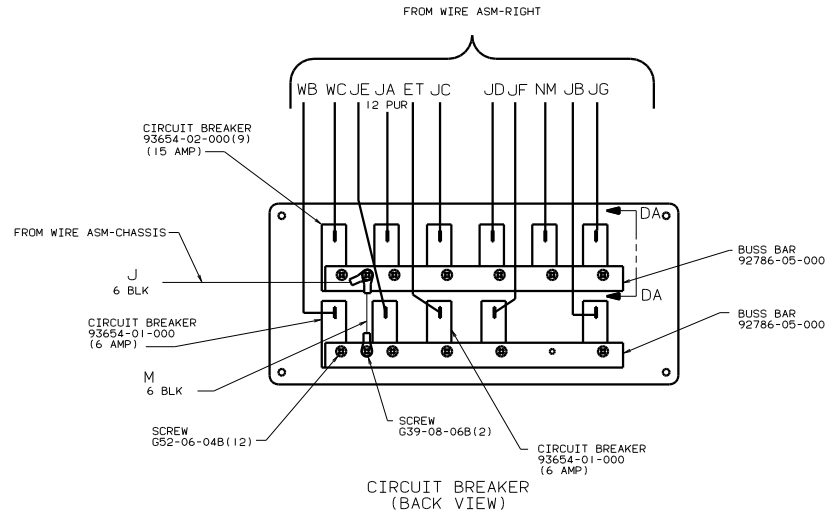
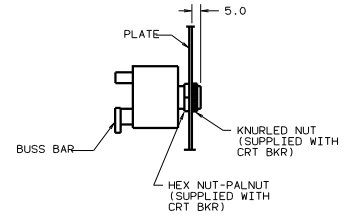
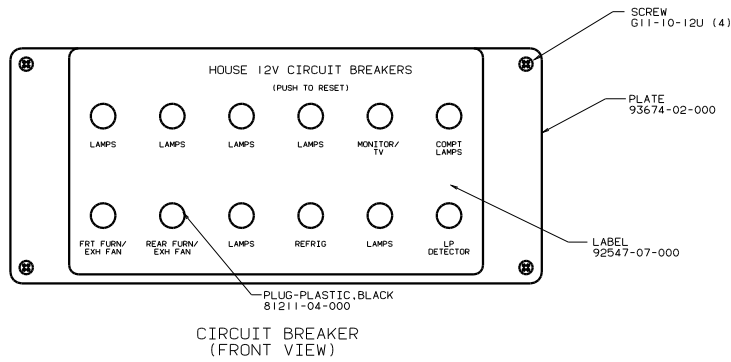

NOTES:

FOR ELECTRICAL TORQUE SPECIFICATIONS SEE DWG NO. 128783-01-000

(265) CODES/STANDARDS-CSA/CMVSS  
(1B1) CODES/STANDARDS USA  
00 G37G (1B1)

TITLE: WIRING INSTL-BODY(12 BP)	
NO. OF SHEETS: 3	TOT. SHEETS: 3
SHEET: 4 OF 3	FIG. NO. 131738

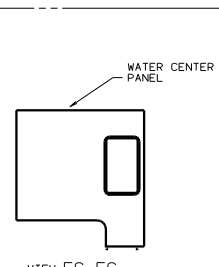
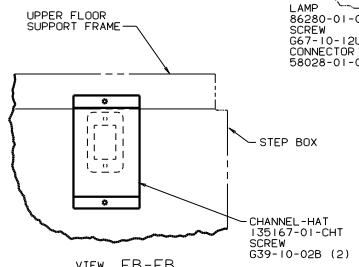
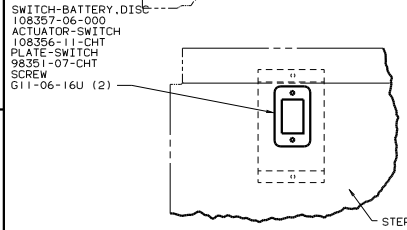
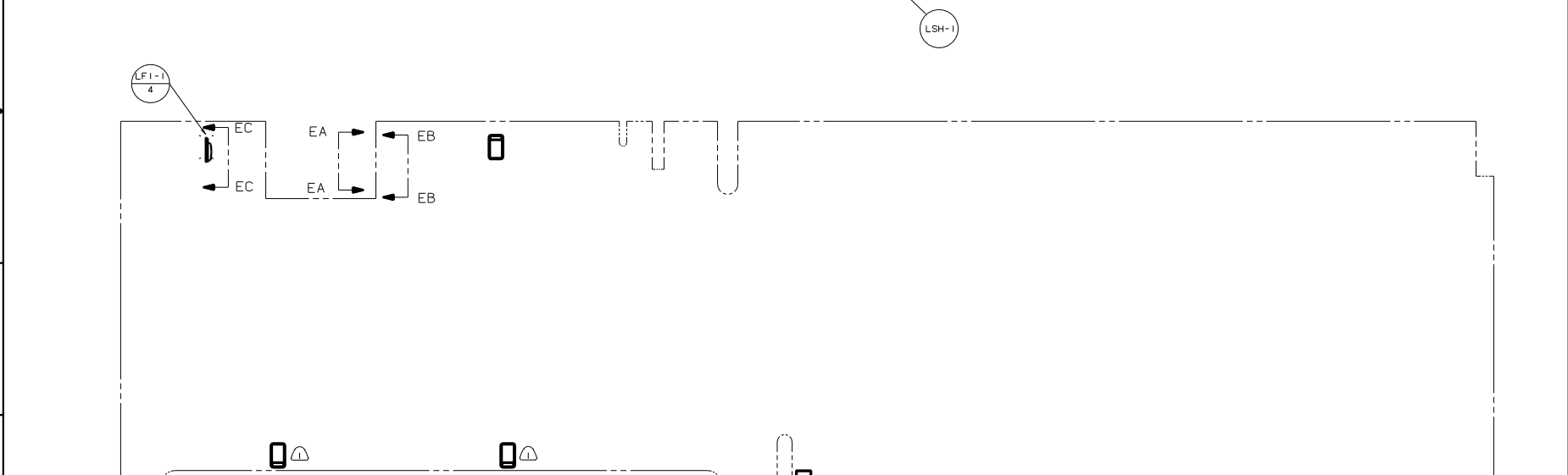
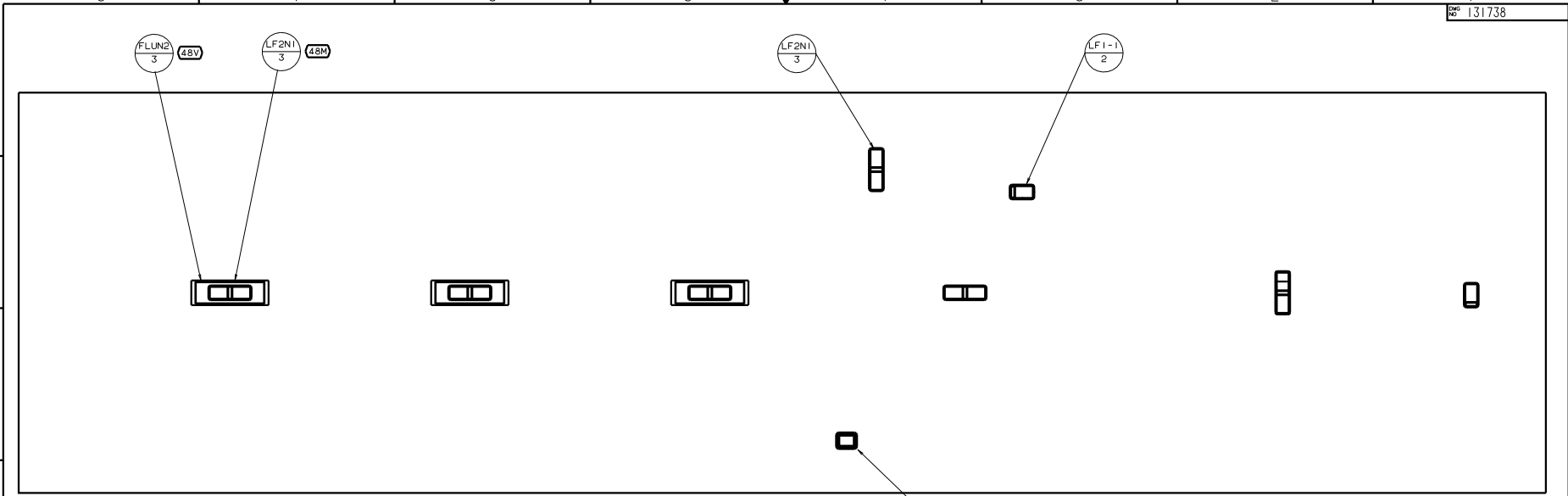

NOTES:  
 1) LAMPS LOCATED IN SLIDEOUT COMPARTMENTS. VIEW EA-EA

VIEW EB-EB

VIEW EC-EC

- (48V) LIGHTS-FLUORESCENT
- (48M) LIGHTS-INCANDESCENT
- (265) CODES/STANDARDS-CSA/CMVSS
- (1B1) CODES/STANDARDS-USA

FOR ELECTRICAL TORQUE SPECIFICATIONS SEE DWG NO. 128783-01-000

FOR ELECTRICAL CALLOUTS SEE DWG NO. 121339-01-000

TITLE: WIRING INSTL-BODY,12V (CL)  
 SHEET 5 OF 9  
 DWG NO 131738

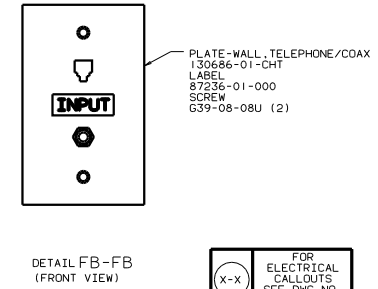
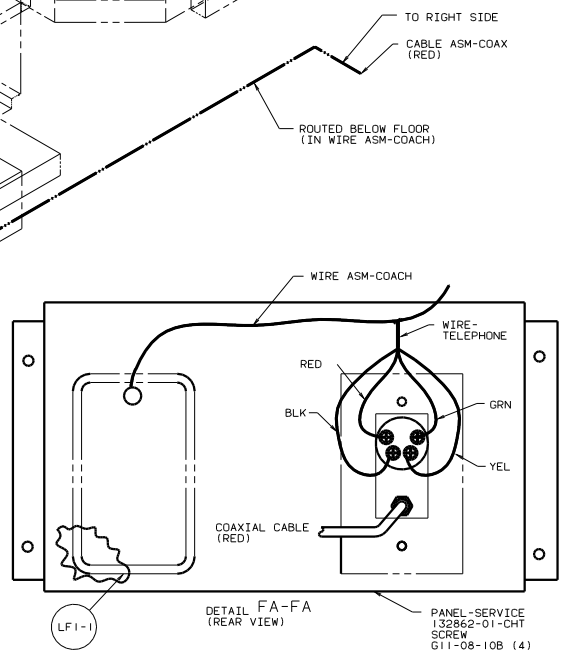
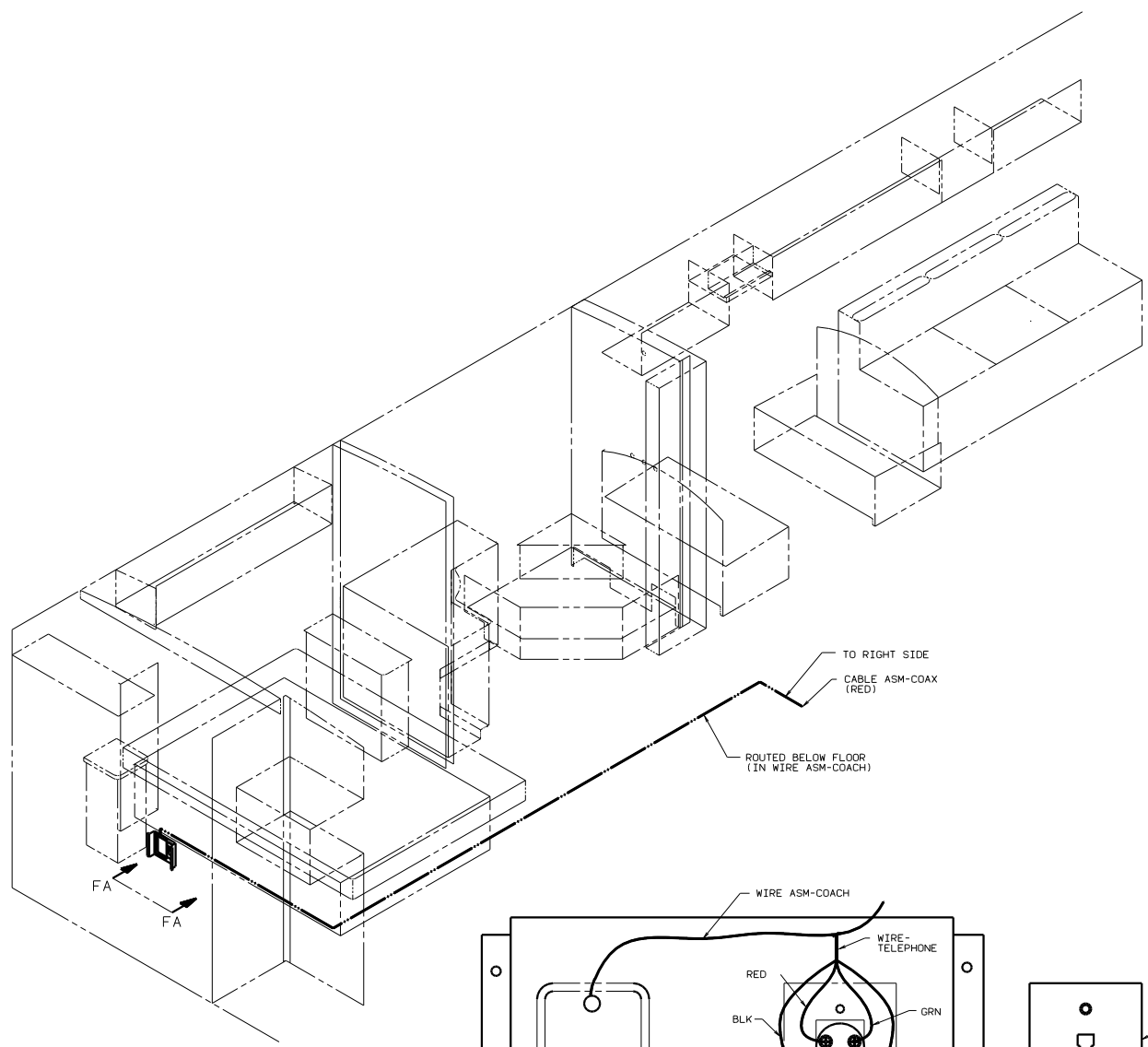

FOR ELECTRICAL CALLOUTS SEE DWG NO. 121339-01-000

(265) CODES/STANDARDS-CSA/CMVSS  
 (1B1) CODES/STANDARDS USA  
 00 G37G (1B1) (265)  
 TITLE: WIRING INSTL-BODY,12V (L COAX)  
 SHEET 6 OF 9  
 131738

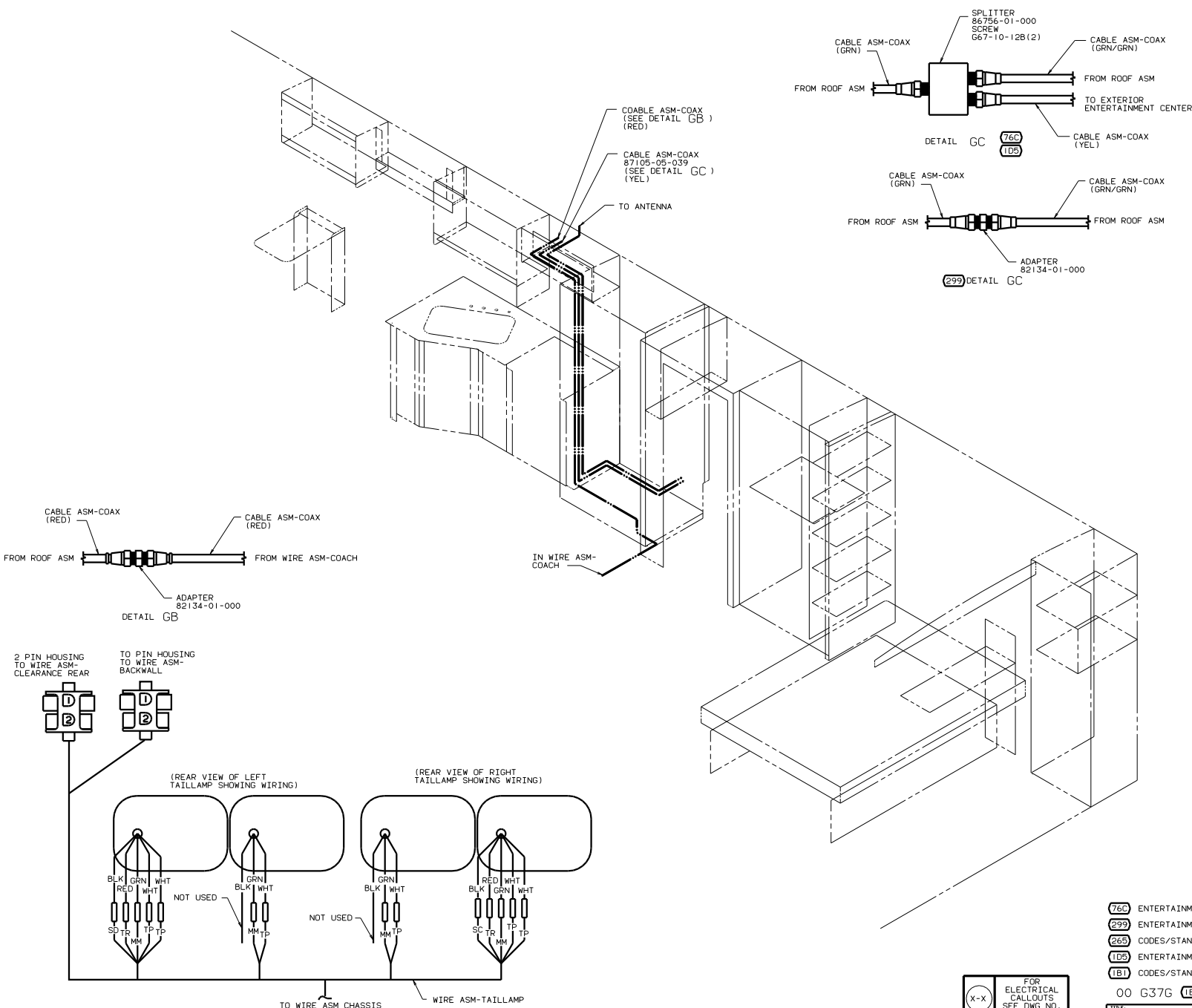

- 76C ENTERTAINMNT CTR/EXT CASSETTE
- 299 ENTERTAINMNT CENTER EXT. W/O
- 265 CODES/STANDARDS-CSA/CMVSS
- 1D5 ENTERTAINMENT CNTR/EXT W/CD
- 1B1 CODES/STANDARDS USA

(X-X) FOR ELECTRICAL CALLOUTS SEE DWG NO. 121339-01-000



GROMMET  
23942-01-000

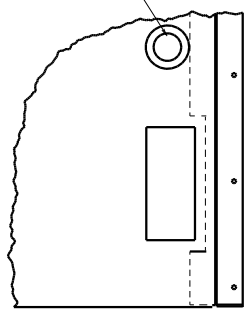

VIEW HB-HB

WIRE ASM-THERMOSTAT  
(COIL UP AND TIE EXCESS  
WIRE IN BASEMENT AREA  
WITH WIRE TIE 8343-02-000)

TO THERMOSTAT

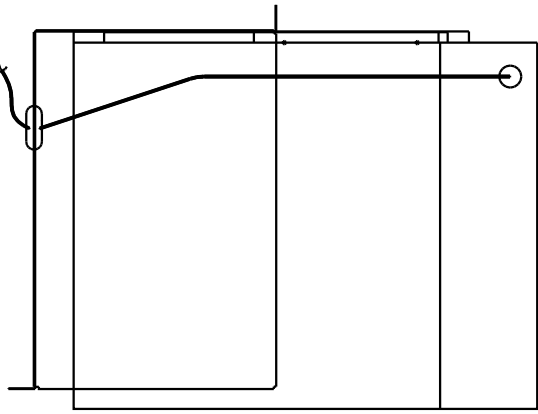

VIEW HA-HA

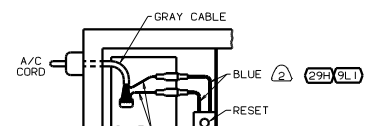

VIEW HC-HC

WHITE BLACK WHITE BLACK  
CIRCUIT 1 CIRCUIT 2

- NOTES:
- (2) CONNECT BLUE WIRES FROM RESET TO THE BLUE WIRES WITH SPADE TERMINALS ON A/C CORD WITH (29H) & (9L1) FEATURE
  - (1) SEE WIRING INSTL-BODY, 110V FOR ADDITIONAL INFORMATION.

- (9L1) HOME COMFORT PLUS PACKAGE
- (29H) HEAT PUMP-A/C CENTRAL
- (265) CODES/STANDARDS-CSA/CMVSS
- (1B1) CODES/STANDARDS USA

00 G37G (1B1)

WIRING INSTL-BODY, 12V(C-A/C)	
DATE	REV
0000000000	1.0
SHEET 8 OF 9	DWG NO 131738

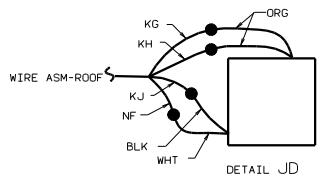
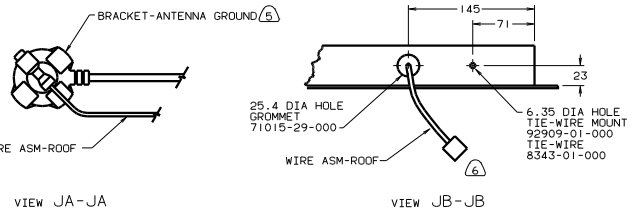

- (1B1) LAMP 97917-01-CHT
- (1B1) SCREW G67-10-12U(EXT) (4)
- (265) LAMP 8089-02-000
- (265) SCREW G67-06-10T(EXT) (2)
- (265) CONNECTOR 58028-01-000 (2)
- SEAL

- LAMP-CLEARANCE, RED 133055-01-000 (5)
- SCREW G39-08-16T (EXT) (10)
- BASE 133055-03-000 (5)
- BULB 36196-01-000 (5)

- LAMP ASM-BRAKE 121950-01-000
- SCREW (SUPPLIED W/LAMP)

- LAMP-MARKER, BASE 111102-01-000 (2)
- LAMP-MARKER, LENS, RED 111102-03-000 (2)
- SCREW G39-08-12U(EXT) (4)

- LAMP-LICENSE 87201-01-000
- SCREW G11-06-12U(EXT) (2)

- (6) FASTEN TO VENT.
- (5) WRAP BRACKET LEGS AROUND ANTENNA BASE.
- (4) CONNECTOR-PLUG, TRAILER (113589-01-000) TO BE SUPPLIED LOOSE IN COACH WITH TRAILER TOW PACKAGE.
- (3) CLAMP WIRES ABOVE TAILLAMP POD.
- (2) SEE DWG 76319-01-000 FOR INSTALLATION OF TV ANTENNA.
- (1) INSTALL WITH WIRES TOWARDS ROOF.

- (7) ADD RUBBER BUMPERS TO ROOF UNDER EACH END OF ANTENNA TO PREVENT CONTACT WITH ROOF.

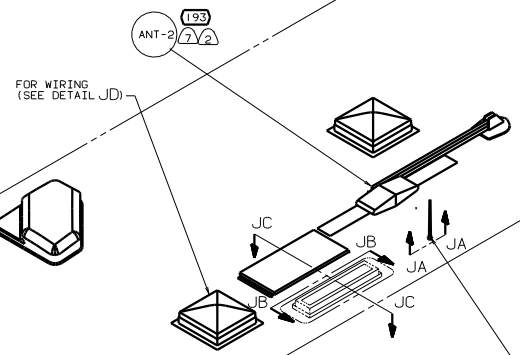

- DM-1 (480)
- WIRE ASM-CLEARANCE LAMPS 126486-01-000
- LAMP-CLEARANCE AMBER 192578-01-000 (5) (WIN) (ITA)
- SCREW G39-08-16T (EXT) (10) (WIN) (ITA)
- GASKET 102541-01-000 (5) (WIN)
- BULBS 36196-01-000 (5) (WIN) (ITA)
- CONNECTS TO WIRE ASM-IP, MAIN

- LAMP-MARKER, BASE 111102-01-000 (2)
- LAMP-MARKER, LENS, AMBER 111102-02-000 (2)
- RIVET 118626-02-CHT

- LAMP (1B1) 97917-01-CHT
- (1B1) SCREW G67-10-12U(EXT) (4)
- (265) LAMP 8089-02-000
- (265) SCREW G67-06-10T(EXT) (2)
- (265) CONNECTOR 58028-01-000 (2)
- SEAL

- ANTENNA-SHAFT EXTENDER 109889-04-000
- BRACKET-ANTENNA GROUND 108847-01-000
- ANTENNA 90944-01-000
- CABLE-ANTENNA EXTENSION 77069-02-000
- SEAL
- (76C)
- (1D5)

- LAMP-MARKER, BASE 111102-01-000 (2)
- LAMP-MARKER, LENS, AMBER 111102-02-000 (2)
- SCREW G11-08-12U(EXT) (4)

- SOLAR PANEL (290) 115504-01-000
- SCREW G11-08-16U (4)

- WIRE ASM-CLEARANCE LAMPS, RR 132729-01-000

- LIGHT ASM-STOP/TURN/TAIL 115632-01-CHT (2)
- SCREW G11-08-12U (EXT) (8)

- LIGHT ASM-STOP/TAIL/BACKUP 115632-03-CHT (2)
- CONNECTOR 58028-01-000 (2)
- SCREW G11-08-12U (EXT) (8)

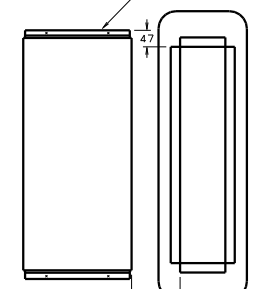

(X-X)

FOR ELECTRICAL CALLOUTS SEE DWG NO. 121339-01-000

- (WIN) WINNEBAGO ONLY
- (ITA) ITASCA ONLY
- (76C) ENTERTAINMENT CTR/EXT CSETTE
- (240) TRAILER HITCH
- (1D5) ENTERTAINMENT CTR-EXT-W/CD
- (193) TV ANTENNA
- (480) SATELLITE DISH
- (290) SOLAR PANEL - 10 WATT
- (265) CODES/STANDARDS-CSA/CMVSS
- (1B1) CODES STANDARDS/USA