



DANGER

Danger of electrical shock, burns or death. Always remove all power sources before attempting any repair, service or diagnostic work. Power can be present from shore power, generator, inverter or battery. All power sources must be disabled and secured before performing any service.



CAUTION

If you lack the skills, tools or equipment to perform diagnostic or repair work leave such work to an authorized Winnebago Industries dealer or other qualified shop.

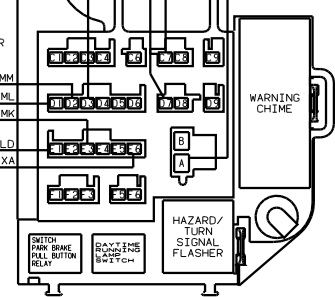
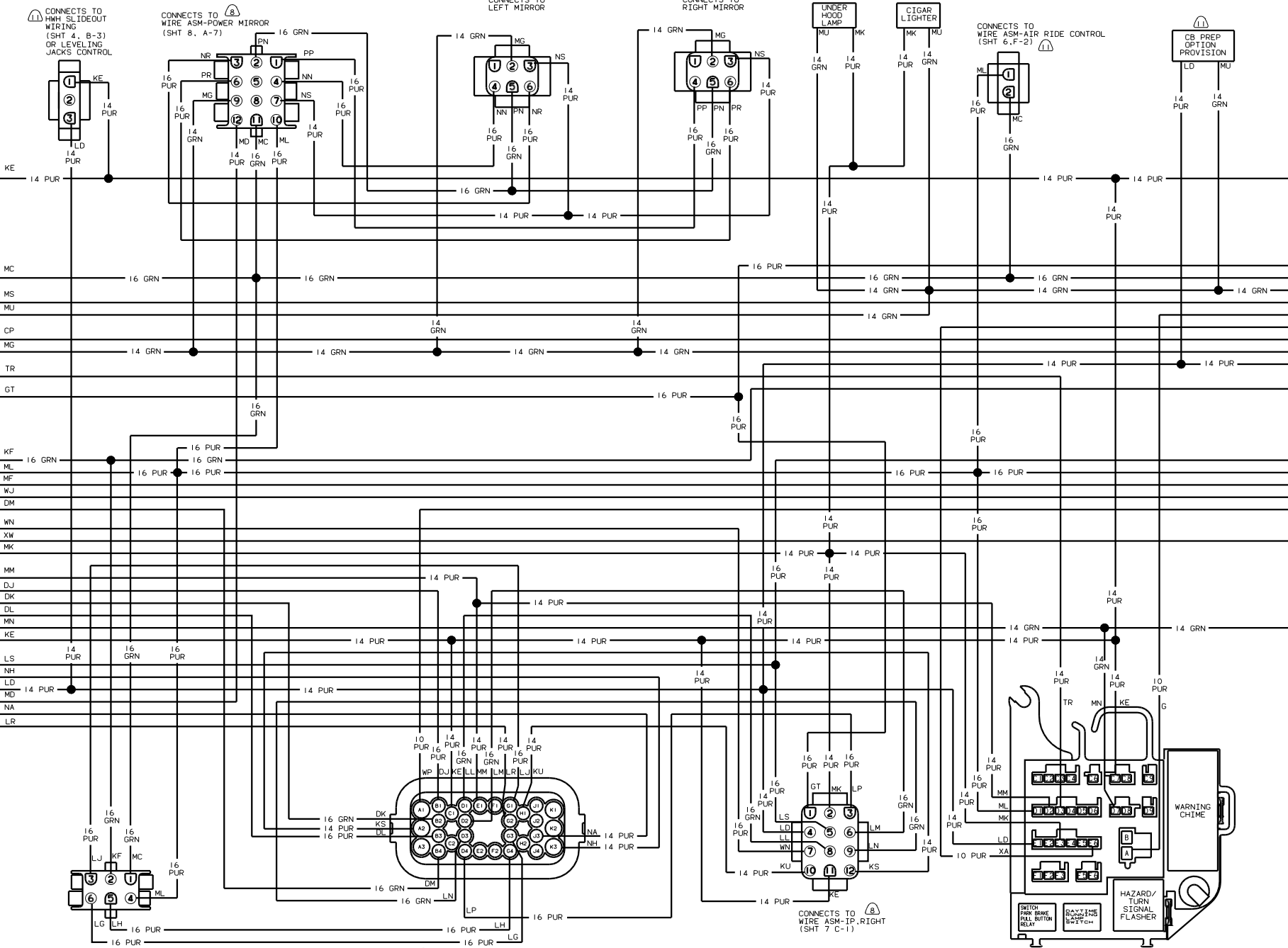

HD GM I/P CONVENIENCE CENTER (LOCATED ON BULKHEAD BELOW LEFT DASH)

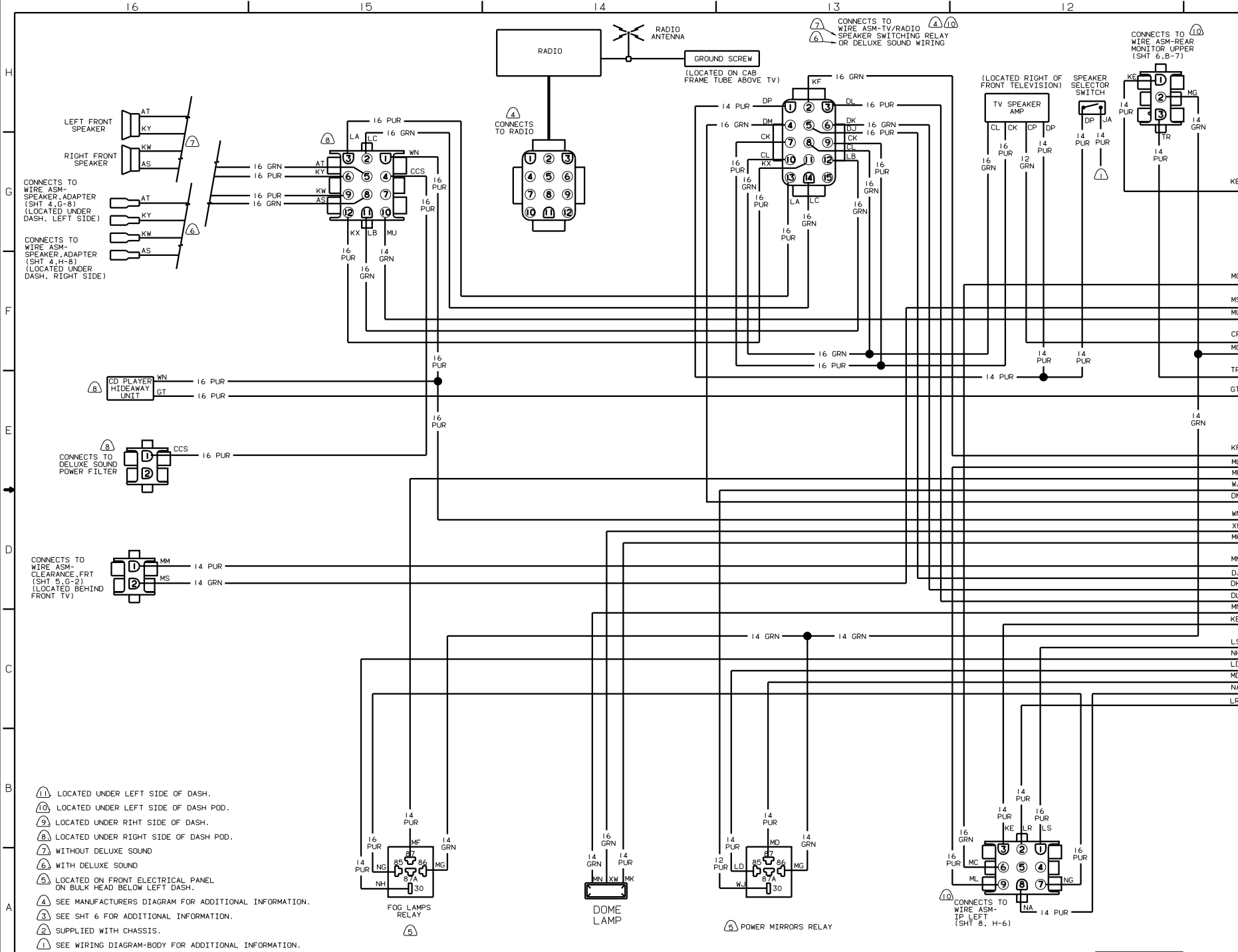

CONNECTS TO WIRE ASM- SPEAKER, ADAPTER (SHT 4,G-8) (LOCATED UNDER DASH, LEFT SIDE)

CONNECTS TO WIRE ASM- SPEAKER, ADAPTER (SHT 4,H-8) (LOCATED UNDER DASH, RIGHT SIDE)

CD PLAYER WIRE HIDEAWAY UNIT

CONNECTS TO DELUXE SOUND POWER FILTER

CONNECTS TO WIRE ASM- CLEARANCE, FRT (SHT 5,G-2) (LOCATED BEHIND FRONT TV)

- NOTES:
- ⑪ LOCATED UNDER LEFT SIDE OF DASH.
 - ⑩ LOCATED UNDER LEFT SIDE OF DASH POD.
 - ⑨ LOCATED UNDER RIHT SIDE OF DASH.
 - ⑧ LOCATED UNDER RIGHT SIDE OF DASH POD.
 - ⑦ WITHOUT DELUXE SOUND
 - ⑥ WITH DELUXE SOUND
 - ⑤ LOCATED ON FRONT ELECTRICAL PANEL ON BULK HEAD BELOW LEFT DASH.
 - ④ SEE MANUFACTURERS DIAGRAM FOR ADDITIONAL INFORMATION.
 - ③ SEE SHT 6 FOR ADDITIONAL INFORMATION.
 - ② SUPPLIED WITH CHASSIS.
 - ① SEE WIRING DIAGRAM-BODY FOR ADDITIONAL INFORMATION.

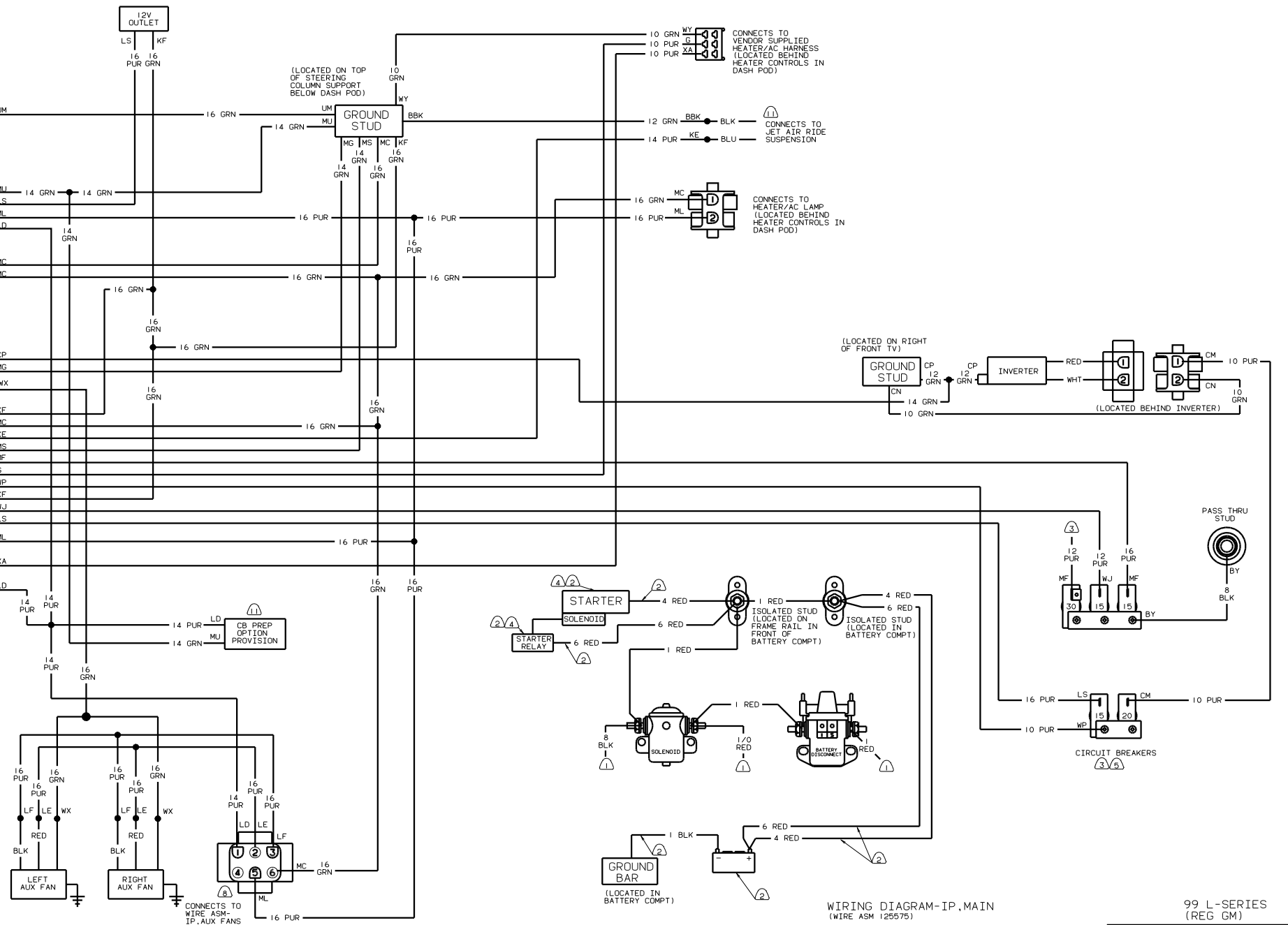

WIRING DIAGRAM-IP, MAIN (WIRE ASM 125575)

99 L-SERIES (REG GM)

TITLE: WIRING DIAGRAM-AUTO	
NO. OF SHEETS: 8	SHEET: 2 OF 8
REV. NO.:	131806

CONNECTS TO WHW SLIDEOUT WIRING (SHT 4, B-3) (OR LEVELING JACKS CONTROL)

CONNECTS TO WIRE ASM-IP, RIGHT (SHT 7, C-1)

CONNECTS TO LEFT MIRROR

CONNECTS TO RIGHT MIRROR

CONNECTS TO WIRE ASM-AIR RIDE CONTROL (SHT 6, F-2)

CONNECTS TO GM DOME LAMP CONNECTOR

DOOR DOME LAMP SWITCH

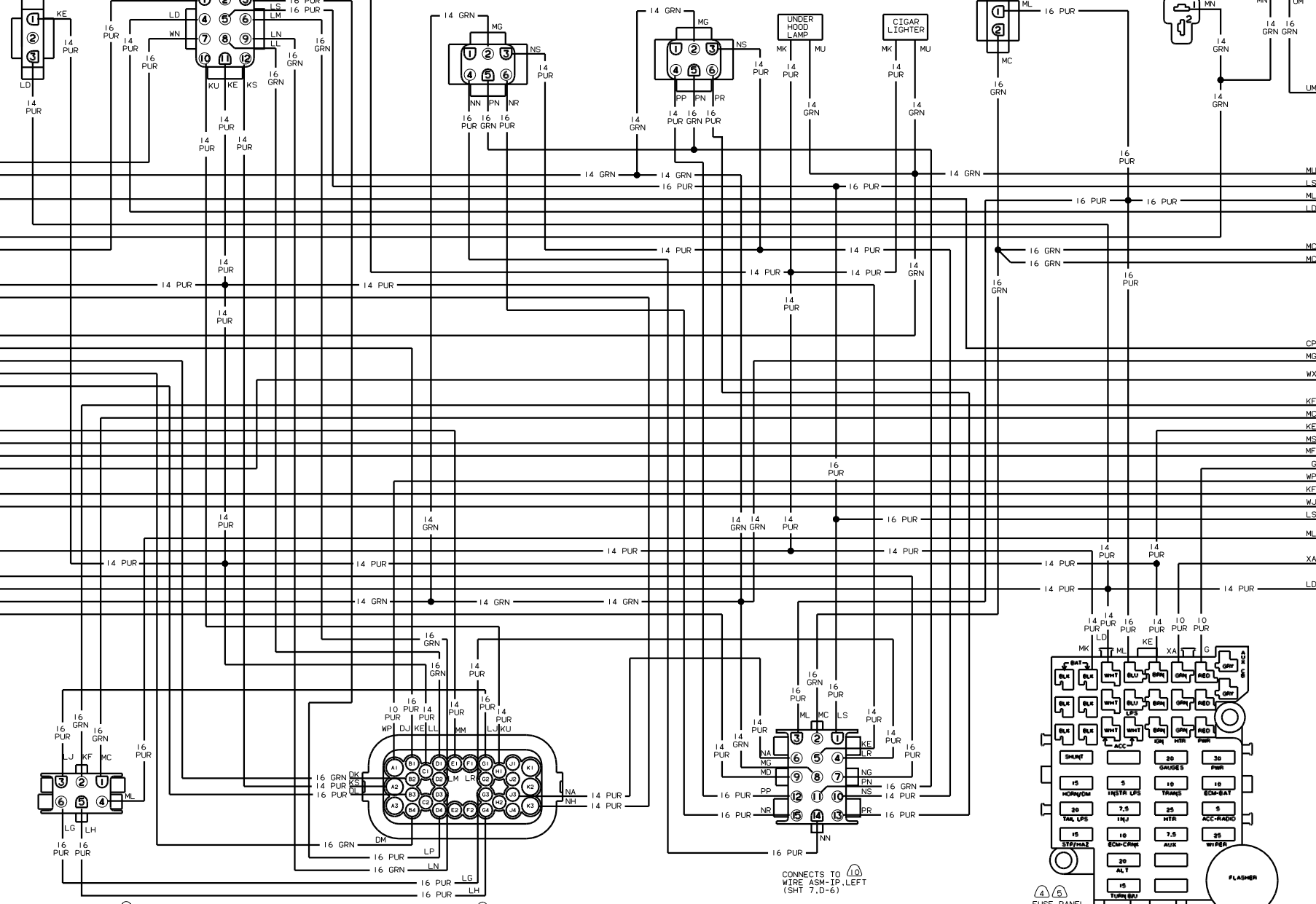

CONNECTS TO WIRE ASM-IP, RIGHT (SHT 7, D-3)

CONNECTS TO WIRE ASM-CHASSIS

CONNECTS TO WIRE ASM-IP, LEFT (SHT 7, D-6)

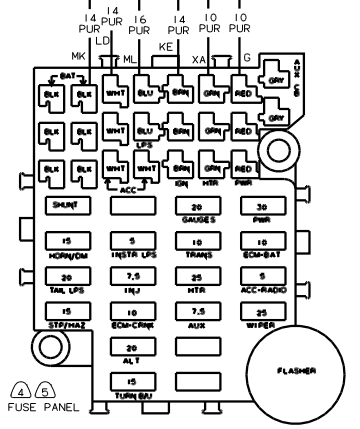

131806 S2F2

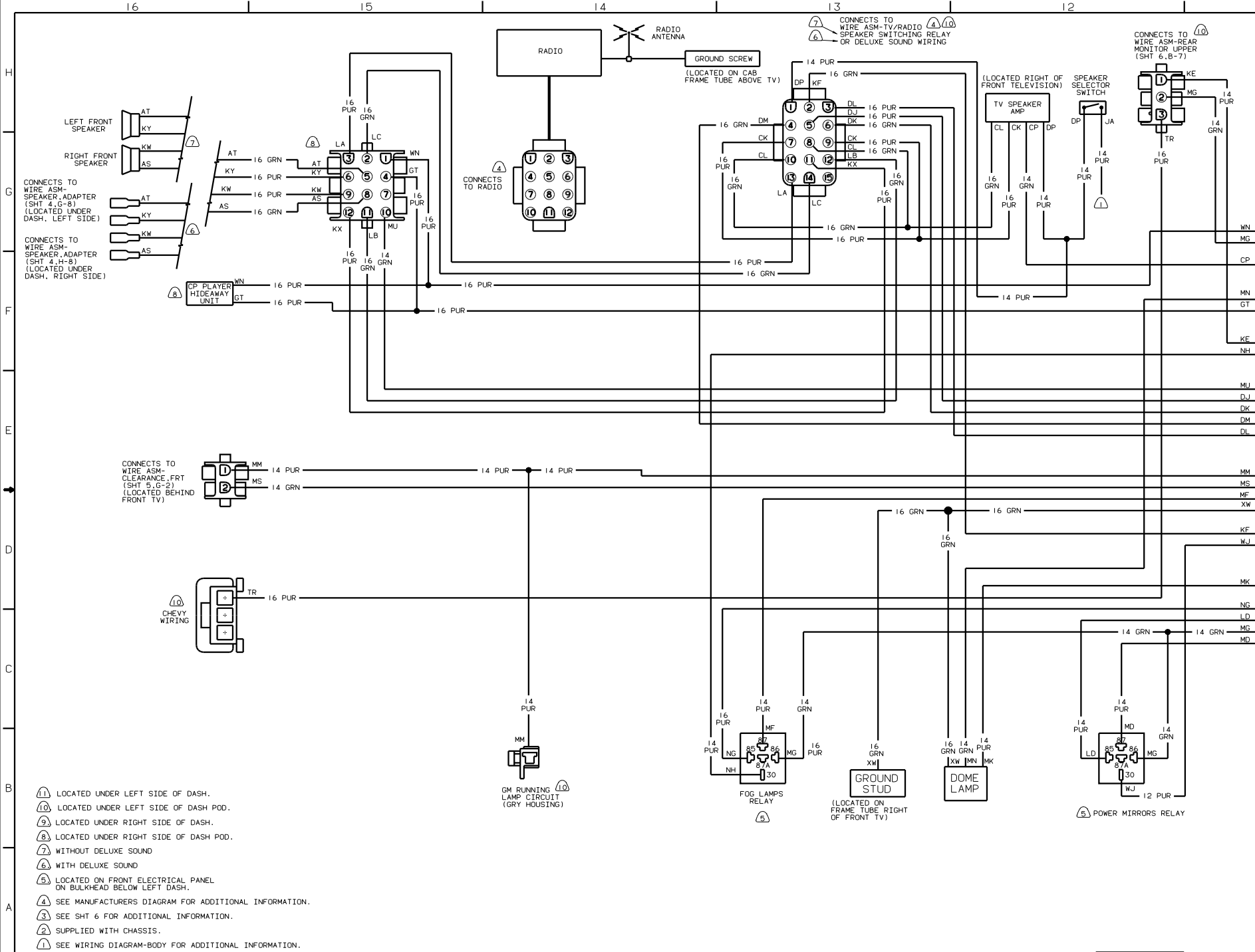

- (11) LOCATED UNDER LEFT SIDE OF DASH.
 (10) LOCATED UNDER LEFT SIDE OF DASH POD.
 (9) LOCATED UNDER RIGHT SIDE OF DASH.
 (8) LOCATED UNDER RIGHT SIDE OF DASH POD.
 (7) WITHOUT DELUXE SOUND
 (6) WITH DELUXE SOUND
 (5) LOCATED ON FRONT ELECTRICAL PANEL ON BULKHEAD BELOW LEFT DASH.
 (4) SEE MANUFACTURERS DIAGRAM FOR ADDITIONAL INFORMATION.
 (3) SEE SHT 6 FOR ADDITIONAL INFORMATION.
 (2) SUPPLIED WITH CHASSIS.
 (1) SEE WIRING DIAGRAM-BODY FOR ADDITIONAL INFORMATION.

(LOCATED ON TOP OF STEERING COLUMN SUPPORT)

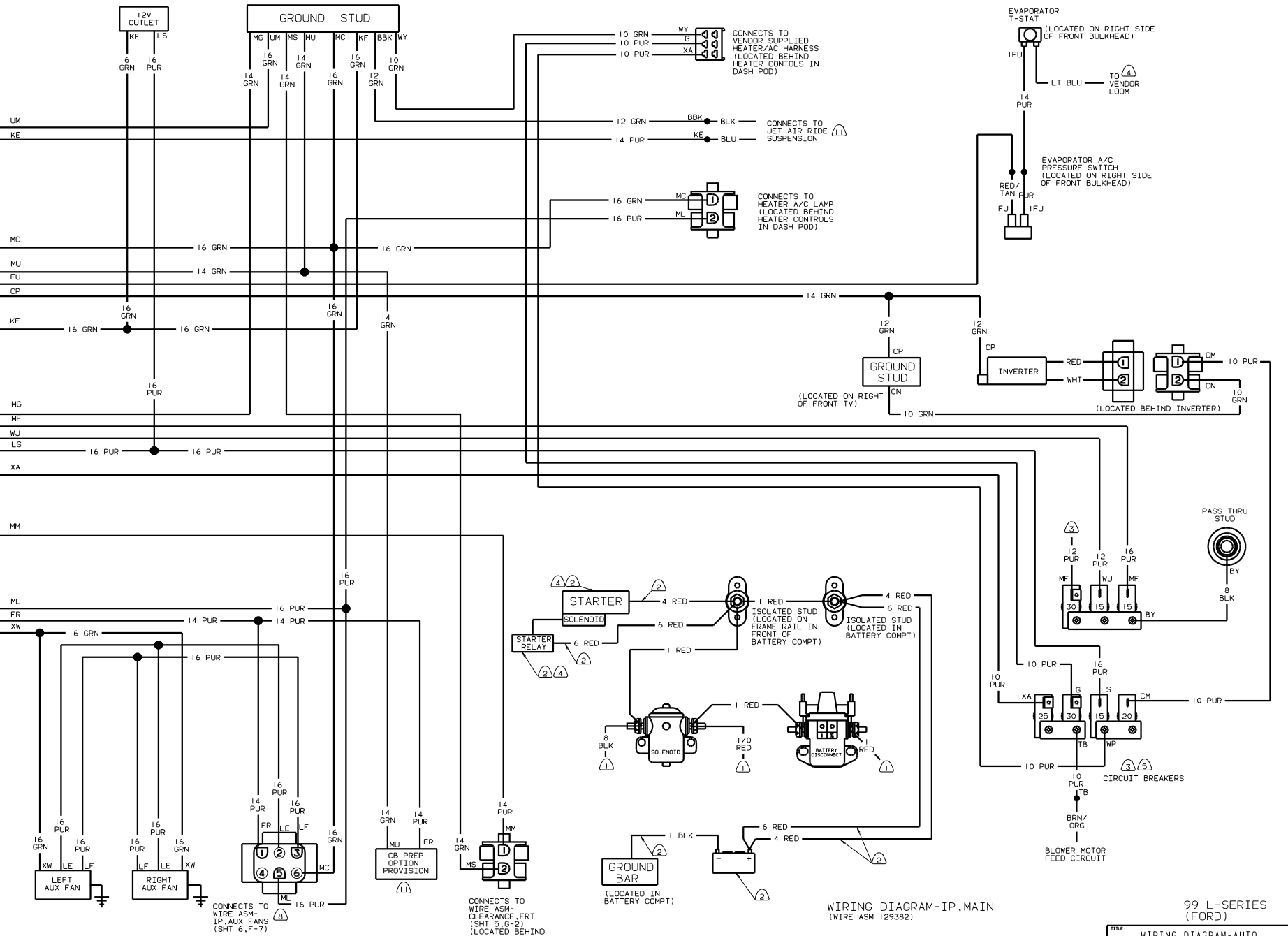

WIRING DIAGRAM-IP, MAIN (WIRE ASM 129382)

99 L-SERIES (FORD)

TITLE		WIRING DIAGRAM-AUTO	
DATE	BY	REV	131806
10/10/05	113	1	
PAGE		3 OF 8	

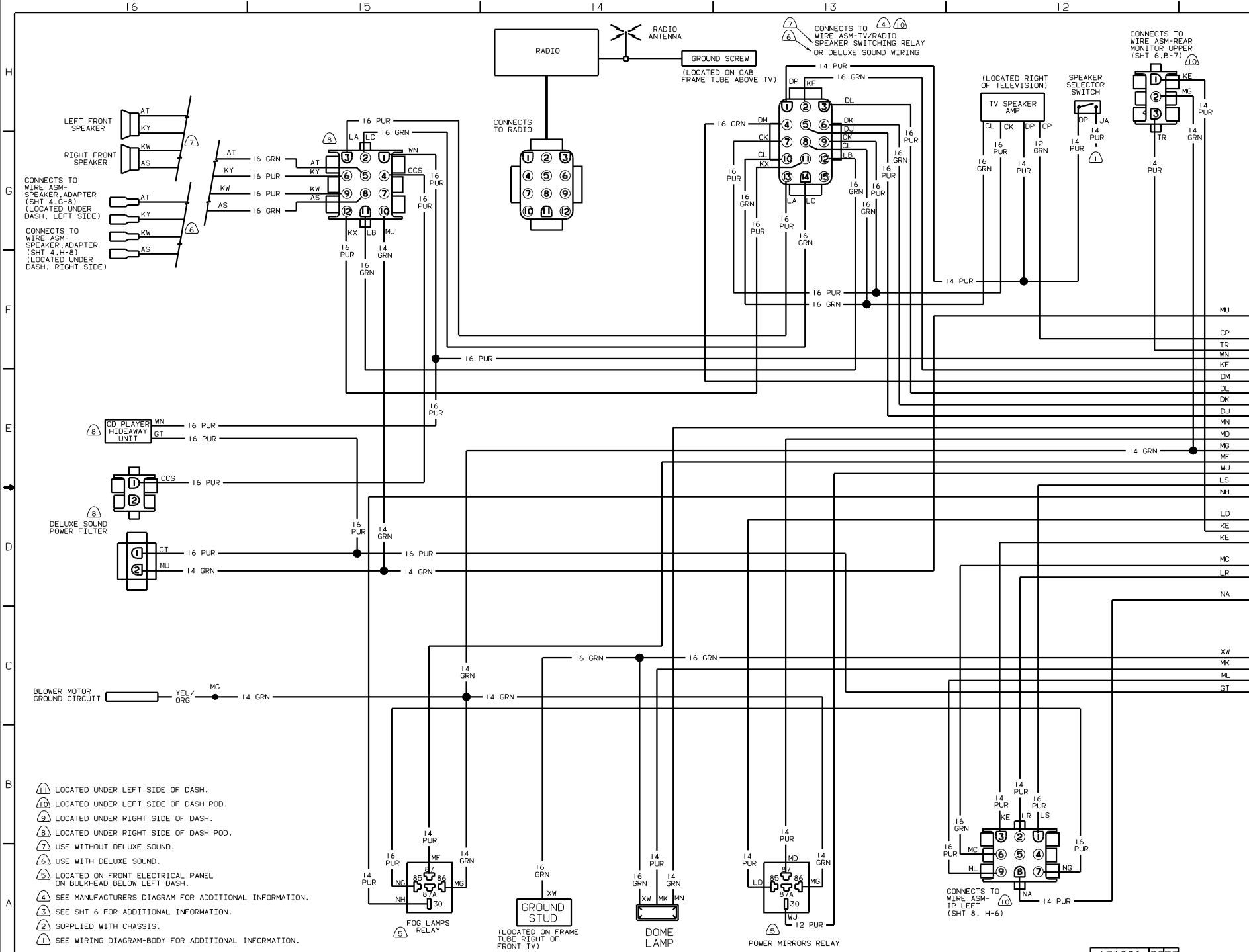

CONNECTS TO LEFT FRONT SPEAKER
 CONNECTS TO RIGHT FRONT SPEAKER

CONNECTS TO WIRE ASM-SPEAKER ADAPTER (SHT 4,G-8) (LOCATED UNDER DASH, LEFT SIDE)

CONNECTS TO WIRE ASM-SPEAKER ADAPTER (SHT 4,H-8) (LOCATED UNDER DASH, RIGHT SIDE)

CD PLAYER HIDEAWAY UNIT

DELUXE SOUND POWER FILTER

BLOWER MOTOR GROUND CIRCUIT

- NOTES:
- (11) LOCATED UNDER LEFT SIDE OF DASH.
 - (10) LOCATED UNDER LEFT SIDE OF DASH POD.
 - (9) LOCATED UNDER RIGHT SIDE OF DASH.
 - (8) LOCATED UNDER RIGHT SIDE OF DASH POD.
 - (7) USE WITHOUT DELUXE SOUND.
 - (6) USE WITH DELUXE SOUND.
 - (5) LOCATED ON FRONT ELECTRICAL PANEL ON BULKHEAD BELOW LEFT DASH.
 - (4) SEE MANUFACTURERS DIAGRAM FOR ADDITIONAL INFORMATION.
 - (3) SEE SHT 6 FOR ADDITIONAL INFORMATION.
 - (2) SUPPLIED WITH CHASSIS.
 - (1) SEE WIRING DIAGRAM-BODY FOR ADDITIONAL INFORMATION.

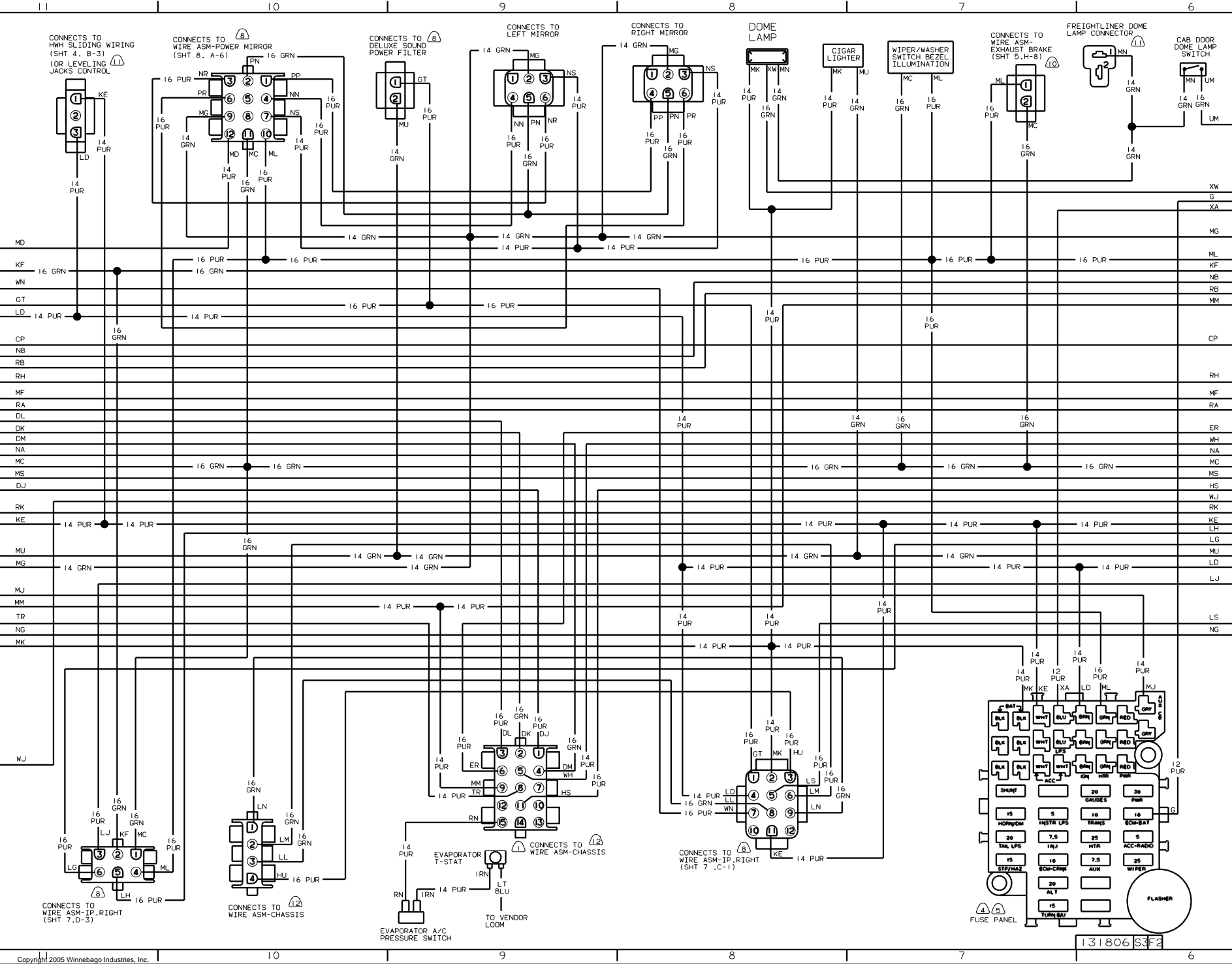

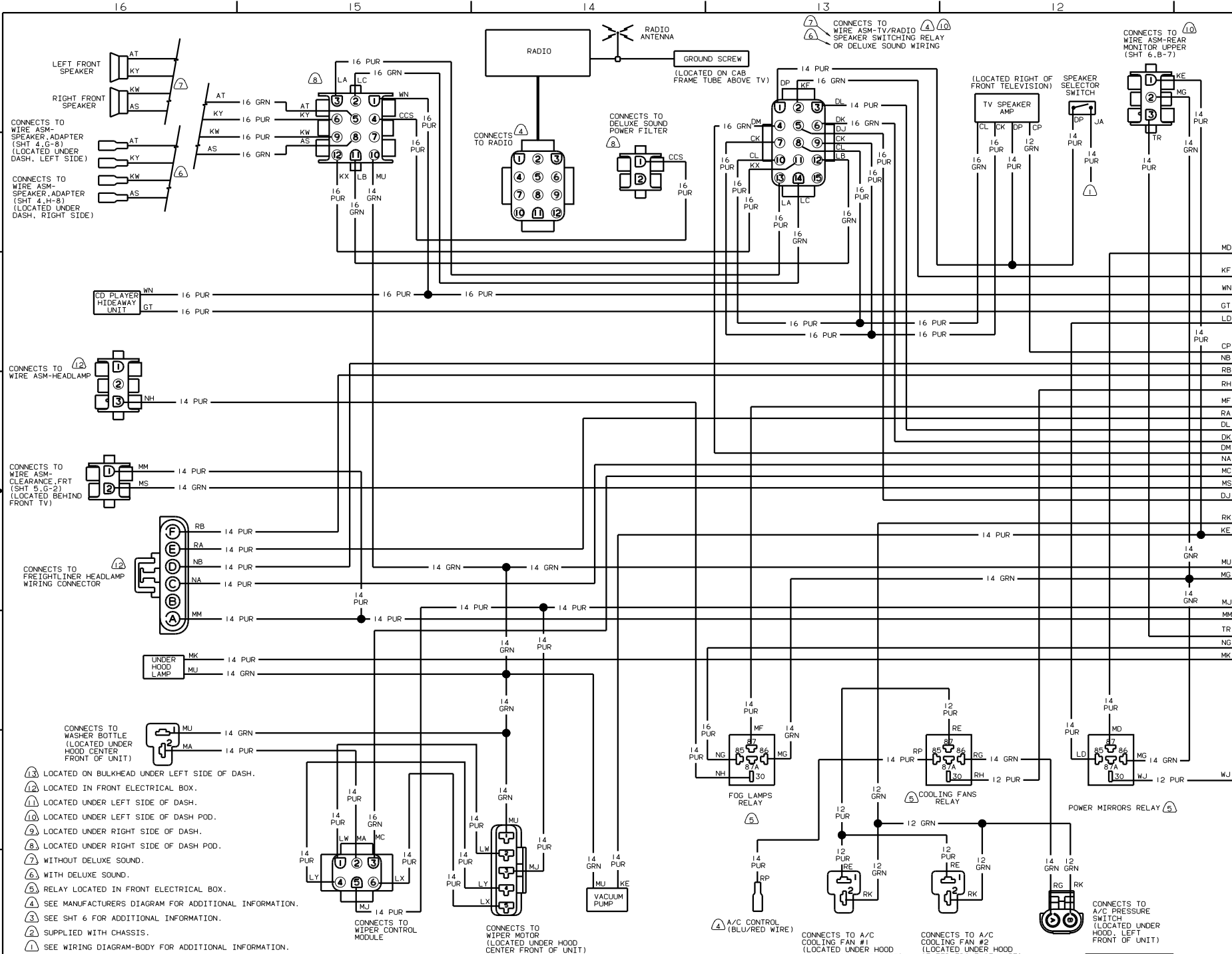

- NOTES:
- ⑬ LOCATED ON BULKHEAD UNDER LEFT SIDE OF DASH.
 - ⑫ LOCATED IN FRONT ELECTRICAL BOX.
 - ⑪ LOCATED UNDER LEFT SIDE OF DASH.
 - ⑩ LOCATED UNDER LEFT SIDE OF DASH POD.
 - ⑨ LOCATED UNDER RIGHT SIDE OF DASH.
 - ⑧ LOCATED UNDER RIGHT SIDE OF DASH POD.
 - ⑦ WITHOUT DELUXE SOUND.
 - ⑥ WITH DELUXE SOUND.
 - ⑤ RELAY LOCATED IN FRONT ELECTRICAL BOX.
 - ④ SEE MANUFACTURERS DIAGRAM FOR ADDITIONAL INFORMATION.
 - ③ SEE SHT 6 FOR ADDITIONAL INFORMATION.
 - ② SUPPLIED WITH CHASSIS.
 - ① SEE WIRING DIAGRAM-BODY FOR ADDITIONAL INFORMATION.

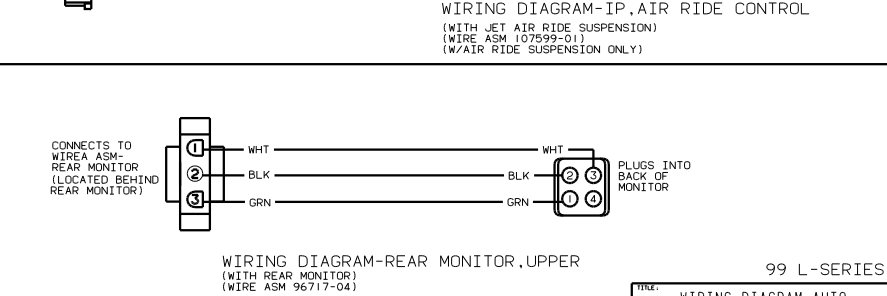
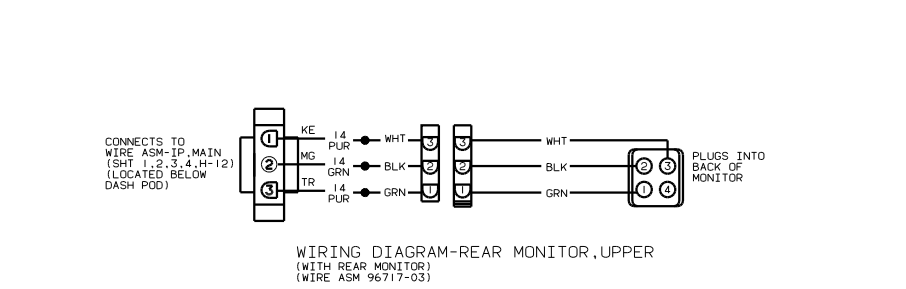
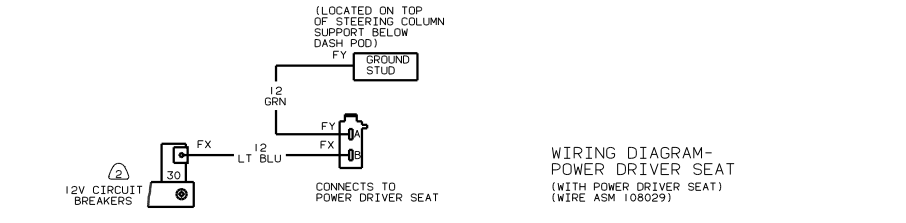
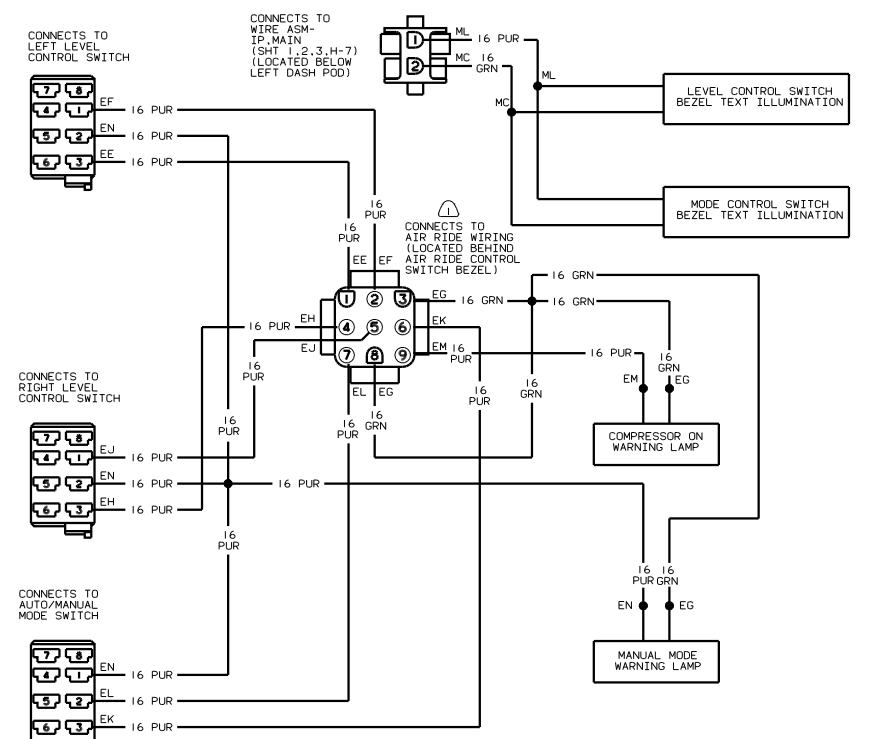
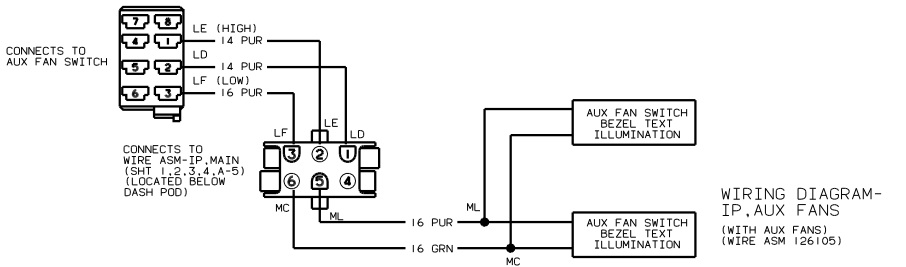
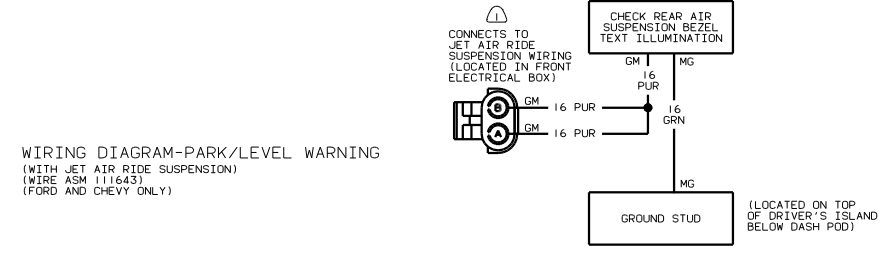
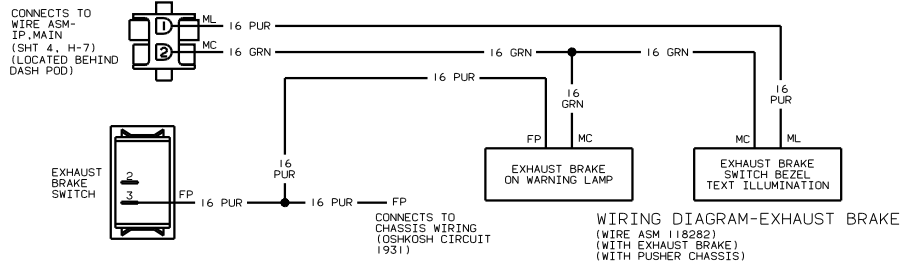

SEE SHT'S 1, 2, 3, & 4 FOR ADDITIONAL INFORMATION.
SEE MANUFACTURER'S DIAGRAM FOR ADDITIONAL INFORMATION.

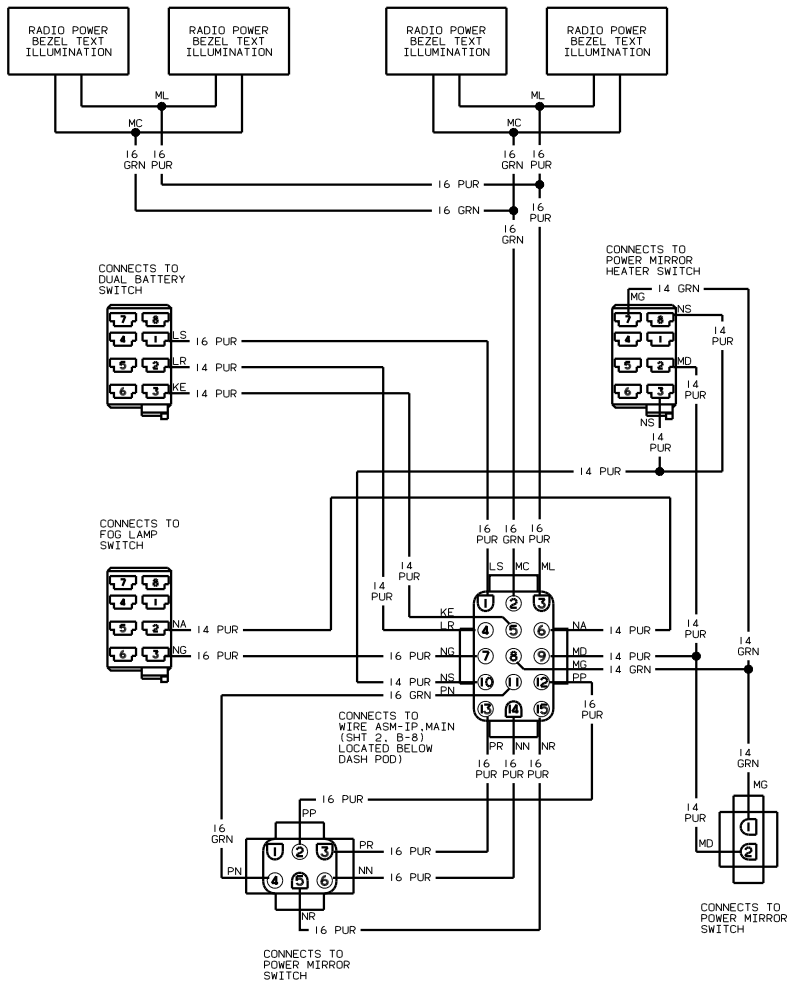

WIRING DIAGRAM-IP, LEFT
(WIRE ASM 125577)

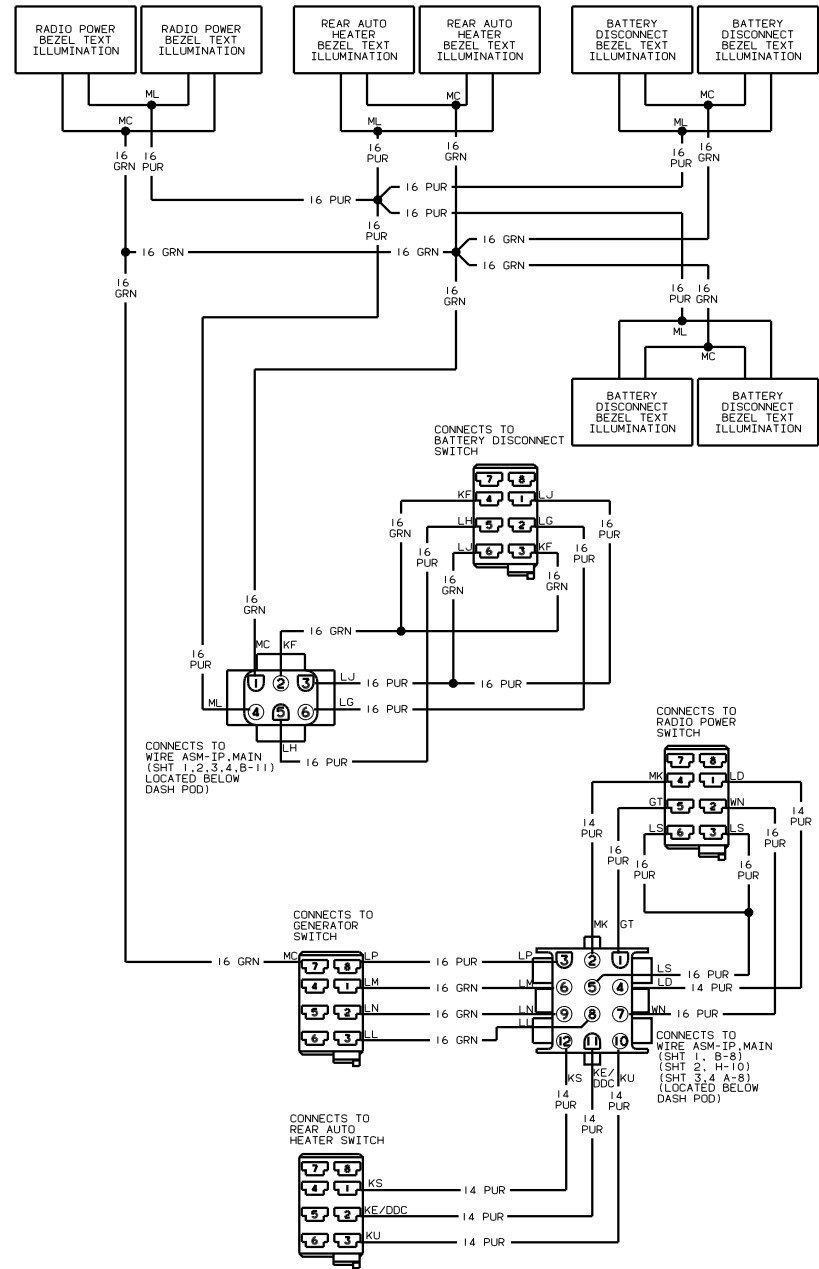

WIRING DIAGRAM-IP, RIGHT
(WIRE ASM 125578)

99 L-SERIES

TITLE		WIRING DIAGRAM-AUTO	
30	NO SCALE	REV	1 E
SHEET	7	OF	8
131806			

