



DANGER

Danger of electrical shock, burns or death. Always remove all power sources before attempting any repair, service or diagnostic work. Power can be present from shore power, generator, inverter or battery. All power sources must be disabled and secured before performing any service.



CAUTION

If you lack the skills, tools or equipment to perform diagnostic or repair work leave such work to an authorized Winnebago Industries dealer or other qualified shop.

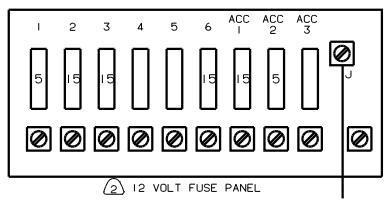

GROUND STUD (LOCATED ON LEFT CHASSIS RAIL AHEAD OF REAR WHEELS)

GROUND STUD (LOCATED ON LEFT CHASSIS RAIL AHEAD OF REAR WHEELS)

⚠ WIRE ASM-IP MAIN (LOCATED IN FRONT ELECTRICAL BOX)

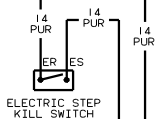
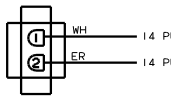

CONNECTS TO ELECTRIC STEP

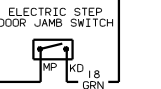
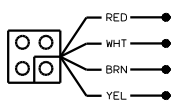

(LOCATED BEHIND BATTERY BOX)

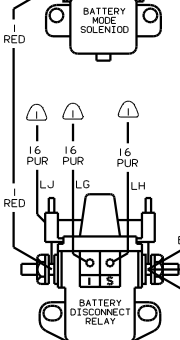
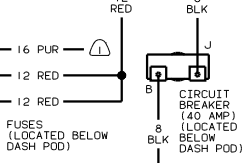
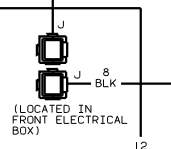
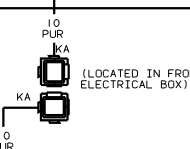
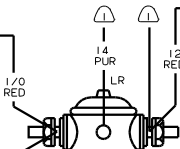
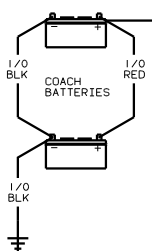
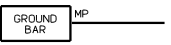

GENERATOR

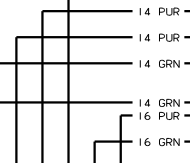
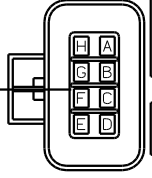

WIRE ASM-COACH (SHT 2-B-14) (LOCATED IN BOTTOM OF GALLEY CABT)

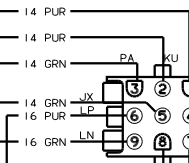

WIRE ASM-COACH (SHT 2-B-13) (LOCATED IN BOTTOM OF GALLEY CABT)

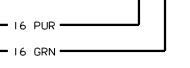

⚠ WIRE ASM-IP MAIN (LOCATED IN FRONT ELECTRICAL BOX)



WIRING DIAGRAM-CHASSIS (WIRE ASM 122539)

⚠ SEE SHT 2 FOR ADDITIONAL INFORMATION.
 ⚠ SEE WIRING DIAGRAM-AUTO FOR ADDITIONAL WIRING.

WINNEBAGO 99 F30N	
DATE	UNSPECIFIED TOLERANCES ARE:
DATE	FRAGILE
DATE	ONE-PLACE (19.21)
DATE	TWO-PLACE (19.20)
DATE	THREE-PLACE (19.20)
DATE	FOUR-PLACE (19.20)
DATE	FIVE-PLACE (19.20)
DATE	SIX-PLACE (19.20)
DATE	SEVEN-PLACE (19.20)
DATE	EIGHT-PLACE (19.20)
DATE	NINE-PLACE (19.20)
DATE	TEN-PLACE (19.20)
DATE	ELEVEN-PLACE (19.20)
DATE	TWELVE-PLACE (19.20)
DATE	THIRTY-PLACE (19.20)
DATE	THIRTY-ONE-PLACE (19.20)
DATE	THIRTY-TWO-PLACE (19.20)
DATE	THIRTY-THREE-PLACE (19.20)
DATE	THIRTY-FOUR-PLACE (19.20)
DATE	THIRTY-FIVE-PLACE (19.20)
DATE	THIRTY-SIX-PLACE (19.20)
DATE	THIRTY-SEVEN-PLACE (19.20)
DATE	THIRTY-EIGHT-PLACE (19.20)
DATE	THIRTY-NINE-PLACE (19.20)
DATE	FOURTY-PLACE (19.20)
DATE	FOURTY-ONE-PLACE (19.20)
DATE	FOURTY-TWO-PLACE (19.20)
DATE	FOURTY-THREE-PLACE (19.20)
DATE	FOURTY-FOUR-PLACE (19.20)
DATE	FOURTY-FIVE-PLACE (19.20)
DATE	FOURTY-SIX-PLACE (19.20)
DATE	FOURTY-SEVEN-PLACE (19.20)
DATE	FOURTY-EIGHT-PLACE (19.20)
DATE	FOURTY-NINE-PLACE (19.20)
DATE	FIFTY-PLACE (19.20)
DATE	FIFTY-ONE-PLACE (19.20)
DATE	FIFTY-TWO-PLACE (19.20)
DATE	FIFTY-THREE-PLACE (19.20)
DATE	FIFTY-FOUR-PLACE (19.20)
DATE	FIFTY-FIVE-PLACE (19.20)
DATE	FIFTY-SIX-PLACE (19.20)
DATE	FIFTY-SEVEN-PLACE (19.20)
DATE	FIFTY-EIGHT-PLACE (19.20)
DATE	FIFTY-NINE-PLACE (19.20)
DATE	SIXTY-PLACE (19.20)
DATE	SIXTY-ONE-PLACE (19.20)
DATE	SIXTY-TWO-PLACE (19.20)
DATE	SIXTY-THREE-PLACE (19.20)
DATE	SIXTY-FOUR-PLACE (19.20)
DATE	SIXTY-FIVE-PLACE (19.20)
DATE	SIXTY-SIX-PLACE (19.20)
DATE	SIXTY-SEVEN-PLACE (19.20)
DATE	SIXTY-EIGHT-PLACE (19.20)
DATE	SIXTY-NINE-PLACE (19.20)
DATE	SEVENTY-PLACE (19.20)
DATE	SEVENTY-ONE-PLACE (19.20)
DATE	SEVENTY-TWO-PLACE (19.20)
DATE	SEVENTY-THREE-PLACE (19.20)
DATE	SEVENTY-FOUR-PLACE (19.20)
DATE	SEVENTY-FIVE-PLACE (19.20)
DATE	SEVENTY-SIX-PLACE (19.20)
DATE	SEVENTY-SEVEN-PLACE (19.20)
DATE	SEVENTY-EIGHT-PLACE (19.20)
DATE	SEVENTY-NINE-PLACE (19.20)
DATE	EIGHTY-PLACE (19.20)
DATE	EIGHTY-ONE-PLACE (19.20)
DATE	EIGHTY-TWO-PLACE (19.20)
DATE	EIGHTY-THREE-PLACE (19.20)
DATE	EIGHTY-FOUR-PLACE (19.20)
DATE	EIGHTY-FIVE-PLACE (19.20)
DATE	EIGHTY-SIX-PLACE (19.20)
DATE	EIGHTY-SEVEN-PLACE (19.20)
DATE	EIGHTY-EIGHT-PLACE (19.20)
DATE	EIGHTY-NINE-PLACE (19.20)
DATE	NINETY-PLACE (19.20)
DATE	NINETY-ONE-PLACE (19.20)
DATE	NINETY-TWO-PLACE (19.20)
DATE	NINETY-THREE-PLACE (19.20)
DATE	NINETY-FOUR-PLACE (19.20)
DATE	NINETY-FIVE-PLACE (19.20)
DATE	NINETY-SIX-PLACE (19.20)
DATE	NINETY-SEVEN-PLACE (19.20)
DATE	NINETY-EIGHT-PLACE (19.20)
DATE	NINETY-NINE-PLACE (19.20)
DATE	HUNDRED-PLACE (19.20)

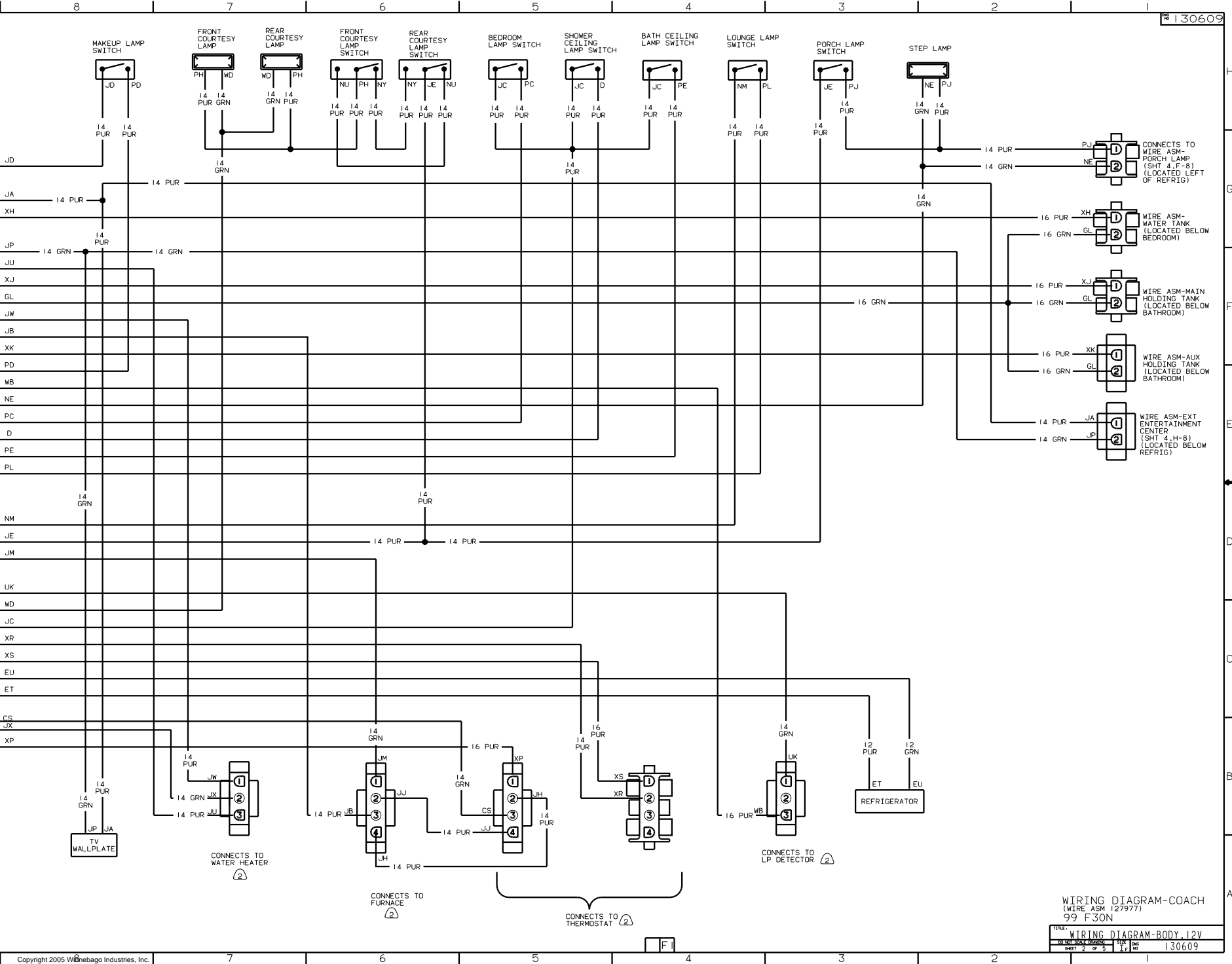

P.J. ①
NE ②
CONNECTS TO WIRE ASM-PORCH LAMP (SHT 4,F-8) (LOCATED LEFT OF REFRIG)

XH ①
GL ②
16 PUR
16 GRN
WIRE ASM-WATER TANK (LOCATED BELOW BEDROOM)

XJ ①
GL ②
16 PUR
16 GRN
WIRE ASM-MAIN HOLDING TANK (LOCATED BELOW BATHROOM)

XK ①
GL ②
16 PUR
16 GRN
WIRE ASM-AUX HOLDING TANK (LOCATED BELOW BATHROOM)

JA ①
JP ②
14 PUR
14 GRN
WIRE ASM-EXT ENTERTAINMENT CENTER (SHT 4,H-8) (LOCATED BELOW REFRIG)

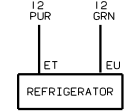

CONNECTS TO LP DETECTOR ②

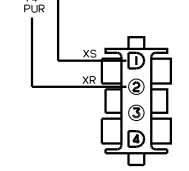

CONNECTS TO THERMOSTAT ②

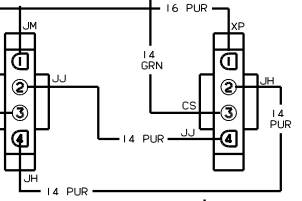

CONNECTS TO FURNACE ②

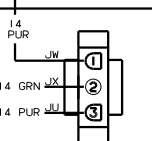

CONNECTS TO WATER HEATER ②



WIRING DIAGRAM-COACH
(WIRE ASM 127977)
99 F30N

TITLE	WIRING DIAGRAM-BODY.12V
NO. OF SHEETS	1
SHEET NO.	2 OF 5
DATE	11/01/09
REV	130609

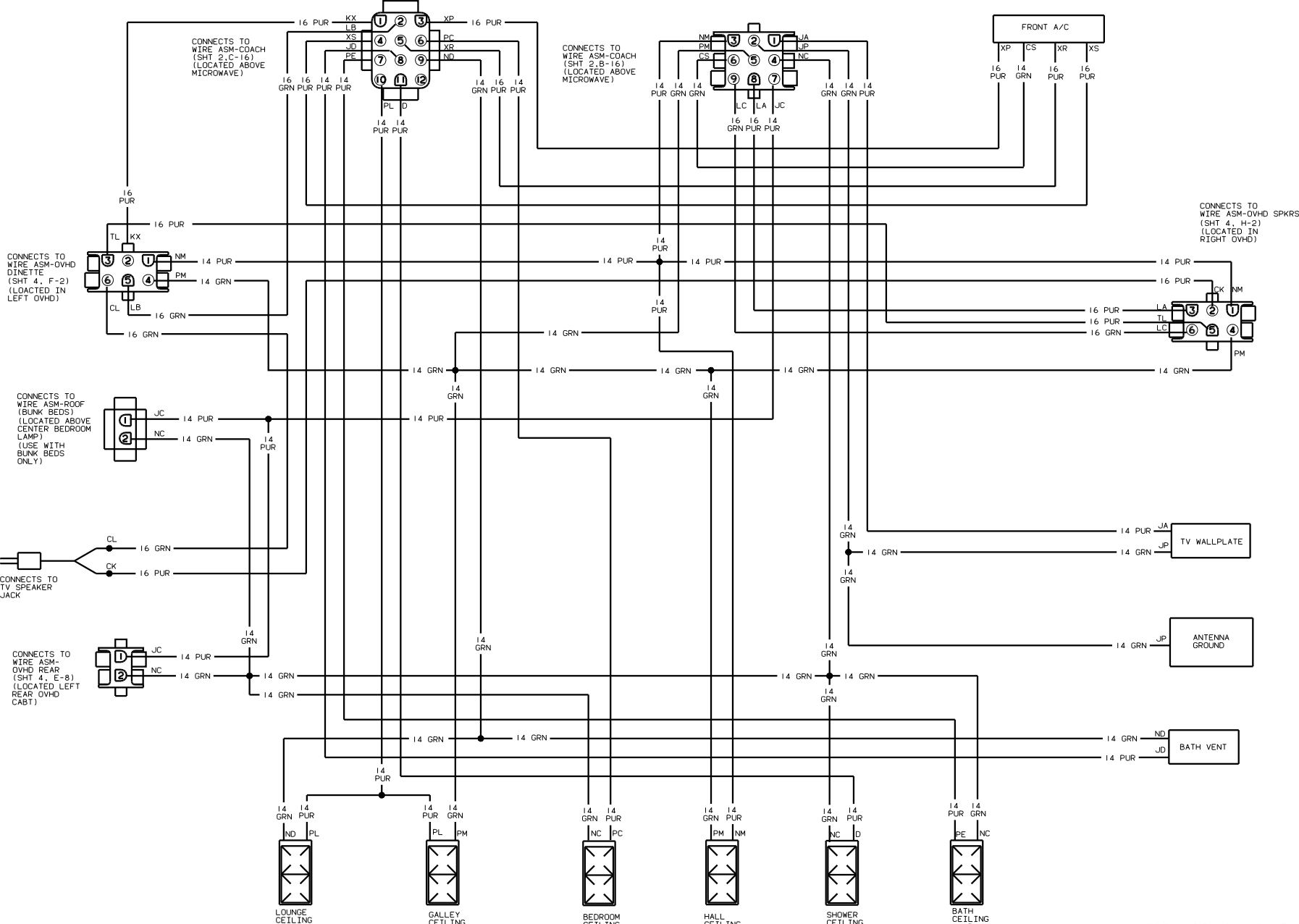

WIRING DIAGRAM-ROOF (WIRE ASM 122358)

99 F30N

TITLE: WIRING DIAGRAM-BODY_12V	
NO. OF SHEETS: 5	SHEET NO: 3
DATE: 1.6	REV: 1.6
130609	

