



DANGER

Danger of electrical shock, burns or death. Always remove all power sources before attempting any repair, service or diagnostic work. Power can be present from shore power, generator, inverter or battery. All power sources must be disabled and secured before performing any service.



CAUTION

If you lack the skills, tools or equipment to perform diagnostic or repair work leave such work to an authorized Winnebago Industries dealer or other qualified shop.

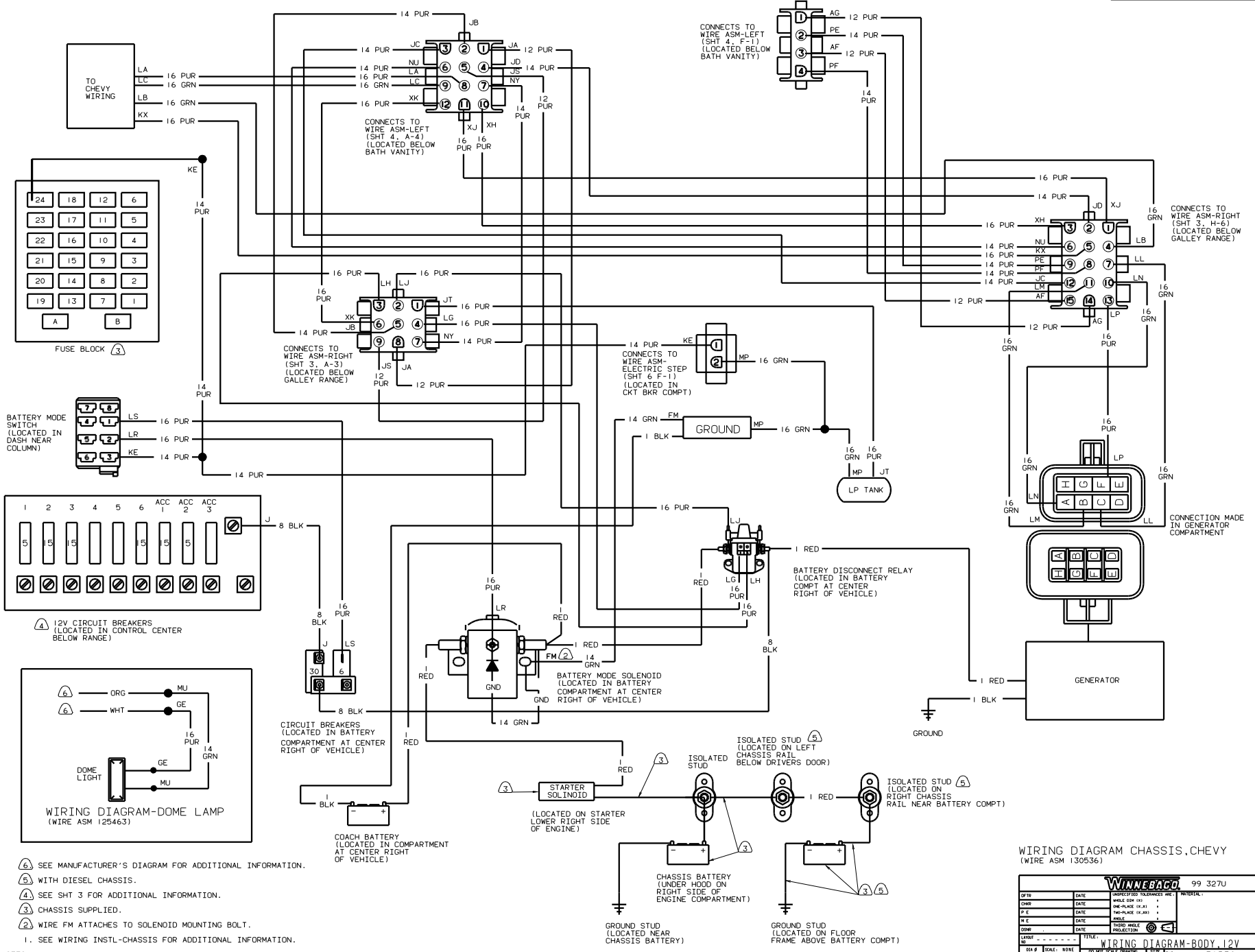

WIRING DIAGRAM CHASSIS, CHEVY (WIRE ASM 130536)

WINNEBAGO 99 327U				
OP/IN	DATE	UNSPECIFIED TOLERANCES ARE:	MATERIAL	
CHP	DATE	WELD (OR 1/4)		
PTF	DATE	ONE-PLATE (1/4, 3/16)		
PL	DATE	ANGLE		
CON	DATE	TRUSS W/ALL PROTECTION		
DRN	DATE	TITLE		
WIRING DIAGRAM-BODY 12V				
SHEET 1	OF 6	TITLE	130532	

NOTES:
 ① SEE MANUFACTURER'S DIAGRAM FOR ADDITIONAL INFORMATION.
 ② WITH DIESEL CHASSIS.
 ③ SEE SHT 3 FOR ADDITIONAL INFORMATION.
 ④ WIRE FM ATTACHES TO SOLENOID MOUNTING BOLT.
 ⑤ SEE WIRING INSTL-CHASSIS FOR ADDITIONAL INFORMATION.

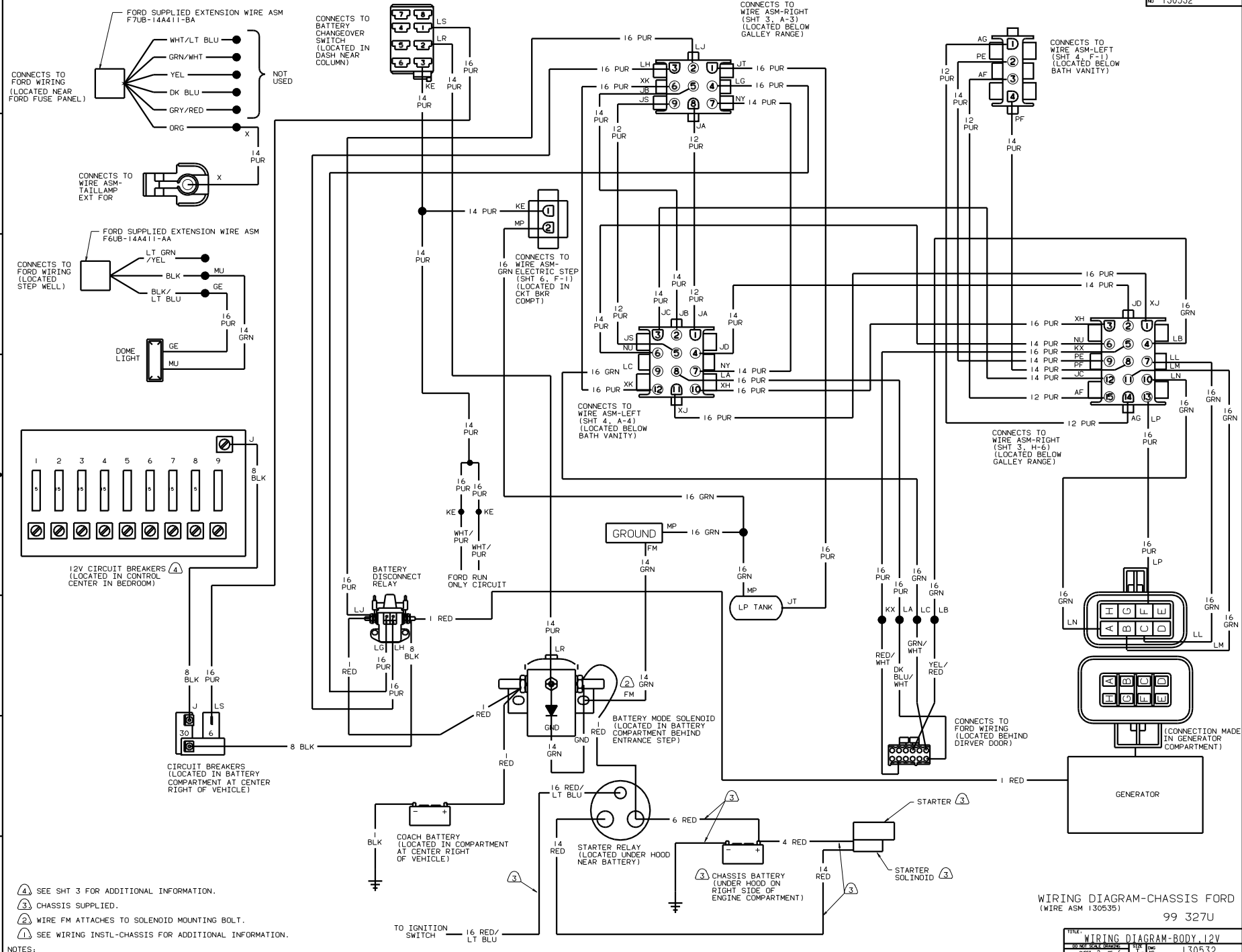

- NOTES:
- ④ SEE SH T 3 FOR ADDITIONAL INFORMATION.
 - ③ CHASSIS SUPPLIED.
 - ② WIRE FM ATTACHES TO SOLENOID MOUNTING BOLT.
 - ① SEE WIRING INSTL-CHASSIS FOR ADDITIONAL INFORMATION.

WIRING DIAGRAM-CHASSIS FORD (WIRE ASM 130535) 99 327U

TITLE: WIRING DIAGRAM-BODY 12V	
NO. OF SHEETS: 6	SHEET: 2 OF 6
DATE: 1/8	REV: 1
130532	

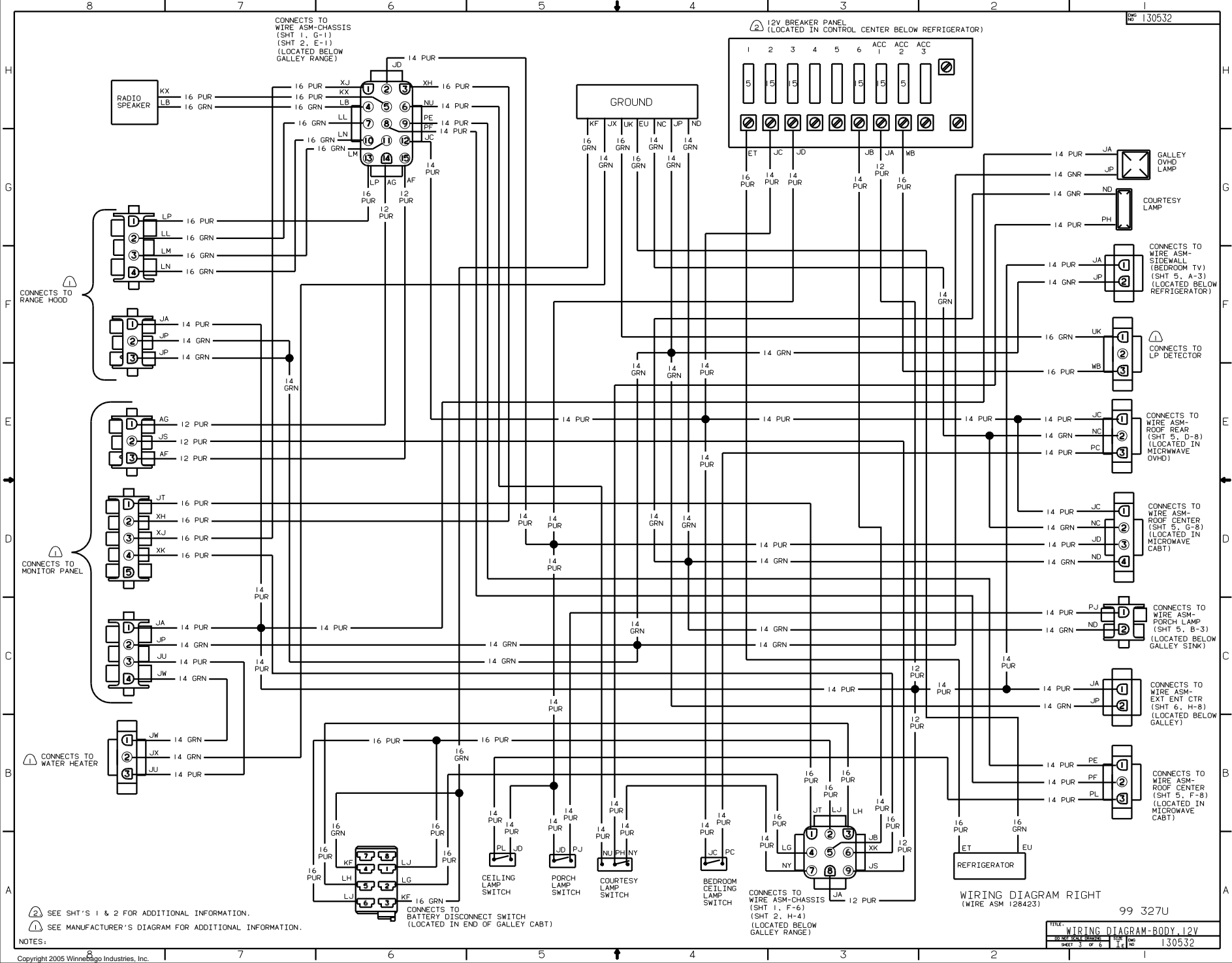

2 SEE SHT'S 1 & 2 FOR ADDITIONAL INFORMATION.
 1 SEE MANUFACTURER'S DIAGRAM FOR ADDITIONAL INFORMATION.

CONNECTS TO WIRE ASM-OVHD (SHT 5, B-8) (SHT 6, D-8) (LOCATED IN LEFT FRONT OVHD)

THREMOSTAT

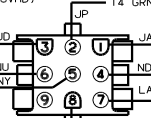

CONNECTS TO FURNACE

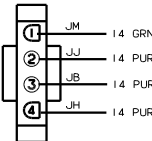

CONNECTS TO WIRE ASM-AUX HOLDING TANK

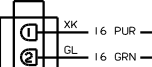

CONNECTS TO WIRE ASM-MAIN HOLDING TANK

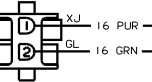

BATH CEILING LAMP SWITCH



SHOWER LAMP SWITCH

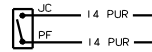

WATER PUMP

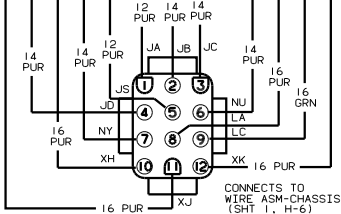
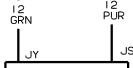

CONNECTS TO WIRE ASM-CHASSIS (SHT 1, H-3) (SHT 2, H-2) (LOCATED BELOW BATH VANITY)

GROUND BAR

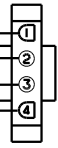

CONNECTS TO WIRE ASM-CHASSIS (SHT 1, H-3) (SHT 2, H-2) (LOCATED BELOW BATH VANITY)

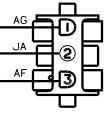

CONNECTS TO WIRE ASM-EXTERIOR WATER PUMP SWITCH

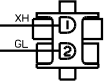

CONNECTS TO WIRE ASM-WATER TANK

WIRING DIAGRAM-LEFT (WIRE ASM 128422)

99 327U

NOTES: (1) SEE MANUFACTURER'S DIAGRAM FOR ADDITIONAL INFORMATION.

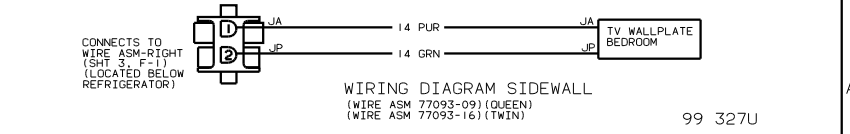
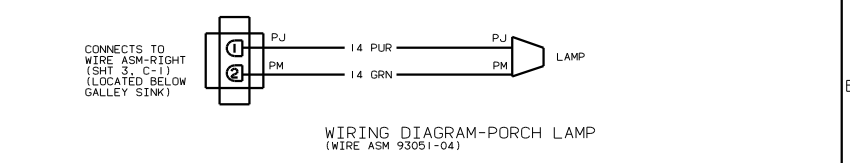
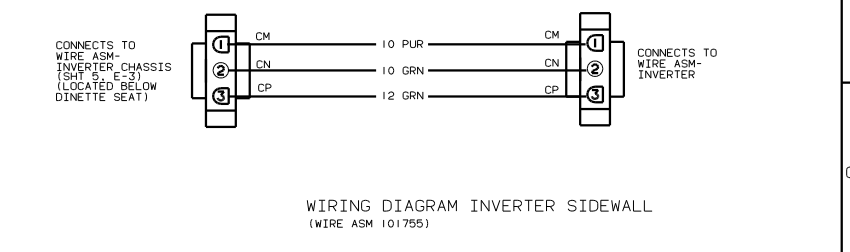
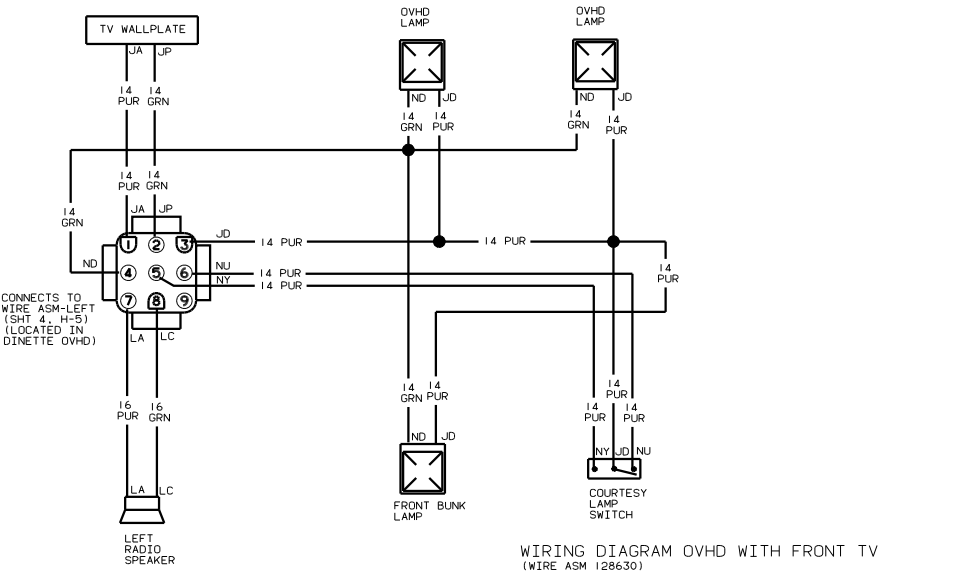
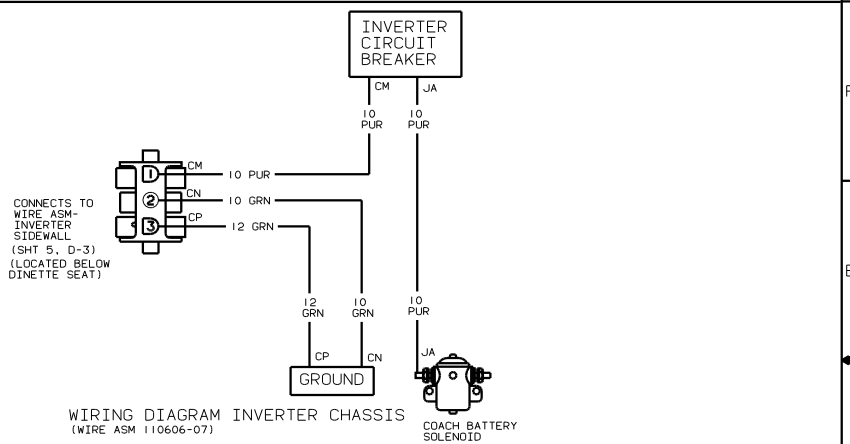
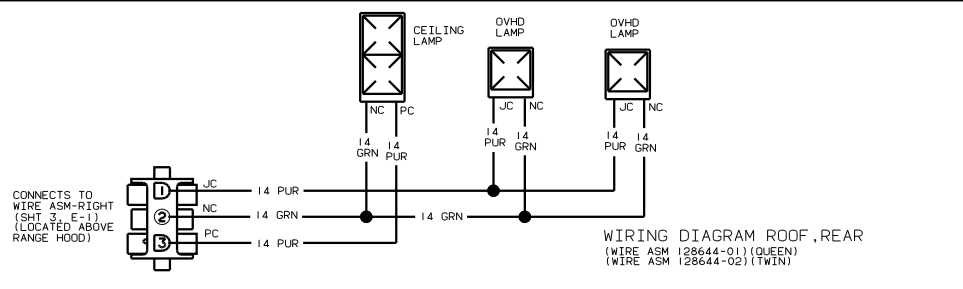
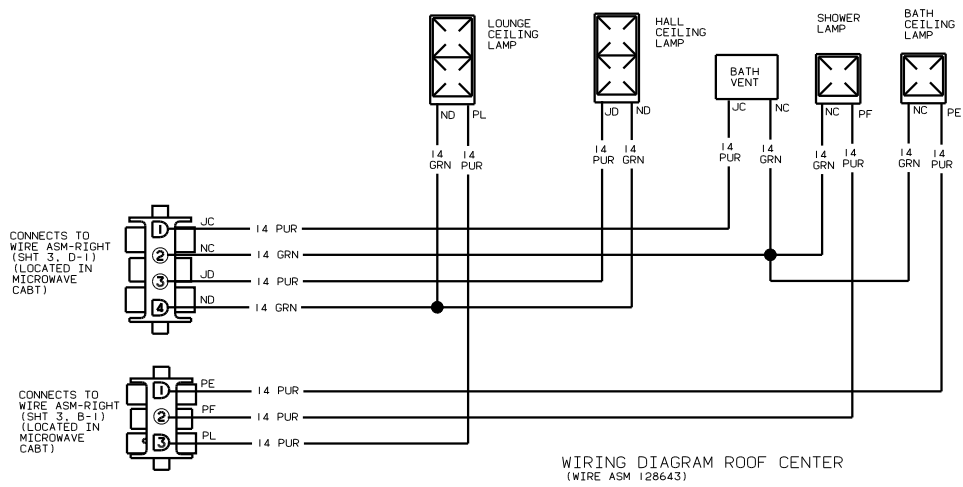

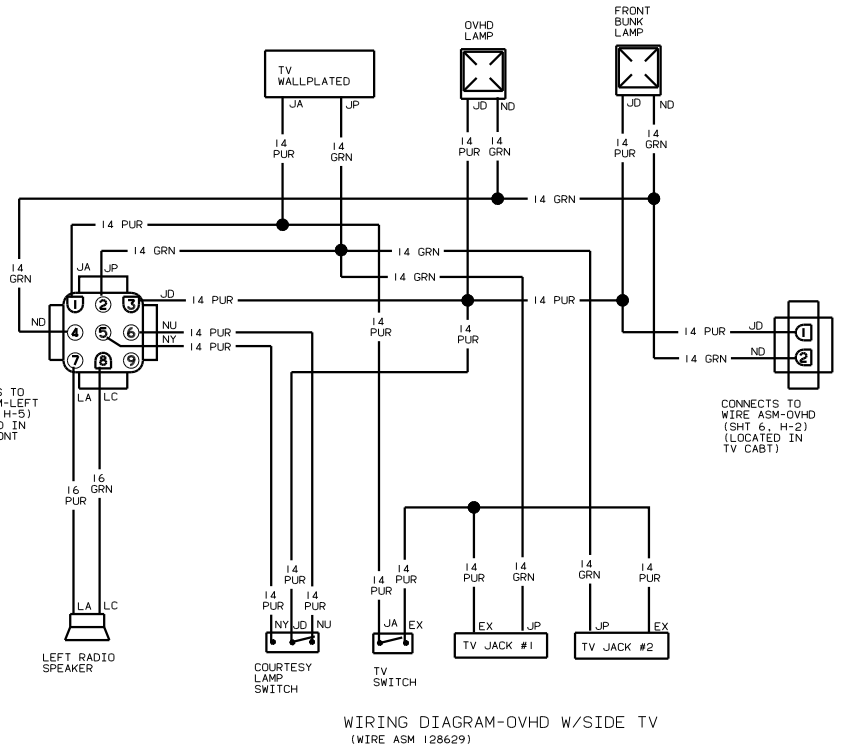
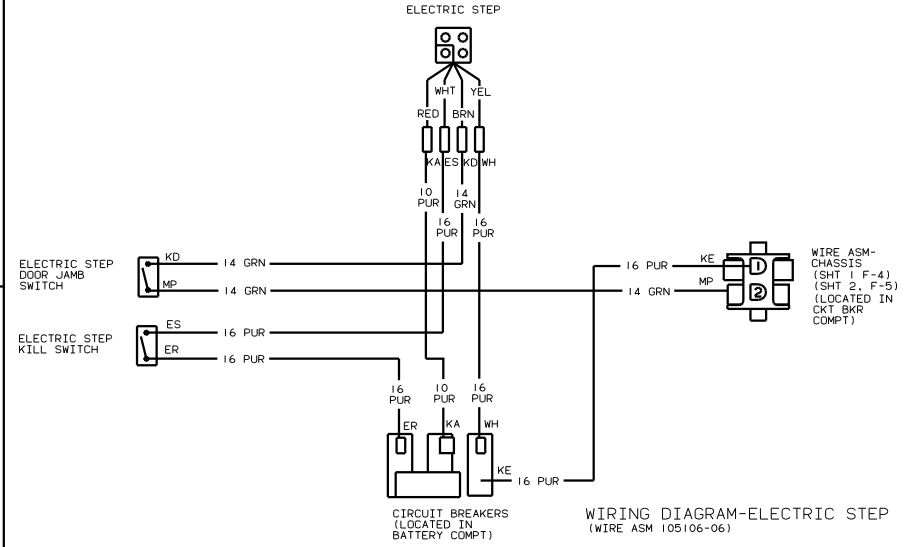
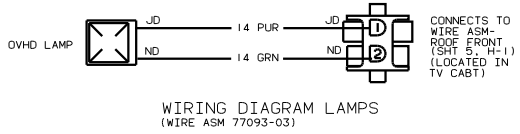
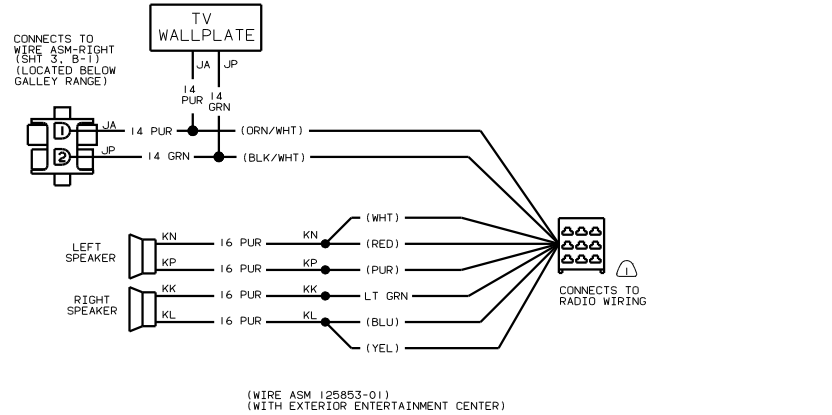

SEE MANUFACTURER'S DIAGRAM FOR ADDITIONAL INFORMATION.