



**DANGER**

**Danger of electrical shock, burns or death.** Always remove all power sources before attempting any repair, service or diagnostic work. Power can be present from shore power, generator, inverter or battery. All power sources must be disabled and secured before performing any service.



**CAUTION**

If you lack the skills, tools or equipment to perform diagnostic or repair work leave such work to an authorized Winnebago Industries dealer or other qualified shop.





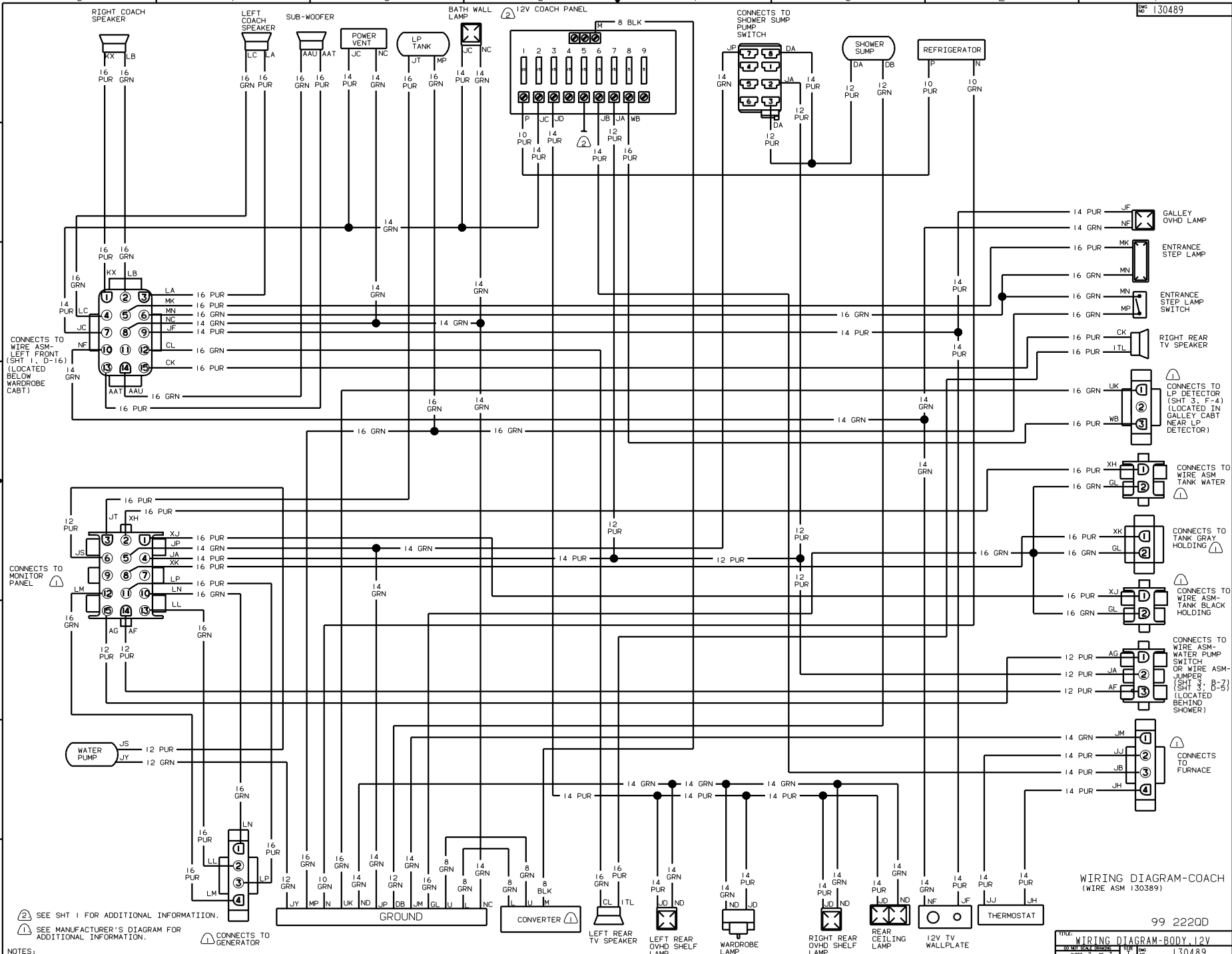

CONNECTS TO WIRE ASM-LEFT FRONT (SHT 1, D-16) (LOCATED BELOW WARDROBE CABT)

CONNECTS TO MONITOR PANEL

NOTES:  
 (2) SEE SHT 1 FOR ADDITIONAL INFORMATION.  
 (1) SEE MANUFACTURER'S DIAGRAM FOR ADDITIONAL INFORMATION.

CONNECTS TO GENERATOR

WIRING DIAGRAM-COACH (WIRE ASM 130389)

99 2220D

TITLE:	WIRING DIAGRAM-BODY 12V
NO. OF SHEETS:	3
SHEET NO.:	2 OF 3
DATE:	1.6
REV. NO.:	130489

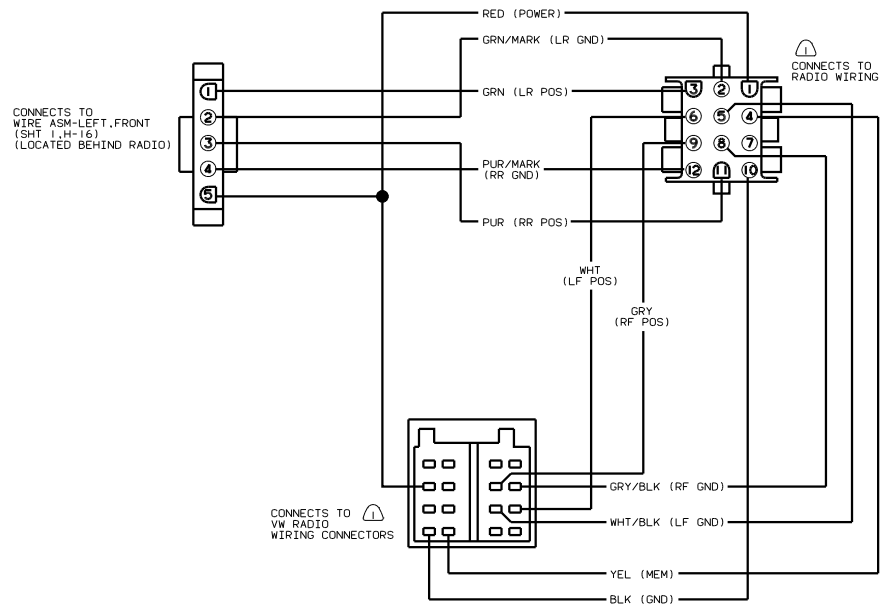

WIRING DIAGRAM-ADAPTER, RADIO (WIRE ASM 114365-02)

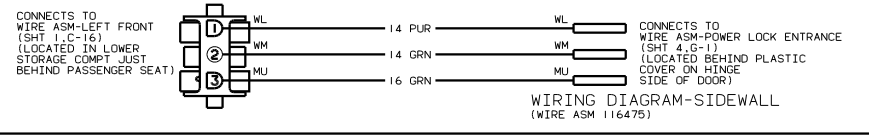

WIRING DIAGRAM-SIDEWALL (WIRE ASM 116475)

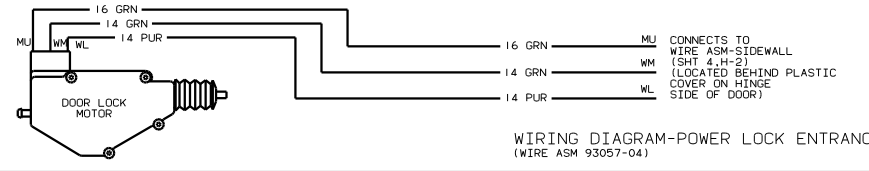

WIRING DIAGRAM-POWER LOCK ENTRANCE (WIRE ASM 93057-04)

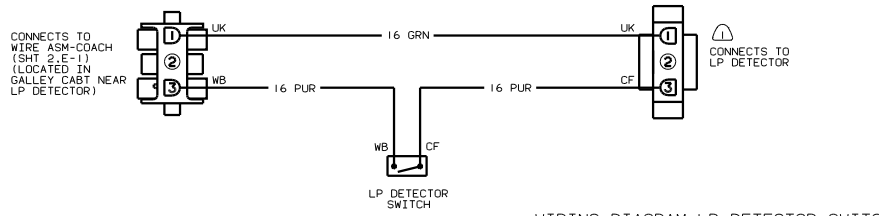

WIRING DIAGRAM-LP DETECTOR SWITCH (JAPANESE UNITS ONLY) (WIRE ASM 115733)

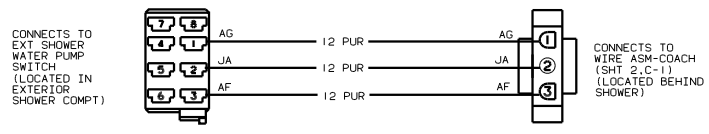

WIRING DIAGRAM WATER PUMP, SWITCH (WIRE ASM 103494-04) (WITH EXTERIOR SHOWER)

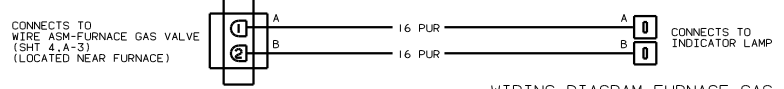

WIRING DIAGRAM-FURNACE GAS LIGHT (JAPANESE UNITS ONLY) (WIRE ASM 107574)

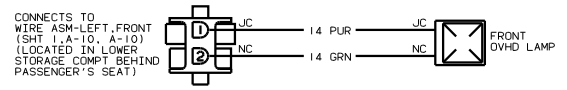

WIRING DIAGRAM-SIDEWALL (WIRE ASM 114745)

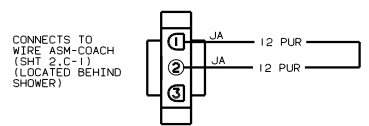

WIRING DIAGRAM-JUMPER (WIRE ASM 103493) (WITHOUT EXTERIOR SHOWER)

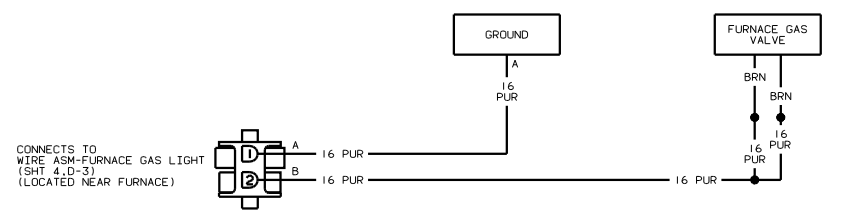

WIRING DIAGRAM-FURNACE GAS VALVE (JAPANESE UNITS ONLY) (WIRE ASM 107573)

1) SEE MANUFACTURER'S DIAGRAM FOR ADDITIONAL INFORMATION.