



DANGER

Danger of electrical shock, burns or death. Always remove all power sources before attempting any repair, service or diagnostic work. Power can be present from shore power, generator, inverter or battery. All power sources must be disabled and secured before performing any service.



CAUTION

If you lack the skills, tools or equipment to perform diagnostic or repair work leave such work to an authorized Winnebago Industries dealer or other qualified shop.

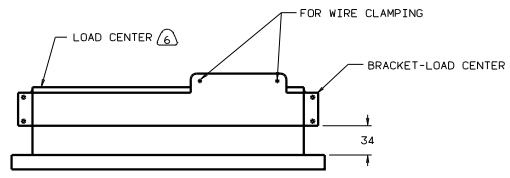

VIEW AA-AA

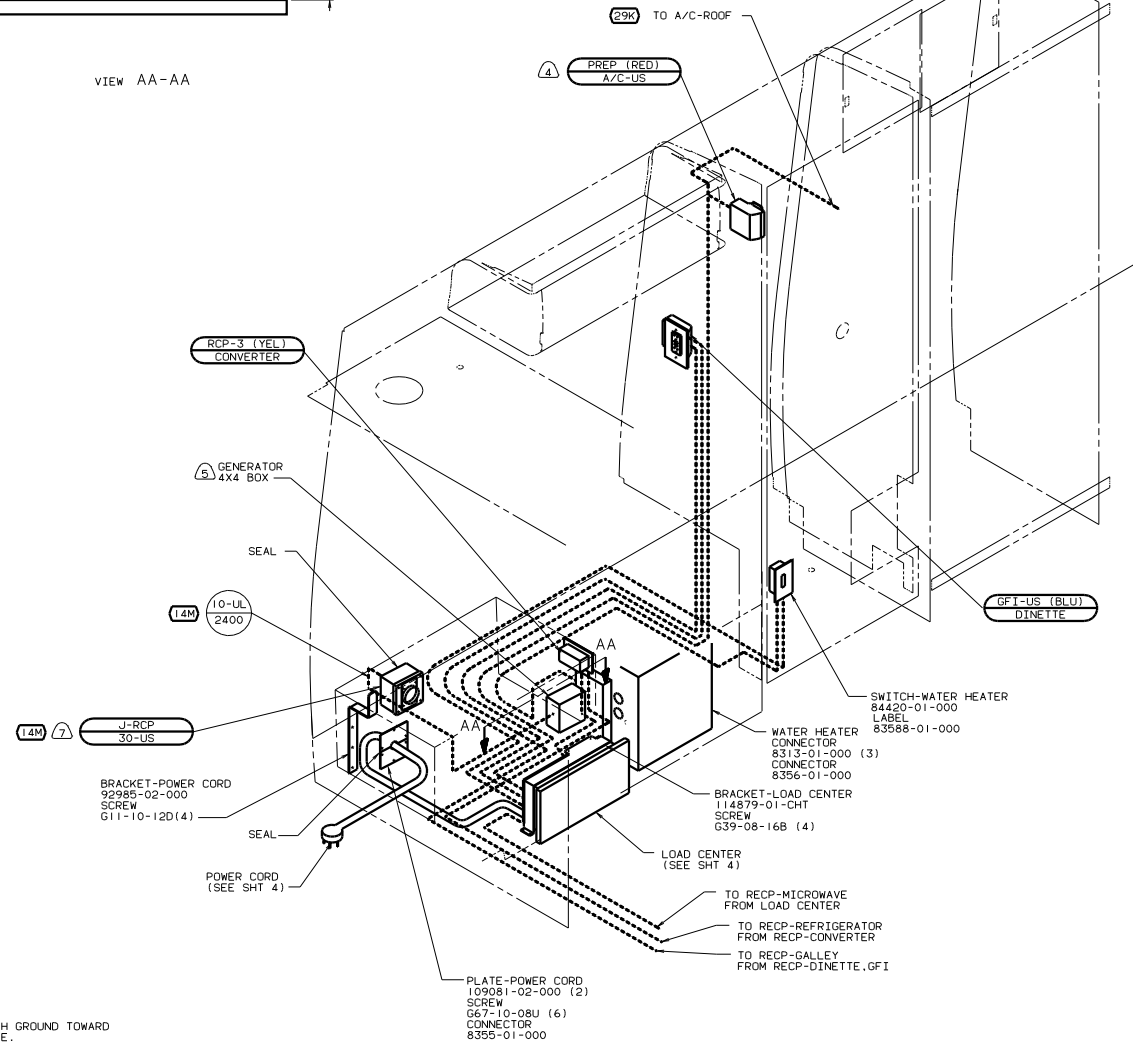

- (7) INSTALL RECP WITH GROUND TOWARD BOTTOM OF VEHICLE.
- (6) LOCATE LOAD CENTER WITHIN DINETTE SEAT FACE.
- (5) SEE GENERATOR INSTL FOR ADDITIONAL INFORMATION.
- (4) NOT USED WITH (29K)
3. ALL GROUND WIRES TO BE COVERED WITH TUBING 8041-02-000.
2. ALL WIRES ARE TO BE CLAMPED WITH CLAMP 10497-05-000 WITHIN 200 OF OUTLET BOXES, USE SCREW G67-10-12B.
1. ALL WIRES TO BE CLAMPED WITH CLAMP 10495-01-000 OR CLIP 80734-01-000 EVERY 600, USE SCREW G67-10-12B UNLESS OTHERWISE SPECIFIED.

- (29K) A/C ROOF-ONE 7,100 BTU
- (181) CODES STANDARDS/USA
- (14M) GENERATOR-3,000W-GENERAC GAS
- (12D) ELECTRICAL SYSTEM 30 AMP

| | | |
|--|-------|---|
| FOR ELECTRICAL TORQUE SPECIFICATIONS SEE DWG NO. 128783-01-000 | (X-X) | FOR ELECTRICAL CALLOUTS SEE DWG NO. 121339-01-000 |
|--|-------|---|

WINNEBAGO 99 22200

| OF IN | DATE | UNSPECIFIED TOLERANCES ARE: | MATERIAL |
|-------|------|-----------------------------|----------|
| DRP | DATE | WHOLE DIM (IN) | |
| DYE | DATE | ONE-PLACE (IN.XI) | |
| D/E | DATE | TWO-PLACE (IN.XXX) | |
| DATE | DATE | ANGLE | |
| DATE | DATE | THIRD ANGLE PROJECTION | |

DRWING INSTL-BODY (110130US)

SHEET 1 OF 12

130479

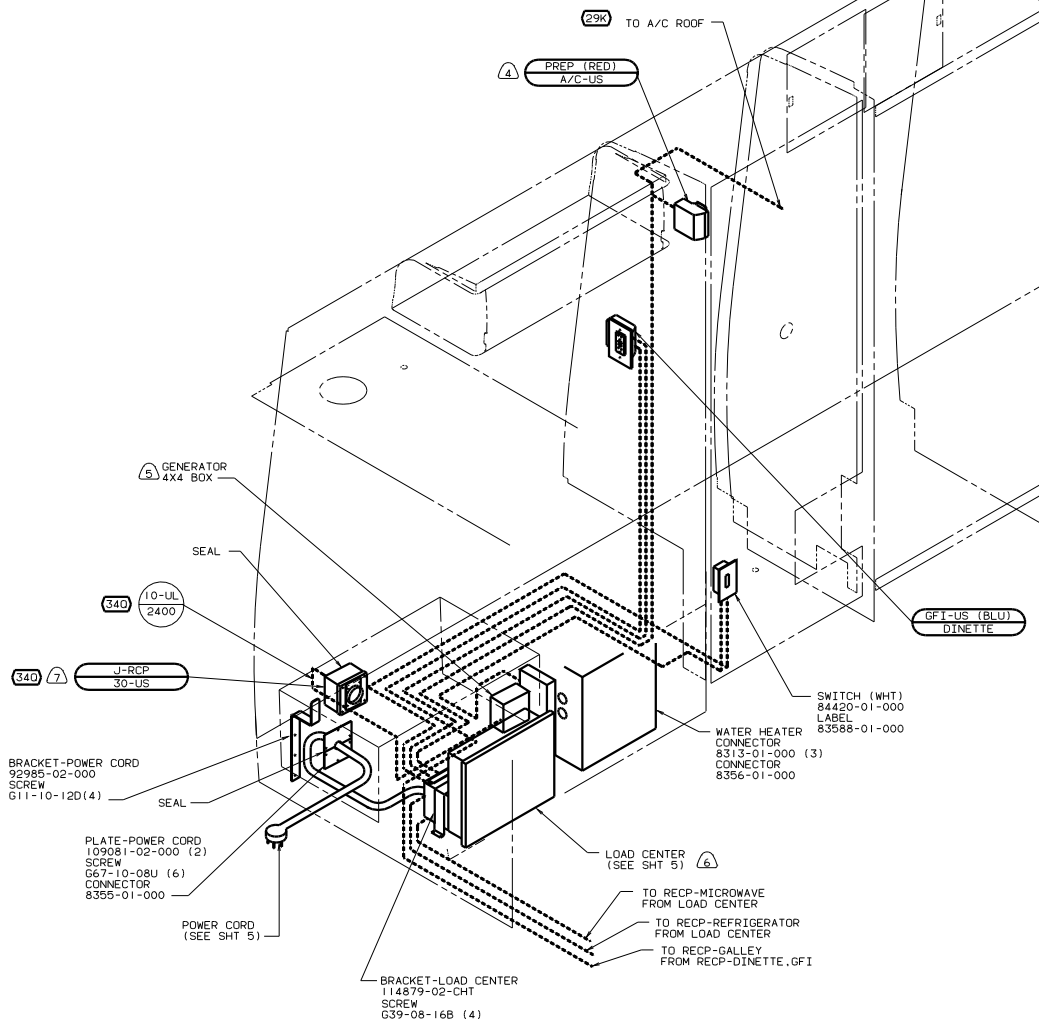

- 7) INSTALL RECP WITH GROUND TOWARD BOTTOM OF VEHICLE.
 - 6) LOCATE LOAD CENTER WITHIN DINETTE SEAT FACE.
 - 5) SEE GENERATOR INSTL FOR ADDITIONAL INFORMATION.
 - 4) NOT USED WITH 29K
3. ALL GROUND WIRES TO BE COVERED WITH TUBING 8041-02-000.
2. ALL WIRES ARE TO BE CLAMPED WITH CLAMP 10497-05-000 WITHIN 200 OF OUTLET BOXES. USE SCREW G67-10-12B.
1. ALL WIRES TO BE CLAMPED WITH CLAMP 10495-01-000 OR CLIP 80734-01-000 EVERY 600. USE SCREW G67-10-12B UNLESS OTHERWISE SPECIFIED.

NOTES:

- 340 GEN-3.0KW GENERAC 100V
- 29K A/C ROOF-ONE 7,100 BTU
- 12D ELECTRICAL SYSTEM 30 AMP
- 04L JAPAN EXPORT PACKAGE

FOR ELECTRICAL TORQUE SPECIFICATIONS SEE DWG NO. 128783-01-000

FOR ELECTRICAL CALLOUTS SEE DWG NO. 121339-01-000

99 2220D 04L 12D

| | |
|---------------|------------------------------|
| TITLE | WIRING INSTL-BODY(110130JPN) |
| NO. OF SHEETS | 2 OF 12 |
| SHEET NO. | 1 |
| DWG NO. | 130479 |

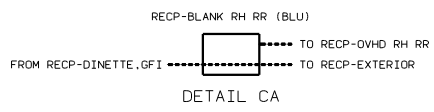
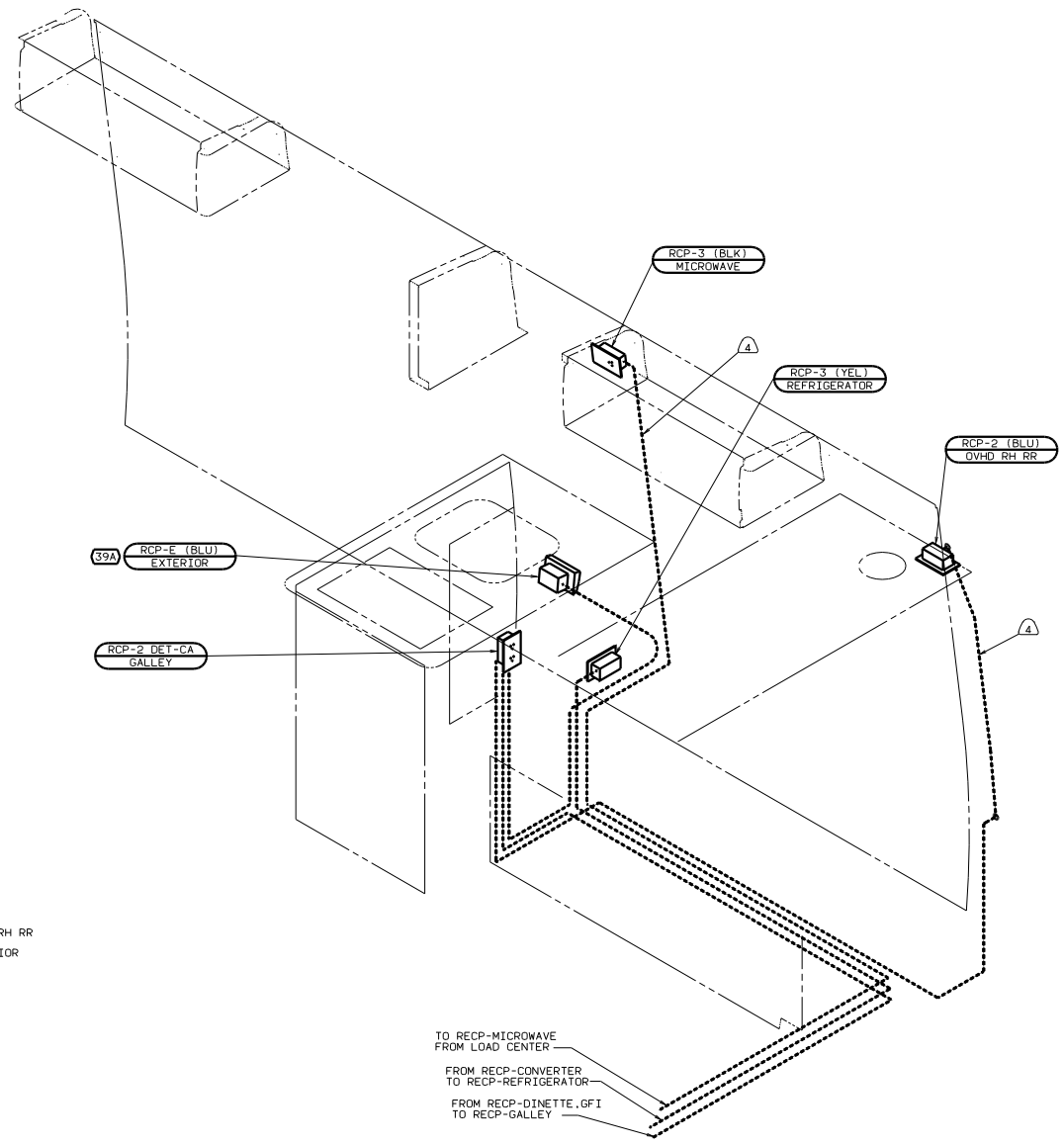

- 4 ROUTE WIRE THRU SIDEWALL.
- ALL GROUND WIRES TO BE COVERED WITH TUBING 8041-02-000.
 - ALL WIRES ARE TO BE CLAMPED WITH CLAMP 10497-05-000 WITHIN 200 OF OUTLET BOXES. USE SCREW G67-10-12B.
 - ALL WIRES TO BE CLAMPED WITH CLAMP 10495-01-000 OR CLIP 80734-01-000 EVERY 600. USE SCREW G67-10-12B UNLESS OTHERWISE SPECIFIED.

NOTES:

FOR ELECTRICAL TORQUE SPECIFICATIONS SEE DWG NO. 128783-01-000

(X-X)

FOR ELECTRICAL CALLOUTS SEE DWG NO. 121339-01-000

- (39A) EXT RECEPTACLE DPLX 120VAC
- (1B1) CODES STANDARDS/USA
- (12D) ELECTRICAL SYSTEM 30 AMP
- (04L) JAPAN EXPORT PACKAGE

99 2220D (1B1) (04L) (12D)

WIRING INSTL-BODY(11OR30US)
 SHEET 3 OF 12
 130479

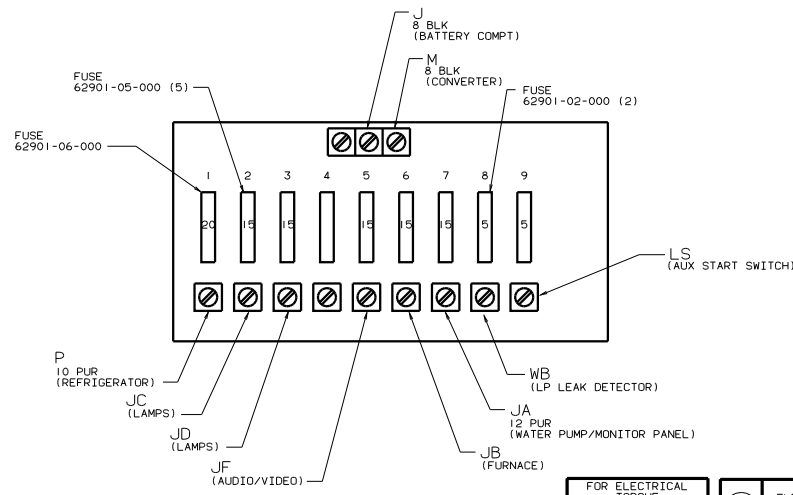
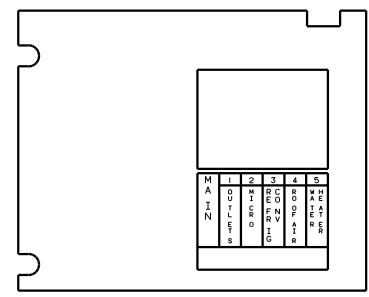
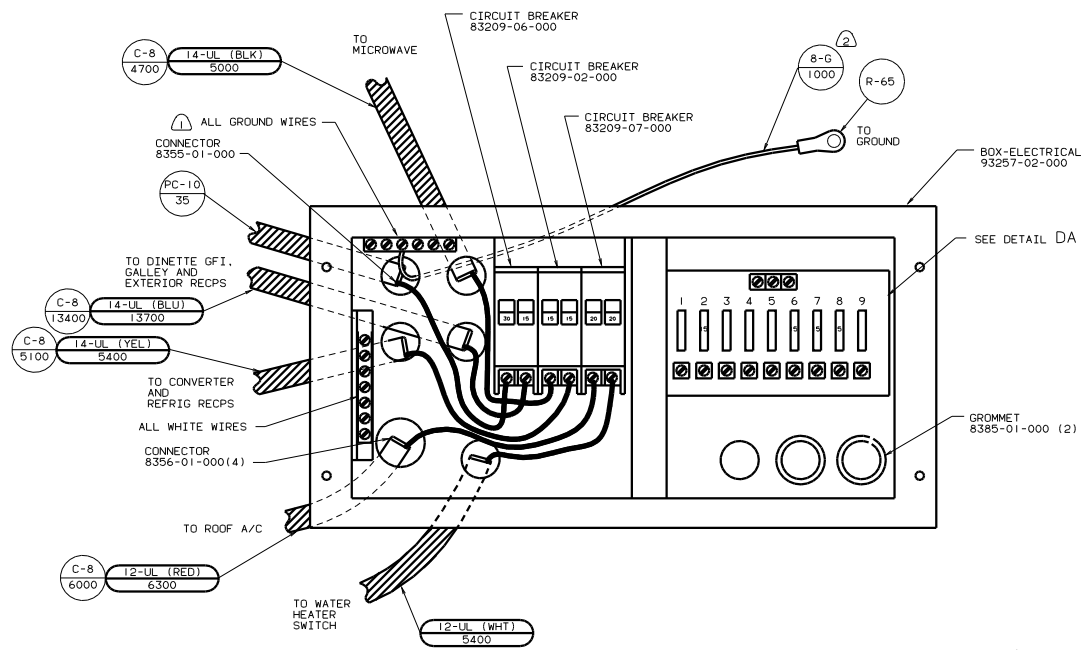

- ② SOLDER DIP STRIPED END OF 8GA WIRE.
- ⚠ ALL GROUND WIRES TO BE COVERED WITH TUBING 8041-02-000.

FOR ELECTRICAL TORQUE SPECIFICATIONS SEE DWG NO. 128783-01-000

FOR ELECTRICAL CALLOUTS SEE DWG NO. 121339-01-000

⑪① CODES STANDARDS/USA
 ⑪② ELECTRICAL SYSTEM 30 AMP
 99 2220D ⑪① ⑪②

| | | | |
|--------|-----|------------------------------|----|
| TITLE | | DRAWING INSTL-BODY(30 CC US) | |
| NO | REV | DATE | BY |
| 1 | | | |
| SHEET | | 4 OF 12 | |
| JOB NO | | 130479 | |

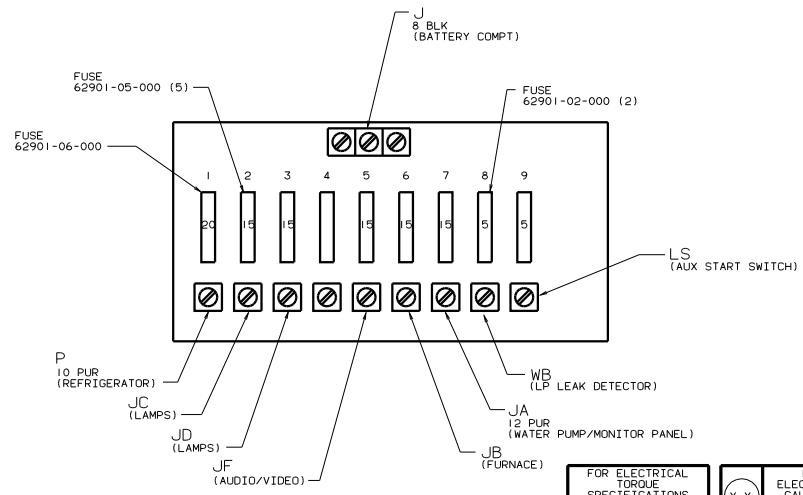
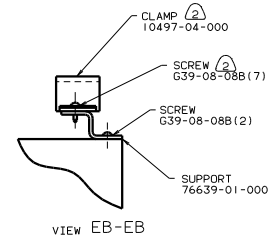
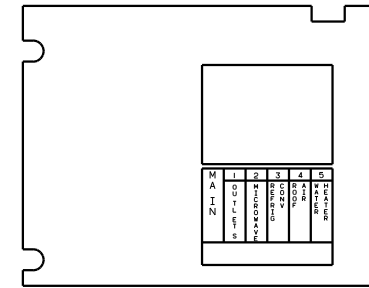
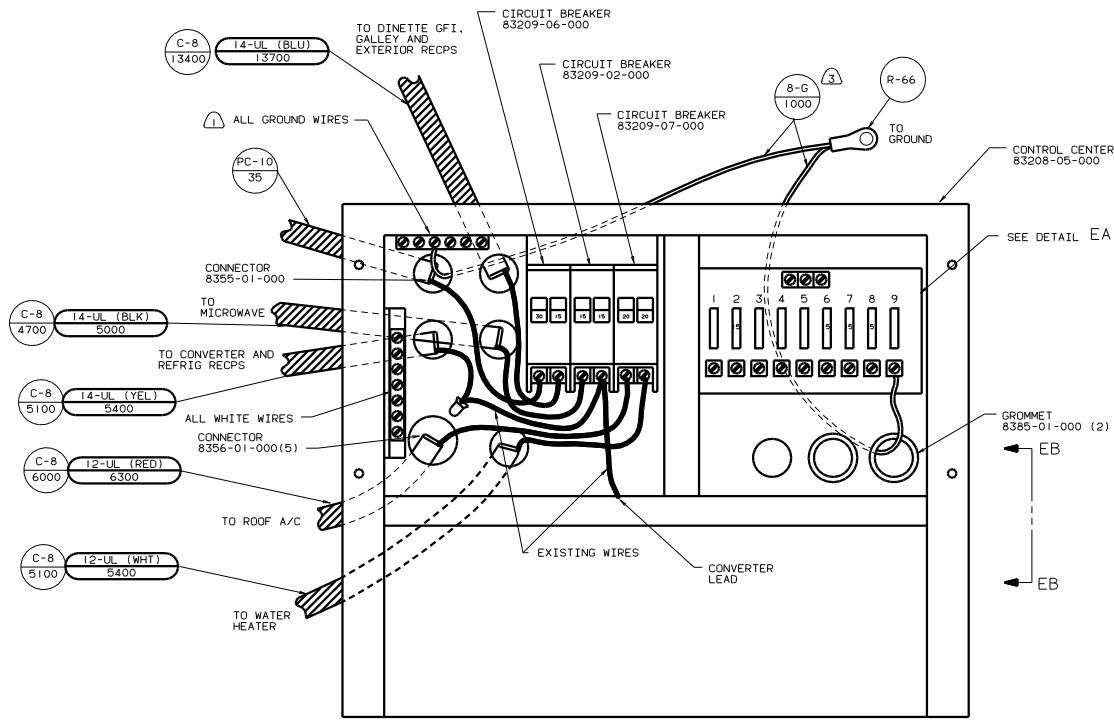

- ③ SOLDER DIP STRIPPED ENDS OF 8GA WIRES.
- ② FASTEN ALL WIRES TO SUPPORT. USE ONE SCREW PER CLAMP.
- ① ALL GROUND WIRES TO BE COVERED WITH TUBING 8041-02-000.

DETAIL EA

FOR ELECTRICAL TORQUE SPECIFICATIONS SEE DWG NO. 128783-01-000

FOR ELECTRICAL CALLOUTS SEE DWG NO. 121339-01-000

①20 ELECTRICAL SYSTEM 30 AMP

②4L JAPAN EXPORT PACKAGE

99 222QD ②4L ①20

WIRING INSTL-BODY(30 CC JPN)

130479

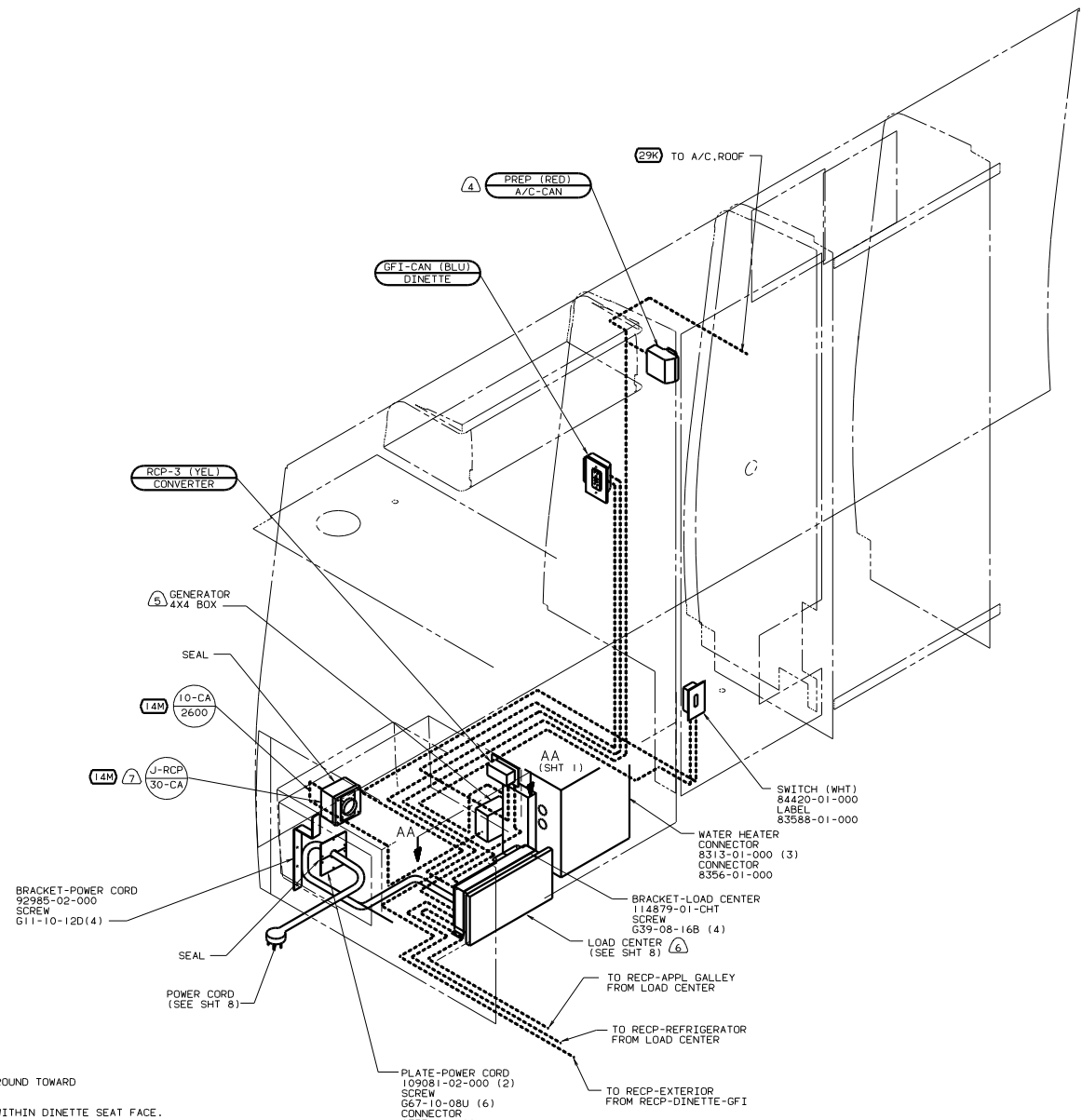

- (7) INSTALL RCP WITH GROUND TOWARD BOTTOM OF VEHICLE.
 - (6) LOCATE LOAD CENTER WITHIN DINETTE SEAT FACE.
 - (5) SEE GENERATOR INSTL FOR ADDITIONAL INFORMATION.
 - (4) NOT USED WITH (29K)
3. ALL GROUND WIRES TO BE COVERED WITH TUBING 8011-02-000.
2. ALL WIRES ARE TO BE CLAMPED WITH CLAMP 10497-05-000 WITHIN 200 OF OUTLET BOXES. USE SCREW 667-10-12B.
1. ALL WIRES TO BE CLAMPED WITH CLAMP 10495-01-000 OR CLIP 80734-01-000 EVERY 600. USE SCREW 667-10-12B UNLESS OTHERWISE SPECIFIED.

NOTES:

- (29K) A/C ROOF-ONE 7.100 BTU
 - (265) CODES/STANDARDS-CSA/CMVSS
 - (14M) GENERATOR-3.000W-GENERAC GAS
 - (12D) ELECTRICAL SYSTEM 30 AMP
- 99 2220D (265) (12D)

FOR ELECTRICAL TORQUE SPECIFICATIONS SEE DWG NO. 128783-01-000

FOR ELECTRICAL CALLOUTS SEE DWG NO. 121339-01-000

TITLE: WIRING INSTL-BODY(110130CAN)
 SHEET 6 OF 12
 130479

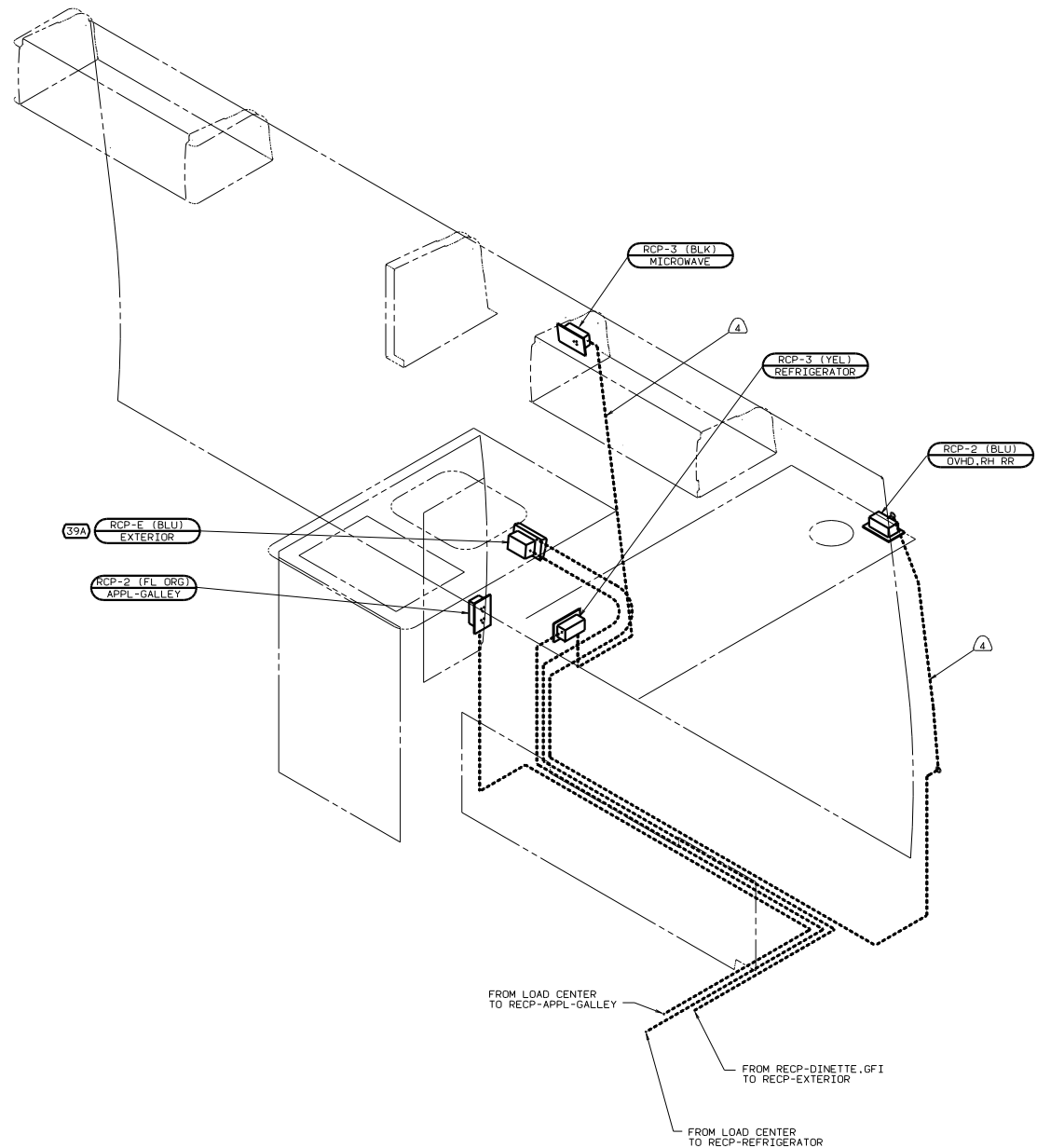

- △ ROUTE WIRE THRU SIDEWALL.
- 3. ALL GROUND WIRES TO BE COVERED WITH TUBING 8011-02-000.
- 2. ALL WIRES ARE TO BE CLAMPED WITH CLAMP 10497-05-000 WITHIN 200 OF OUTLET BOXES. USE SCREW G67-10-12B.
- 1. ALL WIRES TO BE CLAMPED WITH CLAMP 10495-01-000 OR CLIP 80734-01-000 EVERY 600. USE SCREW G67-10-12B UNLESS OTHERWISE SPECIFIED.

NOTES:

| | | |
|--|-------|---|
| FOR ELECTRICAL TORQUE SPECIFICATIONS SEE DWG NO. 128783-01-000 | (X-X) | FOR ELECTRICAL CALLOUTS SEE DWG NO. 121339-01-000 |
|--|-------|---|

(39A) EXT RECEPTACLE DPLX 120VAC
 (265) CODES/STANDARDS-CSA/CMVSS
 (120) ELECTRICAL SYSTEM 30 AMP

99 2220D (265) (120)
 TITLE: WIRING INSTL-BODY (L10R30CAN)
 SHEET 7 OF 12 FILE NO 130479

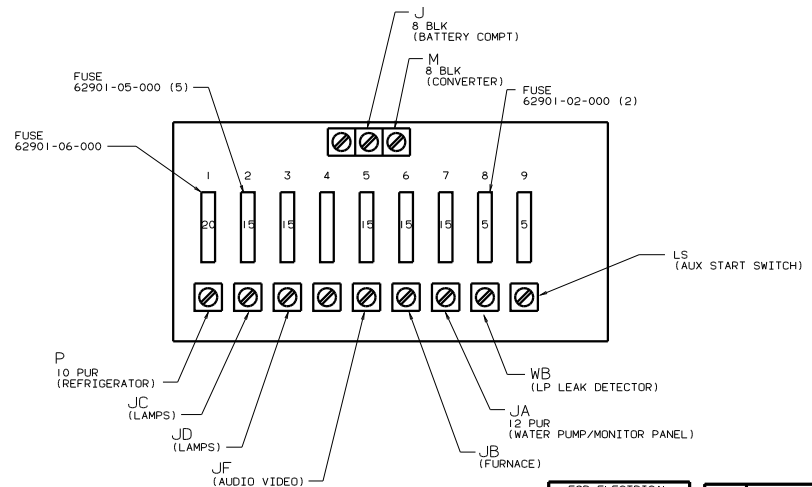
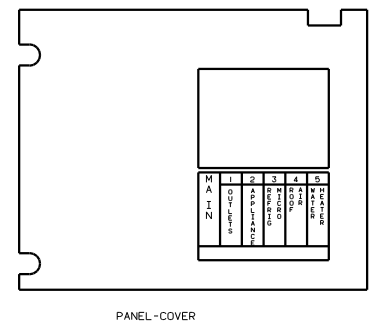
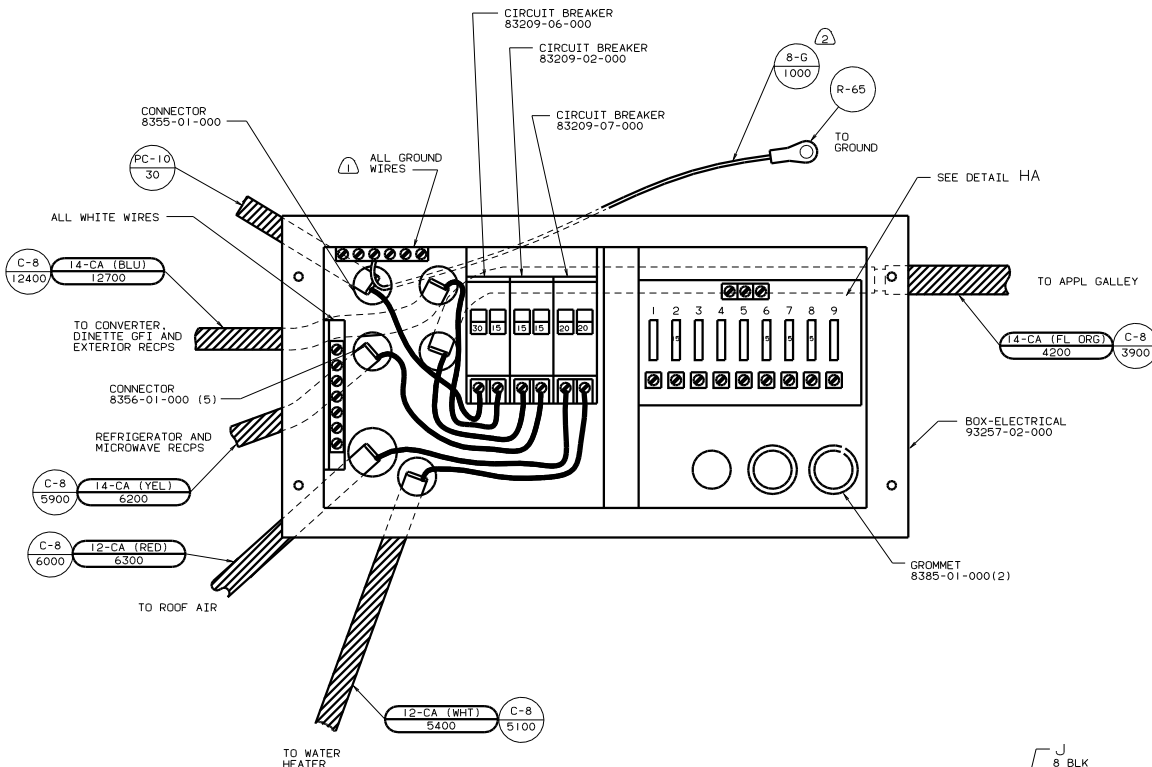

- 2 SOLDER DIP STRIPED END OF 8GA WIRE.
 1 ALL GROUND WIRES TO BE COVERED WITH TUBING 8041-02-000.

FOR ELECTRICAL TORQUE SPECIFICATIONS SEE DWG NO. 128783-01-000

FOR ELECTRICAL CALLOUTS SEE DWG NO. 121339-01-000

265 CODES/STANDARDS-CSA/CMVSS
 120 ELECTRICAL SYSTEM 30 AMP
 99 2220D 265 120

WIRING INSTL-BODY(30 CC CAN)
 SHEET 8 OF 12

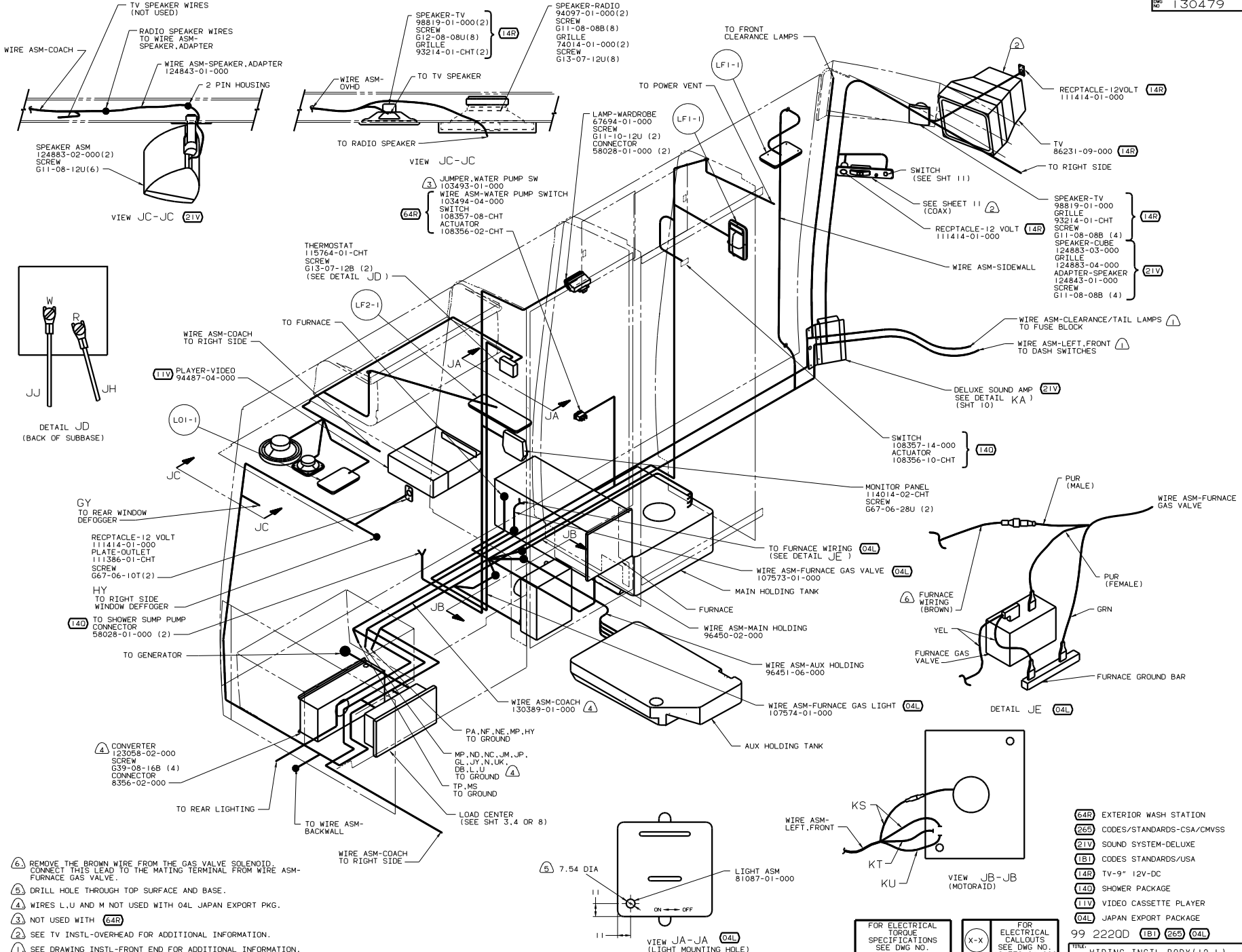

- ① SEE DRAWING INSTL-FRONT END FOR ADDITIONAL INFORMATION.
- ② SEE TV INSTL-OVERHEAD FOR ADDITIONAL INFORMATION.
- ③ NOT USED WITH 64R
- ④ WIRES L,U AND M NOT USED WITH 04L JAPAN EXPORT PKG.
- ⑤ DRILL HOLE THROUGH TOP SURFACE AND BASE.
- ⑥ REMOVE THE BROWN WIRE FROM THE GAS VALVE SOLENOID. CONNECT THIS LEAD TO THE MATING TERMINAL FROM WIRE ASM-FURNACE GAS VALVE.

FOR ELECTRICAL TORQUE SPECIFICATIONS SEE DWG NO. 128783-01-000

FOR ELECTRICAL CALLOUTS SEE DWG NO. 121339-01-000

- 64R EXTERIOR WASH STATION
- 265 CODES/STANDARDS-CSA/CMVSS
- 21V SOUND SYSTEM-DELUXE
- 1B1 CODES STANDARDS/USA
- 14R TV-9" 12V-DC
- 14D SHOWER PACKAGE
- 11V VIDEO CASSETTE PLAYER
- 04L JAPAN EXPORT PACKAGE

99 2220D 1B1 265 04L

WIRING INSTL-BODY(12 L)

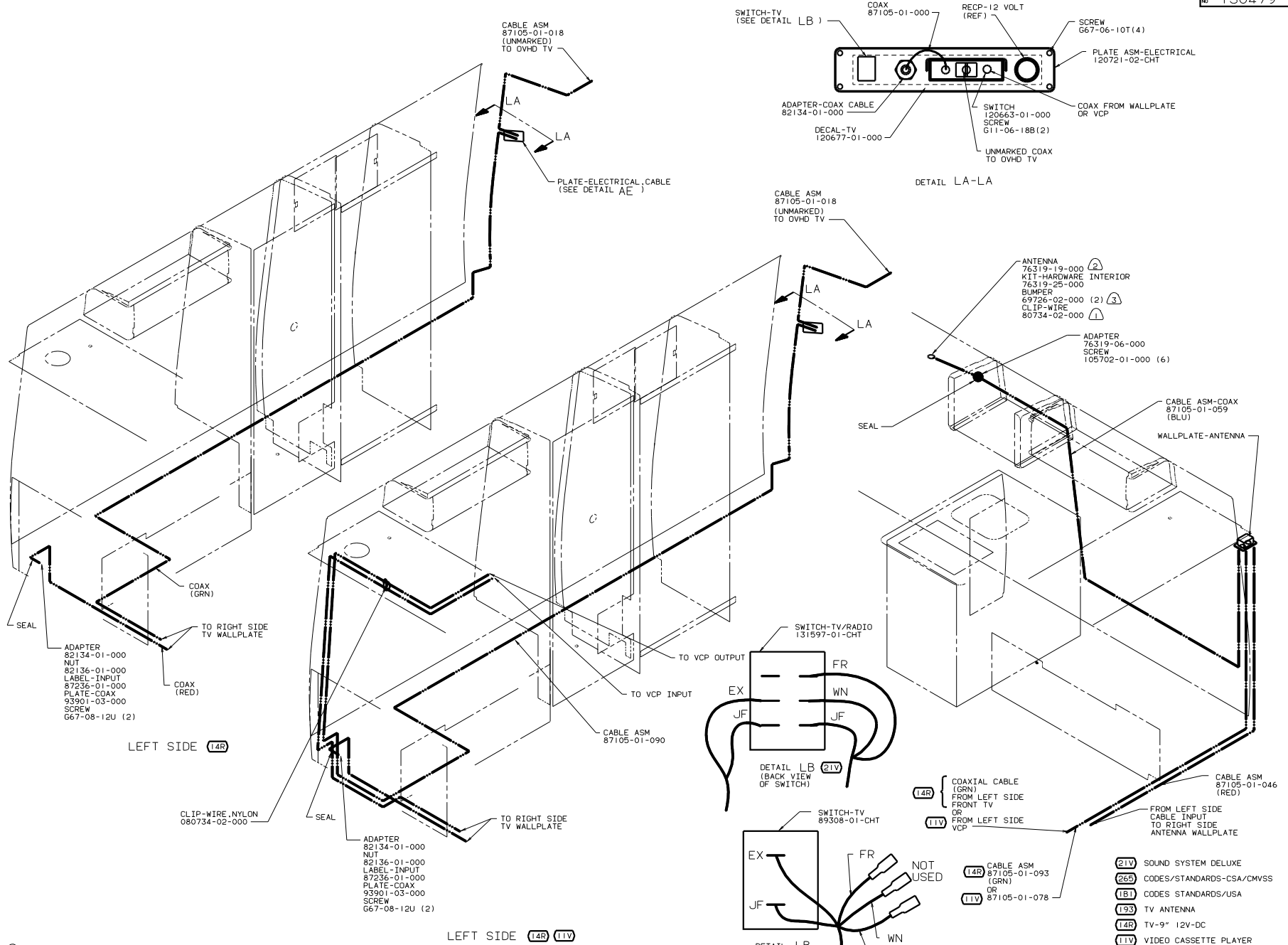

- ③ ADD RUBBER BUMPER TO ROOF UNDER EACH END OF ANTENNA IN DOWN POSITION WHICH MAY COME IN CONTACT WITH ROOF.
- ② SEE DRAWING 76319-01-000 FOR ADDITIONAL INFORMATION.
- ① LOCATE TO RETAIN CABLE BUT NOT RESTRICT TRAVEL OF ANTENNA.

FOR ELECTRICAL TORQUE SPECIFICATIONS SEE DWG NO. 128783-01-000

- ②1V SOUND SYSTEM DELUXE
- ②6S CODES/STANDARDS-CSA/CMVSS
- ①B1 CODES STANDARDS/USA
- ①93 TV ANTENNA
- ①4R TV-9" 12V-DC
- ①1V VIDEO CASSETTE PLAYER
- ①4L JAPAN EXPORT PACKAGE

99 2220D (1B1) (26S) (04L)
 TITLE: WIRING INSTL-BODY(COAX)
 SHEET 11 OF 12

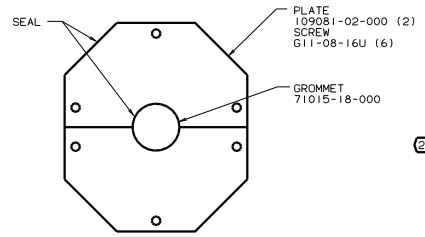

- 29K AIR CONDITIONER 93306-01-CHT 93306-02-CHT 93307-03-000
- 39V CEILING ASM 102289-01-000 (4)

- LAMP-CLEARANCE, AMBER 113709-01-000 (5)
- SCREW 611-08-12T (10)

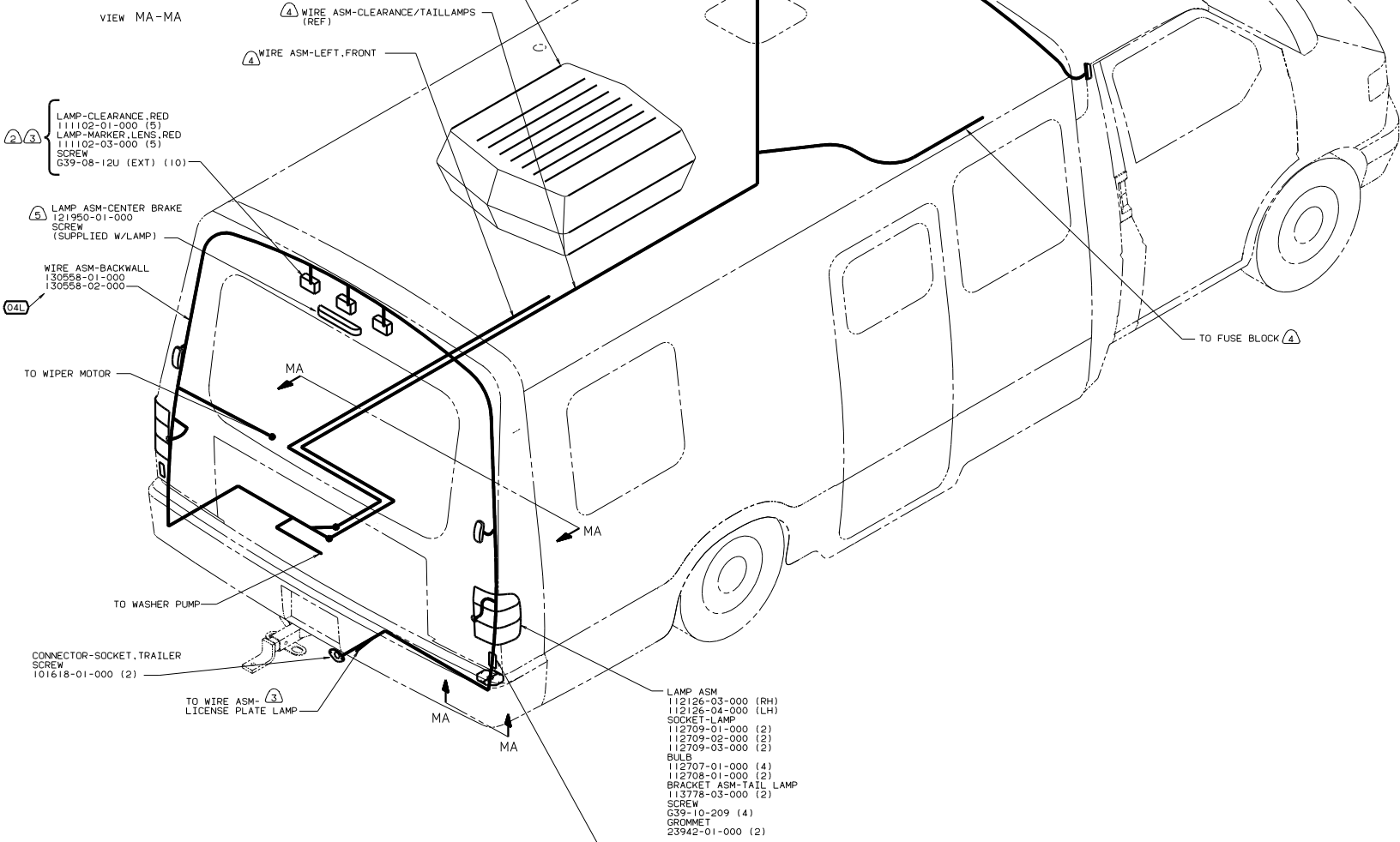

- 5) NOT USED WITH 04L
 - 4) SEE WIRING INSTL-FRONT END FOR ADDITIONAL INFORMATION.
 - 3) DELETE ALL CLEARANCE LAMPS WITH 04L
 - 2) LOCATE ON CENTER OF HOLE IN CAP ASM-REAR.
1. CONNECTOR-PLUG, TRAILER 113589-01-000 TO BE SUPPLIED LOOSE IN COACH WITH TRAILER TOW PACKAGE.

04L

- 39V EXPORT ROOF AIR-7.00 BTU, 220VAC
 - 29K A/C ROOF-ONE 7,100 BTU
 - 265 CODES/STANDARDS-CSA/CMVSS
 - 181 CODES STANDARDS/USA
 - 04L JAPAN EXPORT PACKAGE
- 99 222QD 181 265 04L

FOR ELECTRICAL TORQUE SPECIFICATIONS SEE DWG NO. 128783-01-000

| | |
|---------------|-------------------------|
| TITLE | WIRING INSTL-BODY(EX L) |
| NO. OF SHEETS | 12 |
| SHEET NO. | 12 OF 12 |
| REV | 1.0 |
| DATE | 130479 |