



**DANGER**

**Danger of electrical shock, burns or death.** Always remove all power sources before attempting any repair, service or diagnostic work. Power can be present from shore power, generator, inverter or battery. All power sources must be disabled and secured before performing any service.



**CAUTION**

If you lack the skills, tools or equipment to perform diagnostic or repair work leave such work to an authorized Winnebago Industries dealer or other qualified shop.

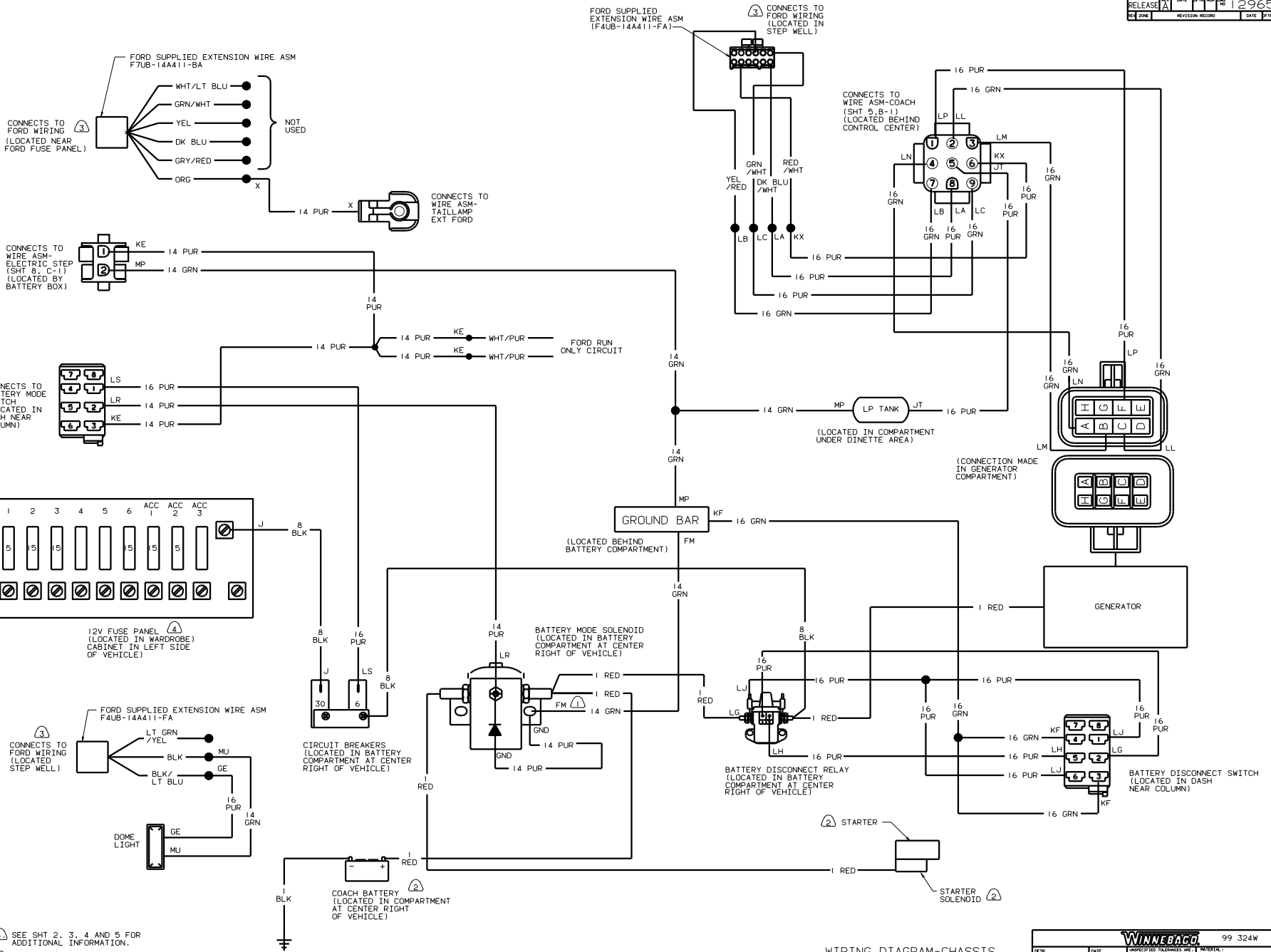

- ④ SEE SH2, 3, 4 AND 5 FOR ADDITIONAL INFORMATION.
- ③ SEE MANUFACTURER'S DIAGRAM FOR ADDITIONAL INFORMATION.
- ② CHASSIS SUPPLIED.
- ① WIRE FM ATTACHES TO SOLENOID MOUNTING BOLT.

WIRING DIAGRAM-CHASSIS  
(WIRE ASM 129977)  
(FORD)

WINNEBAGO		99 324W
DATE	UNDESIGNATED TOLERANCES ARE:	MATERIAL
DATE	WHOLE SIZE (IN)	
DATE	ONE-PLACE (IN)	
DATE	TWO-PLACE (IN)	
DATE	THREE-PLACE (IN)	
DATE	FOUR-PLACE (IN)	
DATE	FIVE-PLACE (IN)	
DATE	SIX-PLACE (IN)	
DATE	SEVEN-PLACE (IN)	
DATE	EIGHT-PLACE (IN)	
DATE	NINE-PLACE (IN)	
DATE	TEN-PLACE (IN)	
DATE	ELEVEN-PLACE (IN)	
DATE	TWELVE-PLACE (IN)	
DATE	THIRTY-PLACE (IN)	
DATE	FOURTY-PLACE (IN)	
DATE	FIFTY-PLACE (IN)	
DATE	SIXTY-PLACE (IN)	
DATE	SEVENTY-PLACE (IN)	
DATE	EIGHTY-PLACE (IN)	
DATE	NINETY-PLACE (IN)	
DATE	ONE HUNDRED-PLACE (IN)	
DATE	TWO HUNDRED-PLACE (IN)	
DATE	THREE HUNDRED-PLACE (IN)	
DATE	FOUR HUNDRED-PLACE (IN)	
DATE	FIVE HUNDRED-PLACE (IN)	
DATE	SIX HUNDRED-PLACE (IN)	
DATE	SEVEN HUNDRED-PLACE (IN)	
DATE	EIGHT HUNDRED-PLACE (IN)	
DATE	NINE HUNDRED-PLACE (IN)	
DATE	TEN HUNDRED-PLACE (IN)	

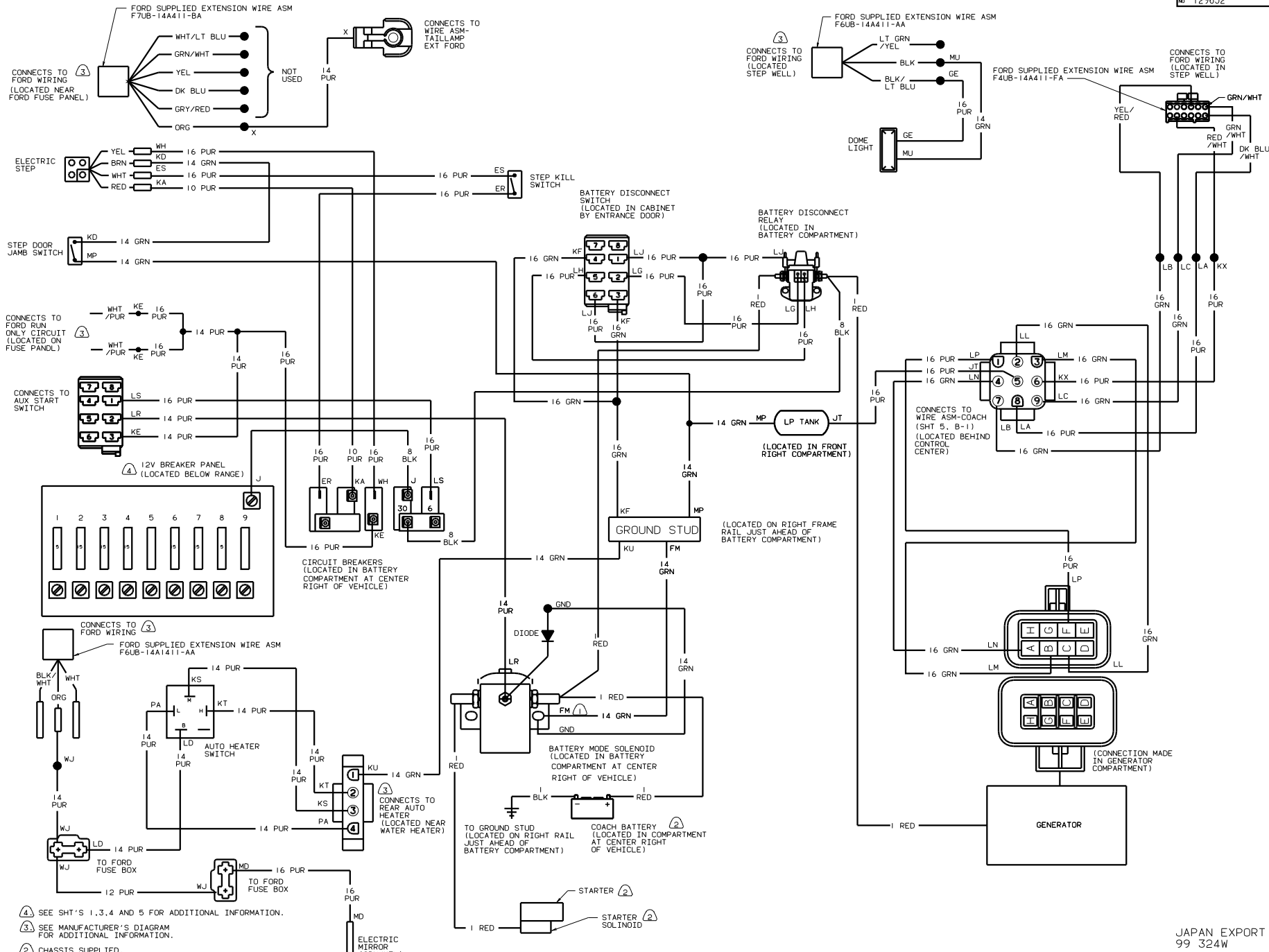

- ① SEE SHT'S 1, 3, 4 AND 5 FOR ADDITIONAL INFORMATION.
- ③ SEE MANUFACTURER'S DIAGRAM FOR ADDITIONAL INFORMATION.
- ② CHASSIS SUPPLIED.
- ① WIRE FM ATTACHES TO SOLENOID MOUNTING BOLT.

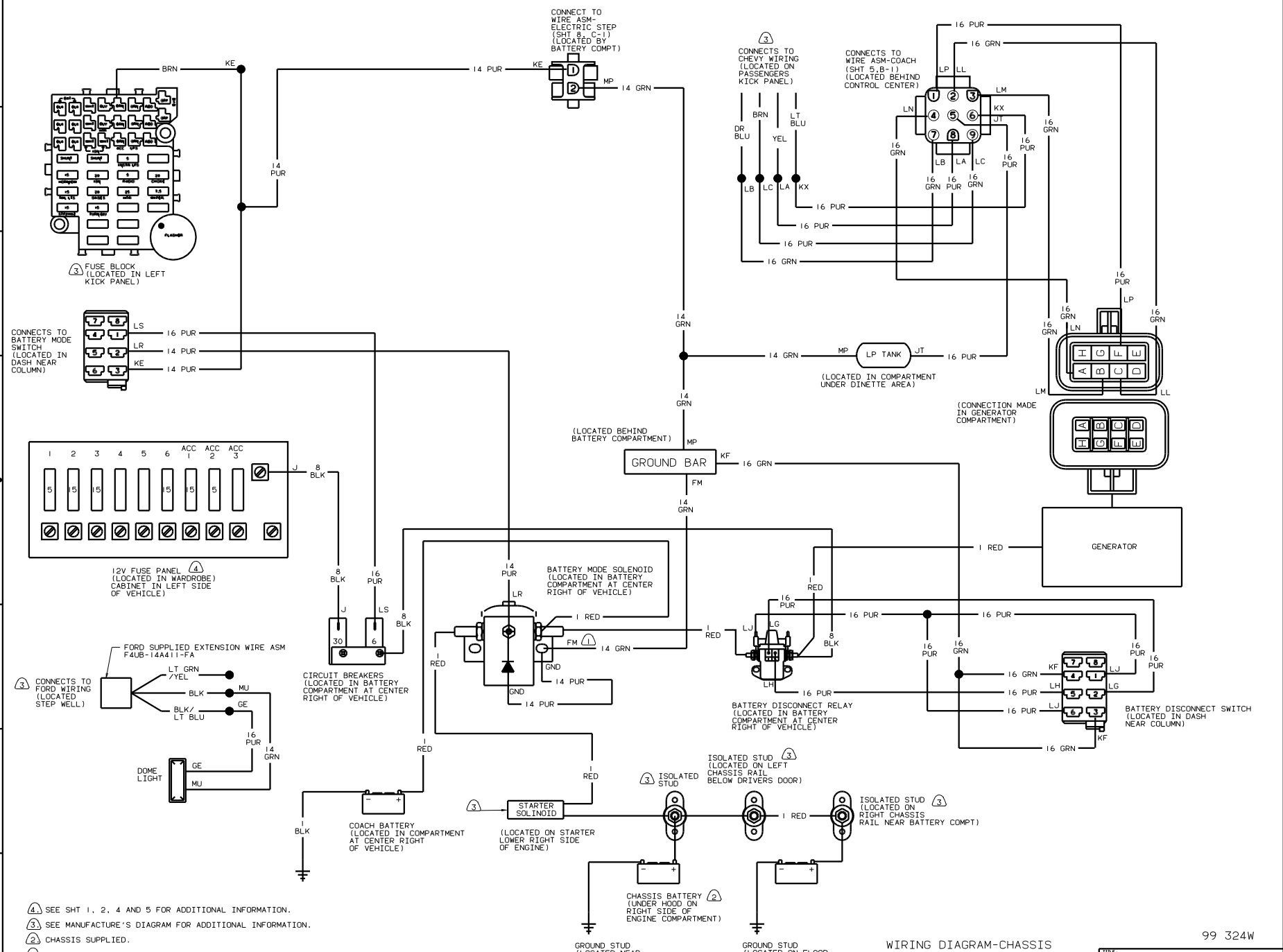

4. SEE SH1 1, 2, 4 AND 5 FOR ADDITIONAL INFORMATION.  
 3. SEE MANUFACTURE'S DIAGRAM FOR ADDITIONAL INFORMATION.  
 2. CHASSIS SUPPLIED.  
 1. WIRE FM ATTACHES TO SOLENOID MOUNTING BOLT.

WIRING DIAGRAM-CHASSIS  
 (WIRE ASM 129976)  
 (GM)

99 324W

FIG. NO.	129652
TITLE	WIRING DIAGRAM-BODY 12V
NO. OF SHEETS	8
SHEET NO.	3
DATE	
BY	
CHKD	
APP'D	
129652	

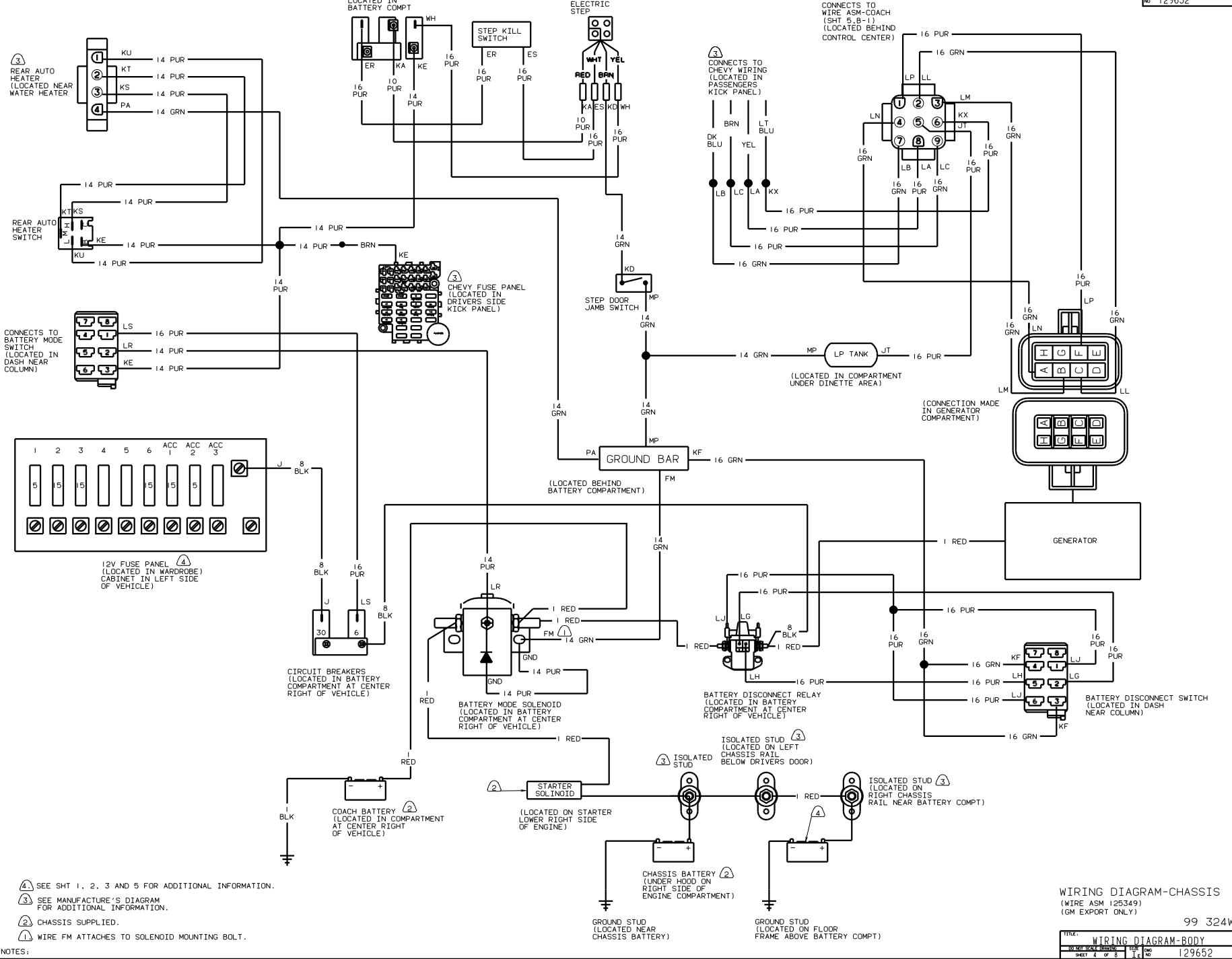

④ SEE SHT 1, 2, 3 AND 5 FOR ADDITIONAL INFORMATION.  
 ③ SEE MANUFACTURE'S DIAGRAM FOR ADDITIONAL INFORMATION.  
 ② CHASSIS SUPPLIED.  
 ① WIRE FM ATTACHES TO SOLENOID MOUNTING BOLT.

WIRING DIAGRAM-CHASSIS  
 (WIRE ASM 125349)  
 (GM EXPORT ONLY)

TITLE:		WIRING DIAGRAM-BODY	
NO. THIS SHEET CONTAINS:	REV.:	DATE:	
1	1		
SHEET:		4 OF 8	
DWG. NO.:		129652	

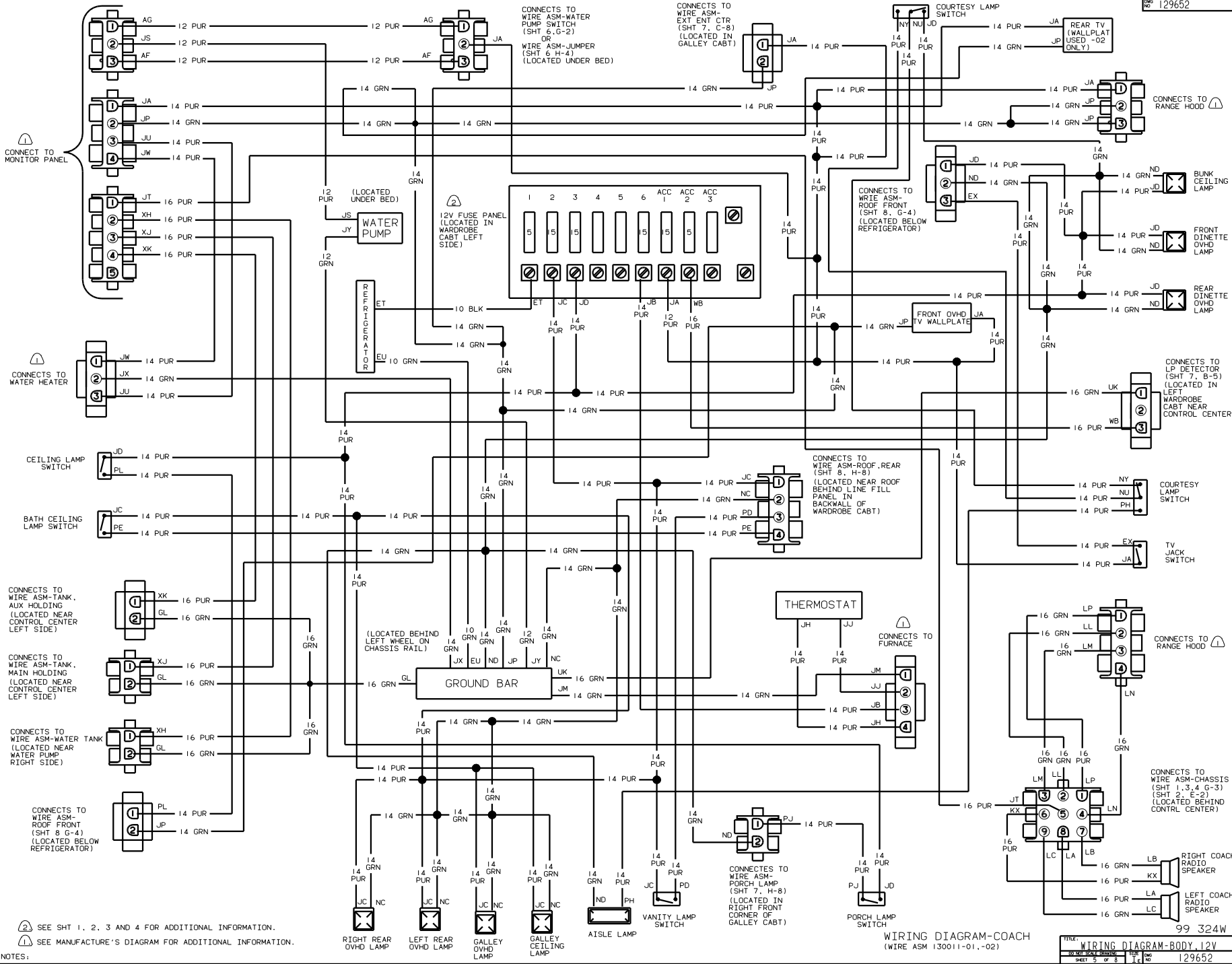

SEE SHT 1, 2, 3 AND 4 FOR ADDITIONAL INFORMATION.  
 SEE MANUFACTURER'S DIAGRAM FOR ADDITIONAL INFORMATION.

WIRING DIAGRAM-COACH  
 (WIRE ASM 130011-01, -02)

TITLE:	WIRING DIAGRAM-BODY 12V
NO. OF SHEETS:	8
SHEET NO.:	5
DATE:	129652

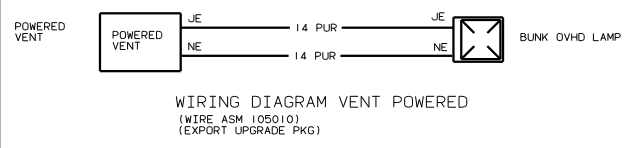
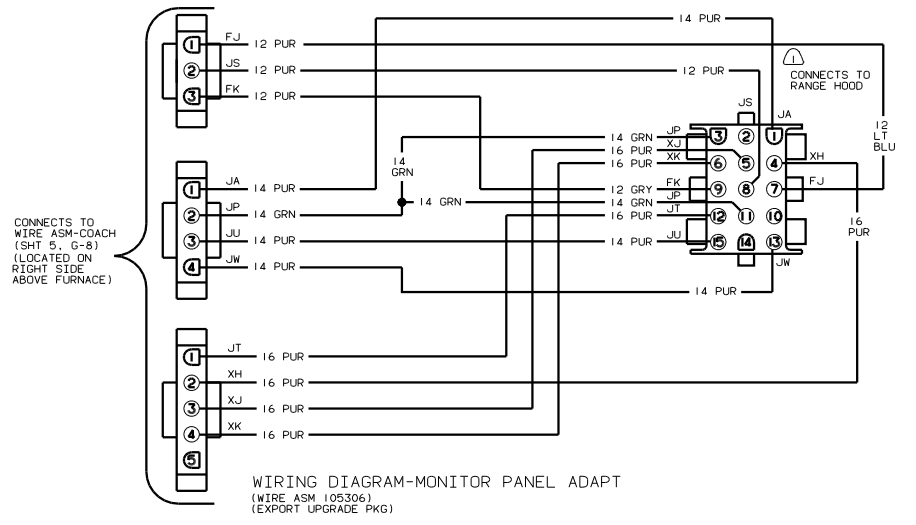
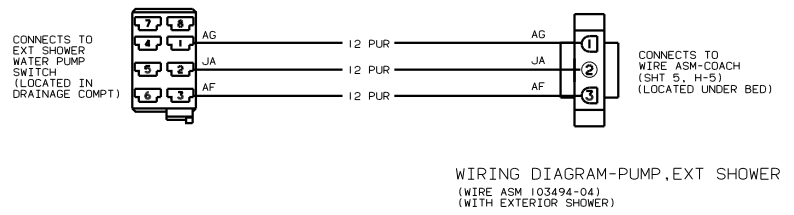
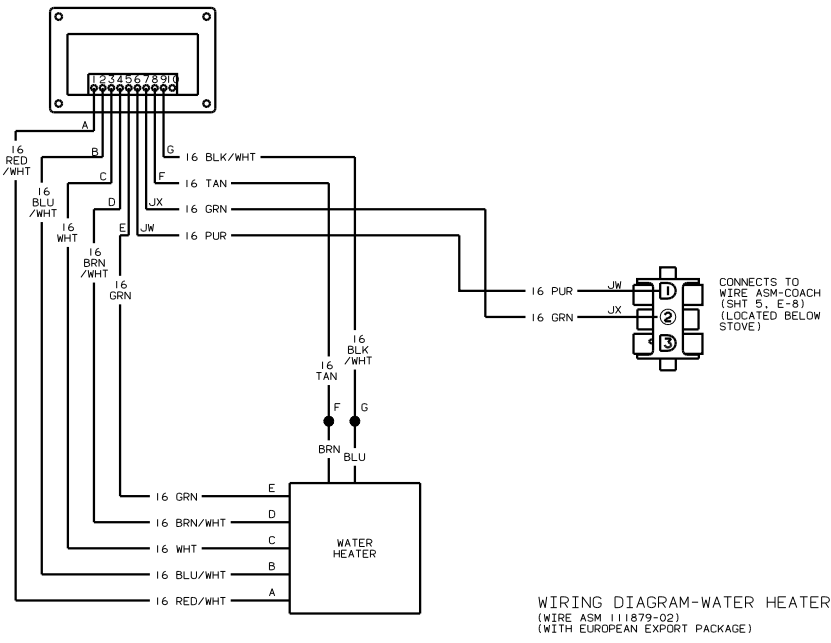
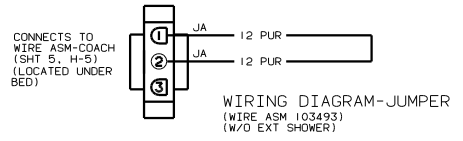
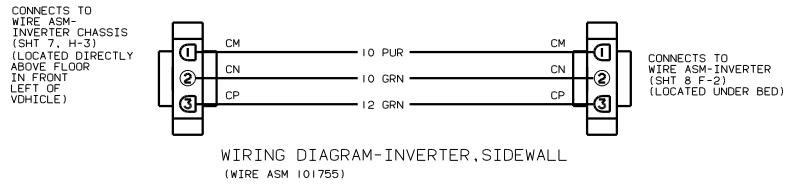

SEE MANUFACTURER'S DIAGRAM FOR ADDITIONAL INFORMATION.

NOTES:

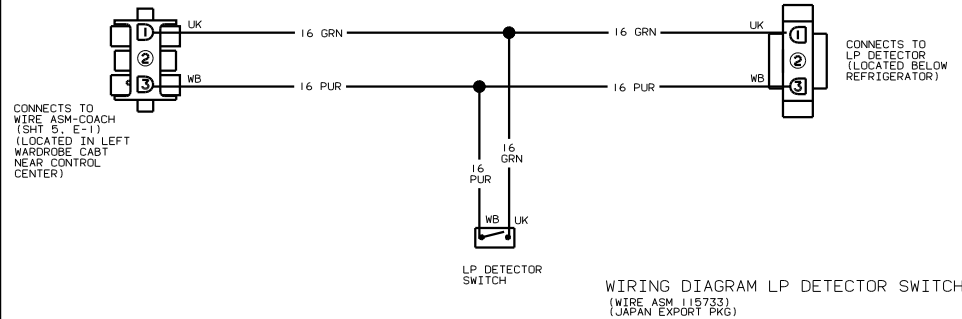
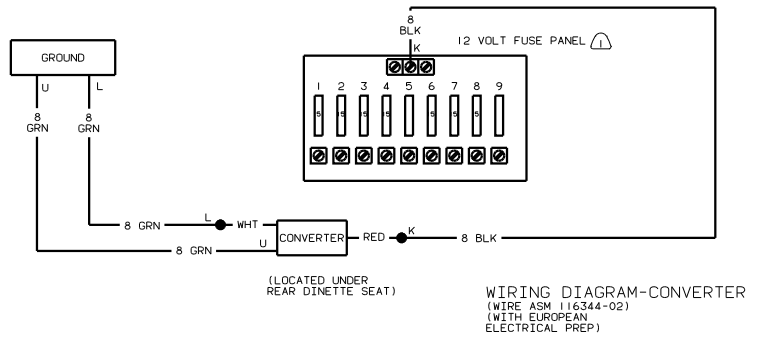
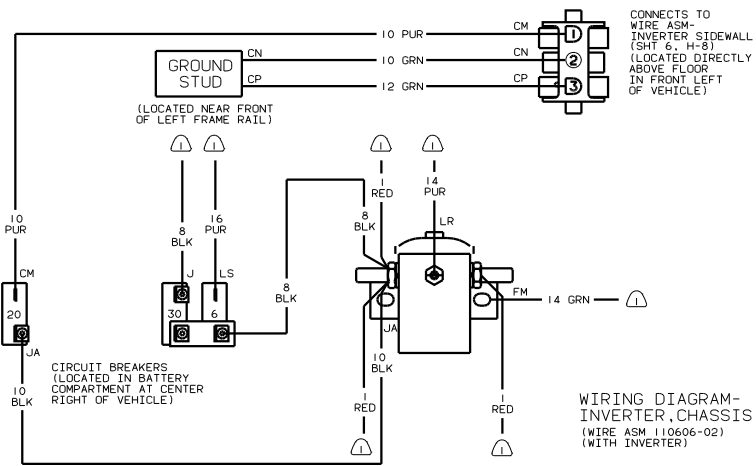
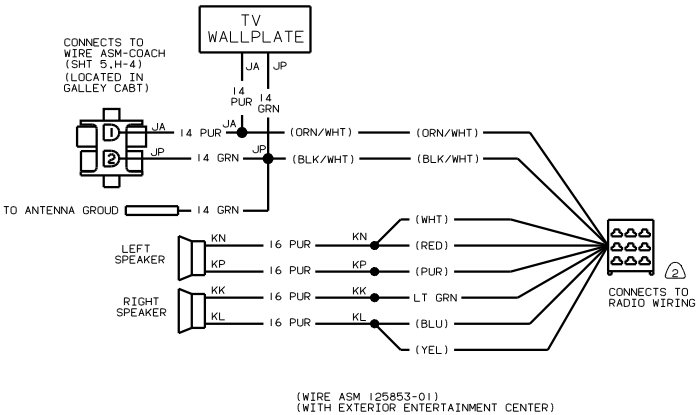
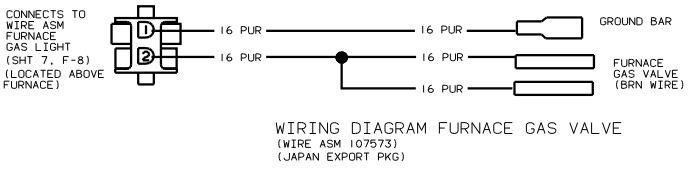
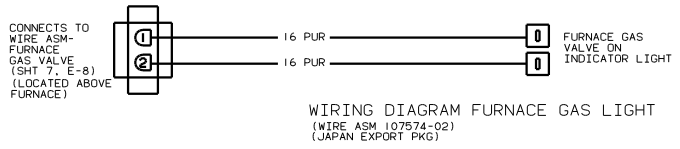
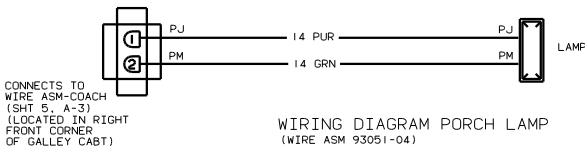

② SEE MANUFACTURER'S DIAGRAM FOR ADDITIONAL INFORMATION.  
① SEE WIRING DIAGRAM-AUTO LAMPS FOR ADDITIONAL INFORMATION.

NOTES:



