



DANGER

Danger of electrical shock, burns or death. Always remove all power sources before attempting any repair, service or diagnostic work. Power can be present from shore power, generator, inverter or battery. All power sources must be disabled and secured before performing any service.



CAUTION

If you lack the skills, tools or equipment to perform diagnostic or repair work leave such work to an authorized Winnebago Industries dealer or other qualified shop.

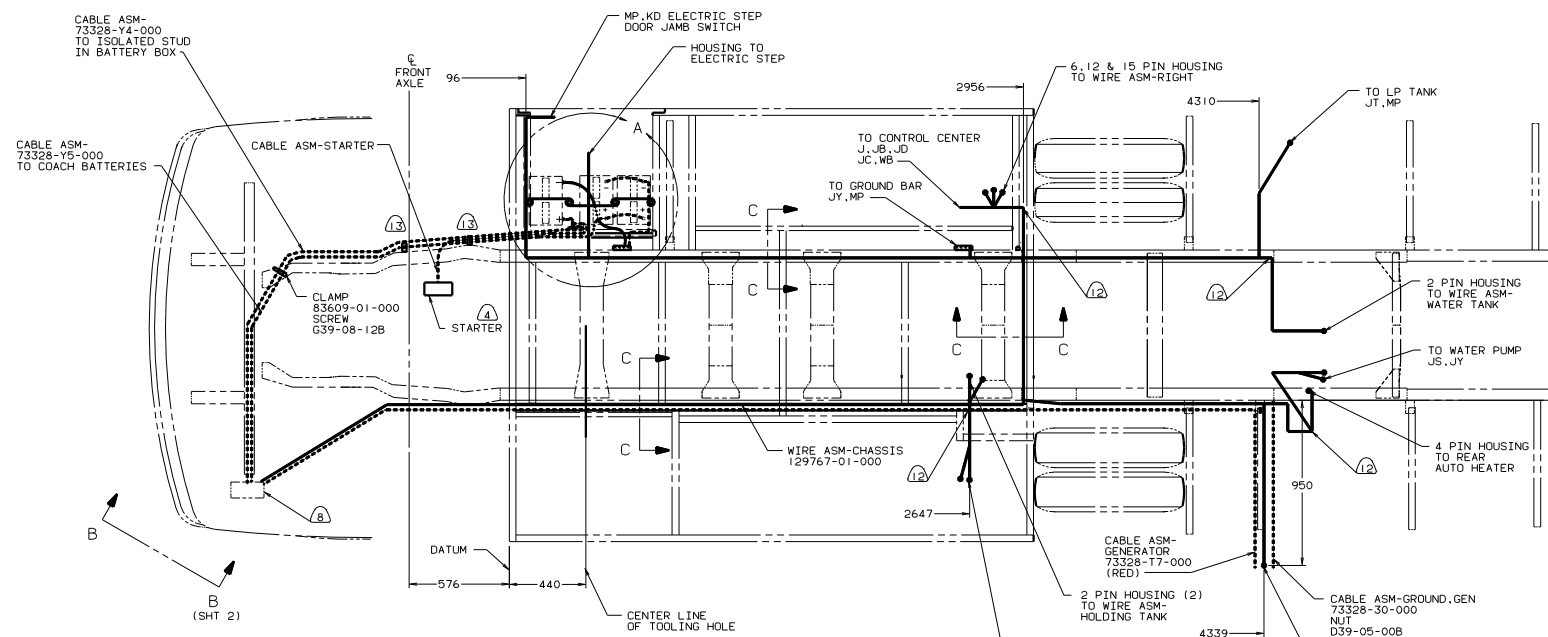
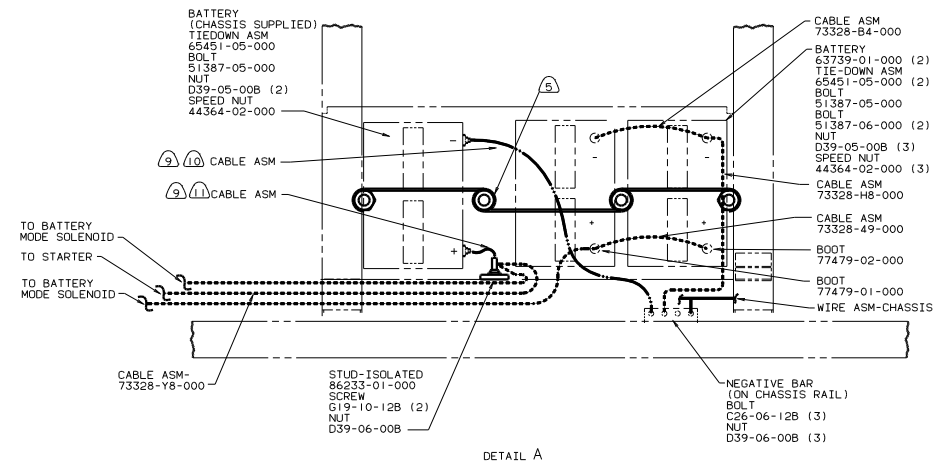

- (11) TRIM CABLE TO 400 MM. ADD TERMINAL 8348-01-000.
 - (10) TRIM CABLE TO 600 MM. ADD TERMINAL 8348-02-000.
 - (9) SUPPLIED WITH CHASSIS.
 - (8) SEE WIRING INSTL-FRONT END FOR ADDITIONAL INFORMATION.
 - (7) TRIM OFF EXCESS WIRE TIE.
 - (6) COVER EDGE OF HOLE THROUGH BATTERY BOX WITH TRIM-VINYL 72368-02-000.
 - (5) USE TWO NUTS HERE TO ACCOUNT FOR BATTERY HEIGHT DIFFERENCE.
 - (4) BATTERY CABLE MUST BE INSTALLED TO STARTER MOTOR BEFORE ENGINE WIRING HARNESS AND ROUTED IN SUCH A MANNER AS TO PREVENT ANY POSSIBLE DEGRADATION FROM EXHAUST SYSTEM.
 - (3) WIRE TIE 8343-02-000. FASTEN TO FLOOR ASM FRAME TUBE AT LEAST ONCE EVERY 600MM.
2. SECURE CONDUIT 41953-01-000, 41953-02-000 AND 41953-03-000 OVER ALL WIRES IN CONTACT WITH SHARP EDGES.
1. LEGEND: — WINNEBAGO, CABLE, - - - CHASSIS SUPPLIED.

- (13) WIRE TIE 116673-01-000.
- (12) WIRES TO BE ROUTED THRU FLOOR IN THIS LOCATION IN MHP.

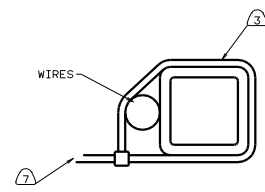

FOR ELECTRICAL TORQUE SPECIFICATIONS SEE DWG NO. 128783-01-000

OF IN		DATE	UNSPECIFIED TOLERANCES ARE:	WINNEBAGO 99 F26P
CHP	DATE	WHOLE DIM (1)	7.0	
DFE	DATE	ONE-PLACE (1)	1	
DVE	DATE	TWO-PLACE (1)	1	
COMB	DATE	THREE-PLACE (1)	1	
TITLE		DATE	THRU WHOLE PRODUCTION	
DRAWING NO.		DATE	129646	
SHEET		1 OF 2		
SCALE		NOTE	ALL DIMENSIONS ARE IN MILLIMETERS	
REF:		127319 F I		

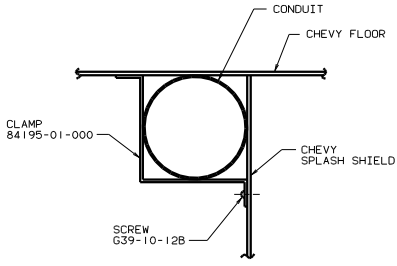

VIEW D-D

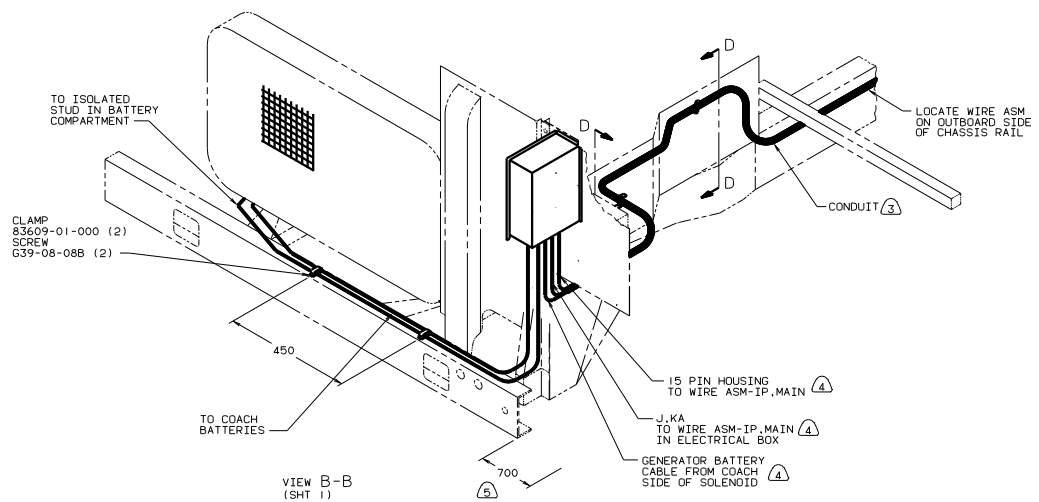

- 5 LAY BATTERY AND GENERATOR CABLES TO THIS DIMENSION FROM END OF CHASSIS CROSSMEMBER TO START INSTALLATION.
- 4 SEE WIRING INSTL-FRONT END FOR ADDITIONAL INFORMATION.
- 3 COVER WITH CONDUIT 41953-09,-10,-11-000 AS REQUIRED.
2. SECURE CONDUIT 41953-01-000, 41953-02-000 AND 41953-03-000 OVER ALL WIRES IN CONTACT WITH SHARP EDGES.
1. LEGEND: — WINNEBAGO, CABLE, — CHASSIS SUPPLIED.

FOR ELECTRICAL TORQUE SPECIFICATIONS SEE DWG NO. 128783-01-000

99 F26P

TITLE		129646	
WIRING INSTL-CHASSIS			
NO. OF SHEETS	TOTAL SHEETS	REV.	DATE
2	2	1	