



DANGER

Danger of electrical shock, burns or death. Always remove all power sources before attempting any repair, service or diagnostic work. Power can be present from shore power, generator, inverter or battery. All power sources must be disabled and secured before performing any service.



CAUTION

If you lack the skills, tools or equipment to perform diagnostic or repair work leave such work to an authorized Winnebago Industries dealer or other qualified shop.

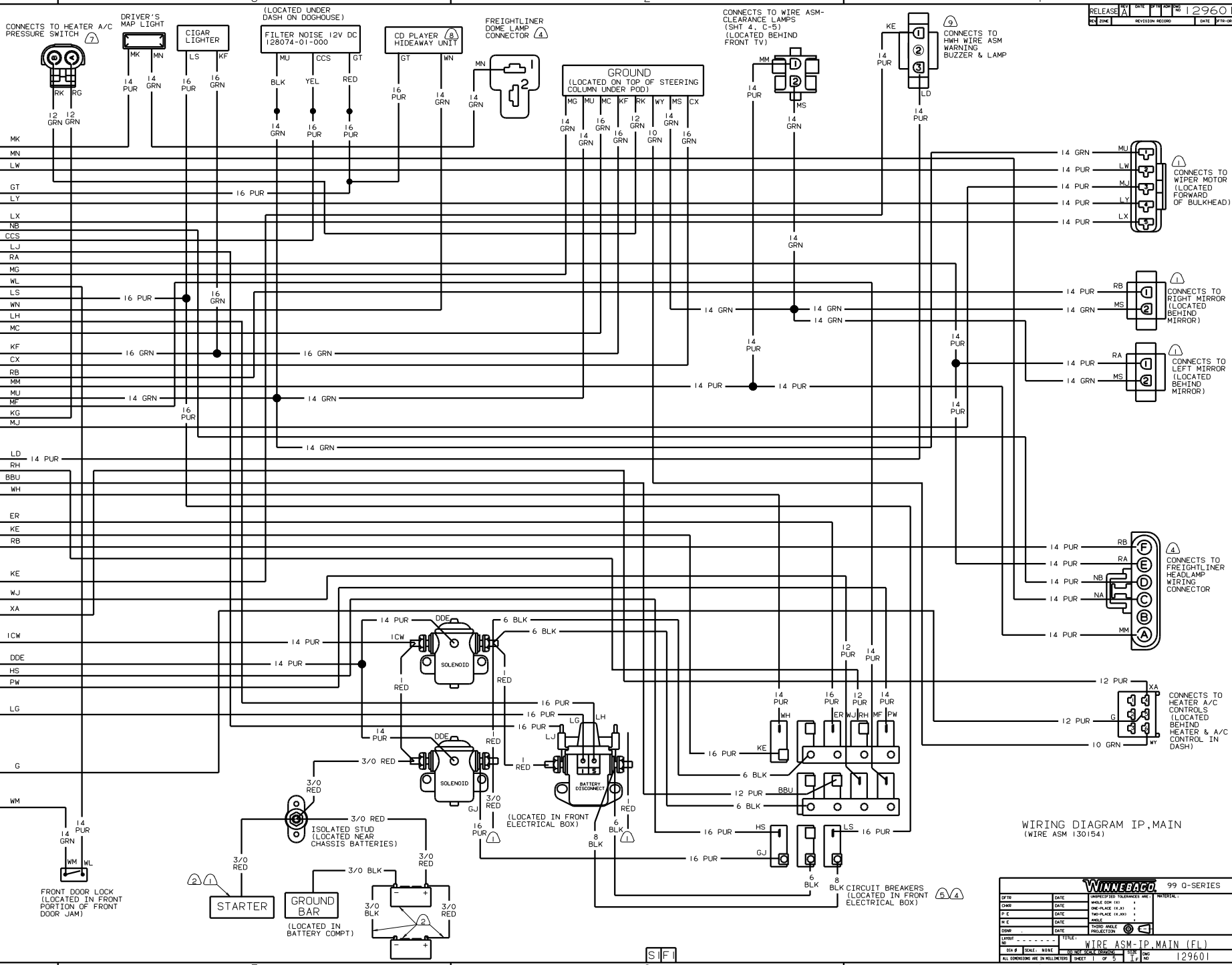

WIRING DIAGRAM IP, MAIN (WIRE ASM 130154)

WINNEBAGO 99 0-SERIES			
DPTD	DATE	APPROVED (RELEASED) BY	MATERIAL
CHWD	DATE	MANUFACTURED BY (PL)	
PE	DATE	INSPECTION BY (PL)	
WTE	DATE	WELD	
WC	DATE	THIRD WELD	
DWD	DATE	PROTECTION	
LIGHT	DATE	TITLE	
DR #	SCALE	WIRE	WIRE - ASM - IP, MAIN (FL)
ALL DIMENSIONS ARE IN MILLIMETERS		SHEET	1 OF 5
REV		NO	129601

129601

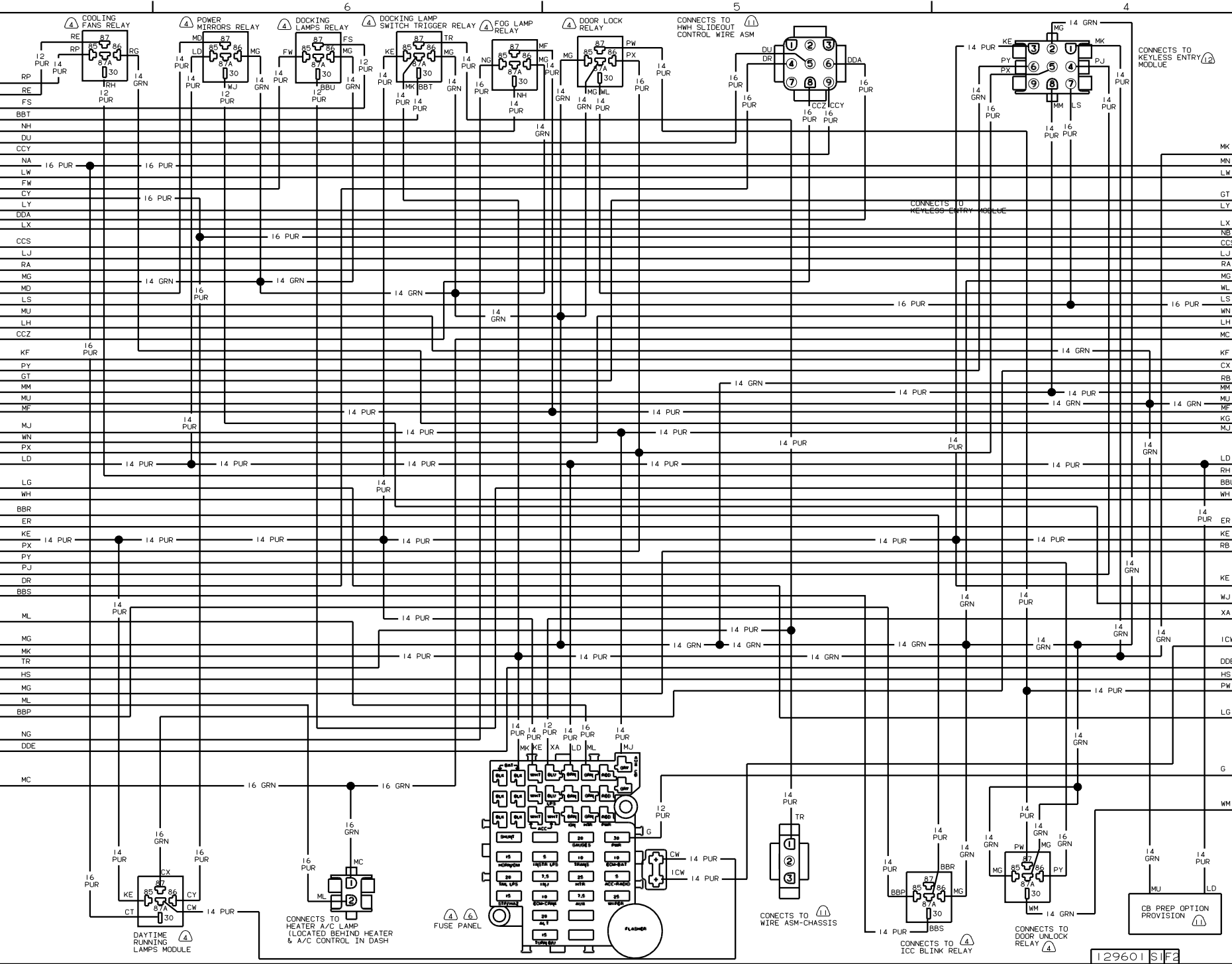

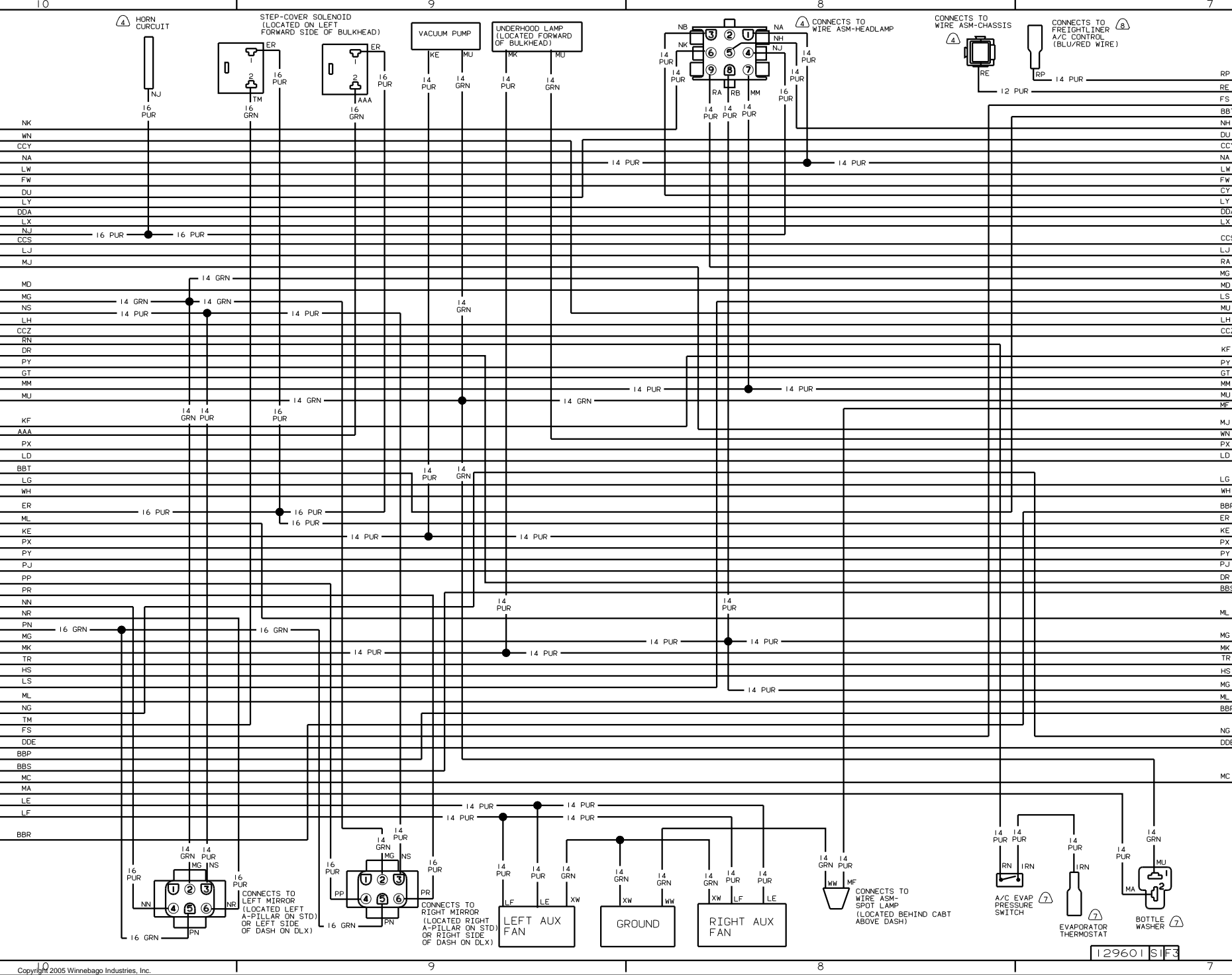

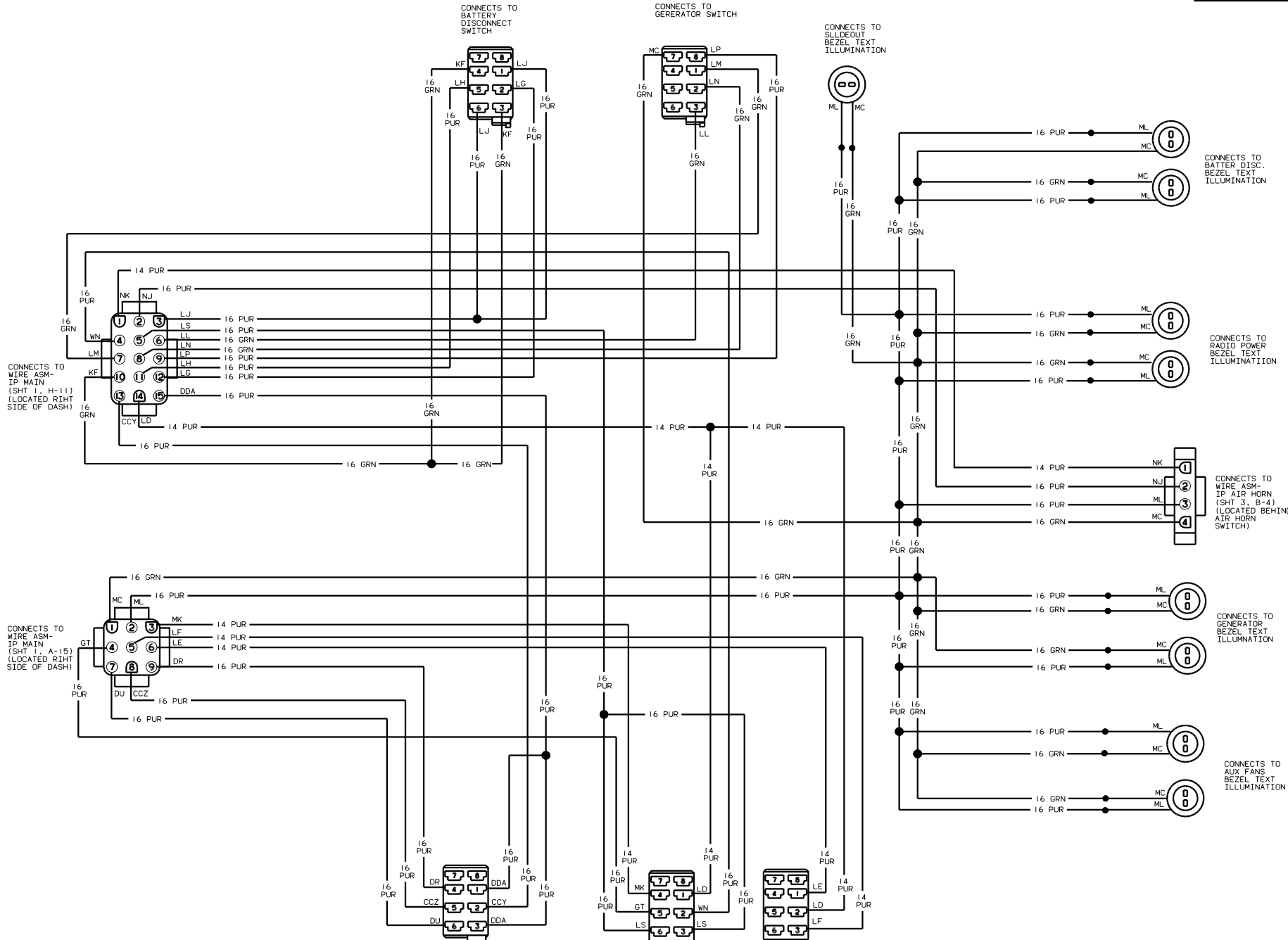

CONNECTS TO WIRE ASM-IP MAIN (SHT 1, H-11) (LOCATED RIHT SIDE OF DASH)

CONNECTS TO WIRE ASM-IP MAIN (SHT 1, A-15) (LOCATED RIHT SIDE OF DASH)

CONNECTS TO BATTERY DISCONNECT SWITCH

CONNECTS TO GENERATOR SWITCH

CONNECTS TO SLIDEOUT BEZEL TEXT ILLUMINATION

CONNECTS TO BATTER DISC. BEZEL TEXT ILLUMINATION

CONNECTS TO RADIO POWER BEZEL TEXT ILLUMINATION

CONNECTS TO WIRE ASM-IP AIR HORN (SHT 3, B-4) (LOCATED BEHIND AIR HORN SWITCH)

CONNECTS TO GENERATOR BEZEL TEXT ILLUMINATION

CONNECTS TO AUX FANS BEZEL TEXT ILLUMINATION

CONNECTS TO SLIDEOUT CONTROL SWITCH

CONNECTS TO RADIO POWER SWITCH

CONNECTS TO AUX FANS SWITCH

WIRING DIAGRAM IP, RIGHT (WIRE ASM 130159)

99 Q-SERIES

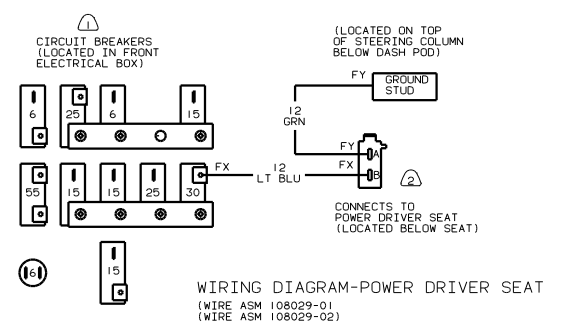
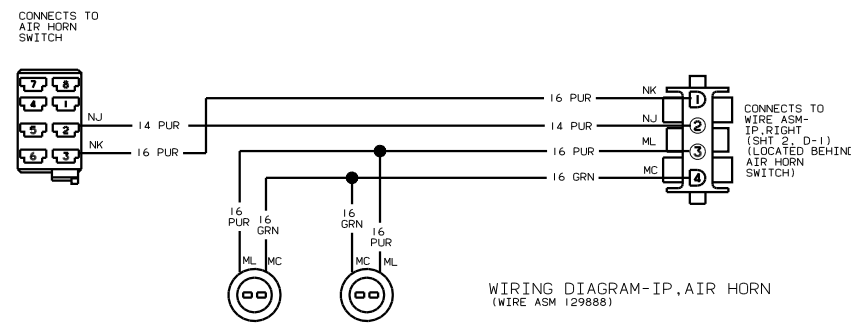
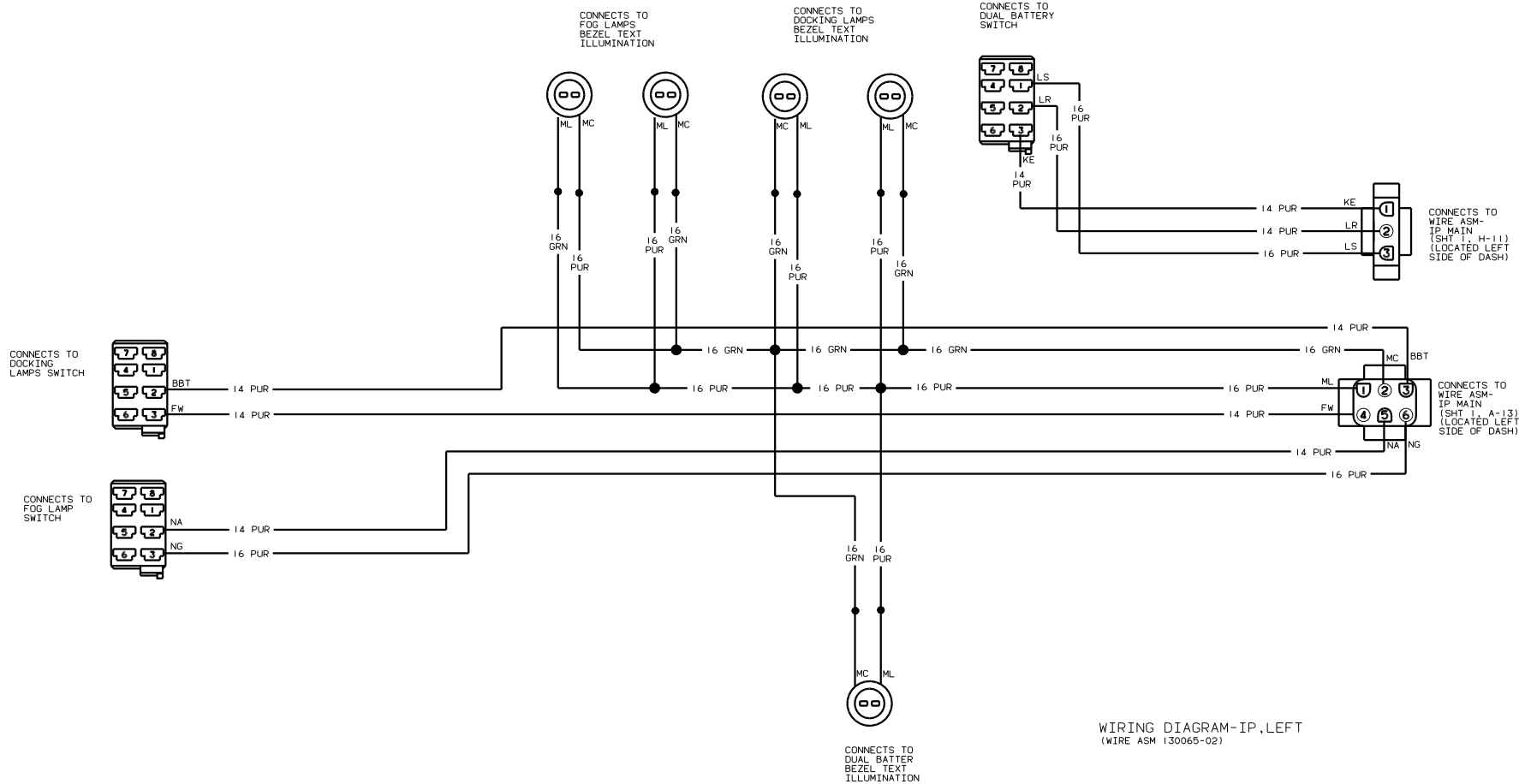

② SEE MANUFACTURER'S DIAGRAM FOR ADDITION INFORMATION.
 ① SEE SHT 1 FOR ADDITIONAL INFORMATION.

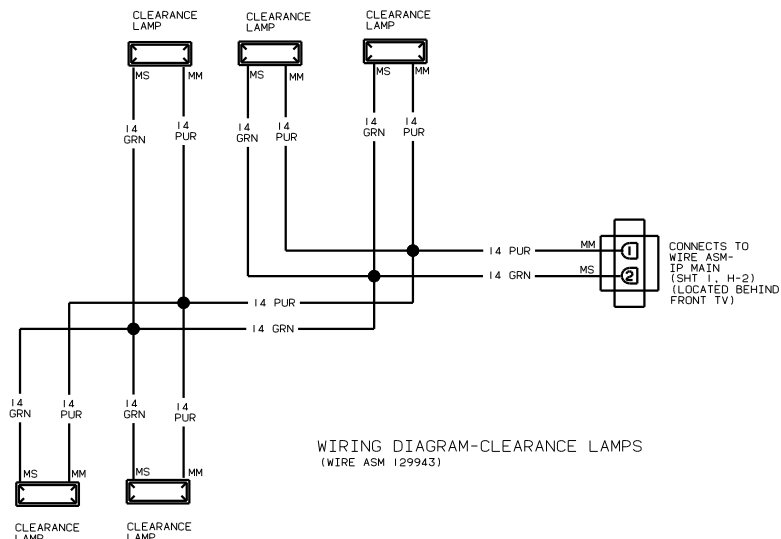
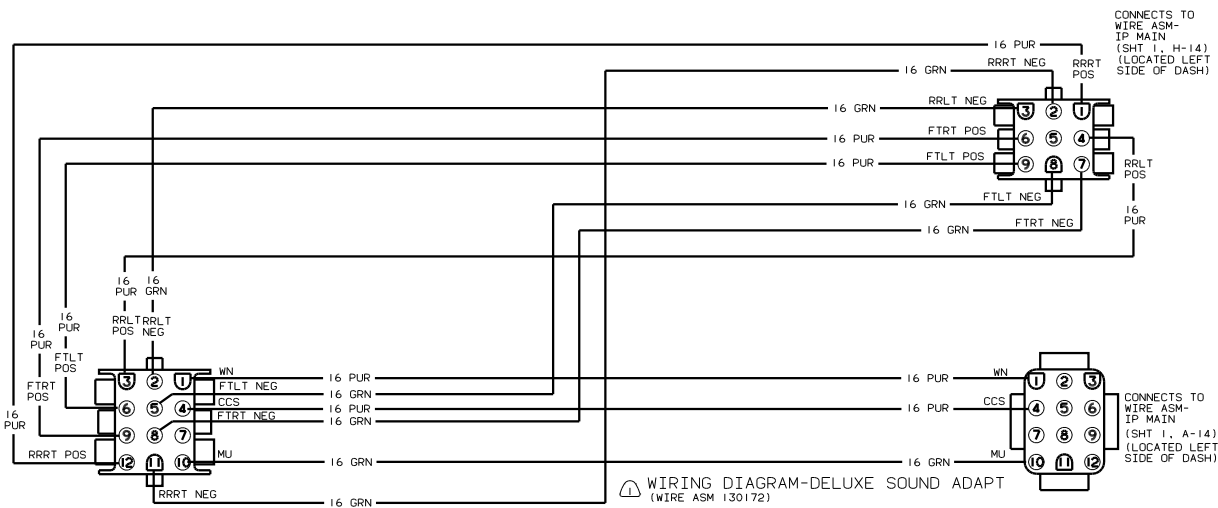

③ SEE SHT 1 FOR ADDITIONAL INFORMATION.
 ② SEE WIRING DIAGRAM-BODY FOR ADDITIONAL INFORMATION.
 ① W/DELUXE SOUND SYSTEM ONLY.

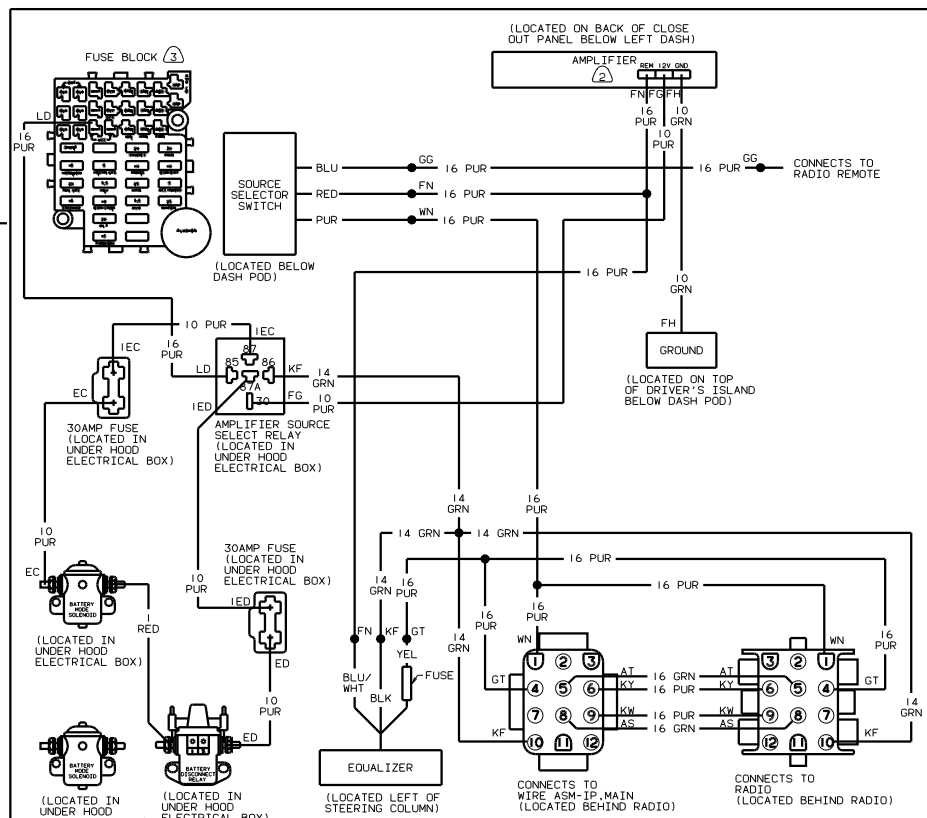

WIRING DIAGRAM-AUTO_FL
(WIRE ASM 124337)

99 0-SERIES
 SHEET 4 OF 5

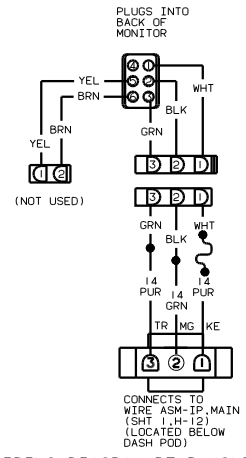

WIRING DIAGRAM-REAR MONITOR, UPPER
(WIRE ASM 96717)

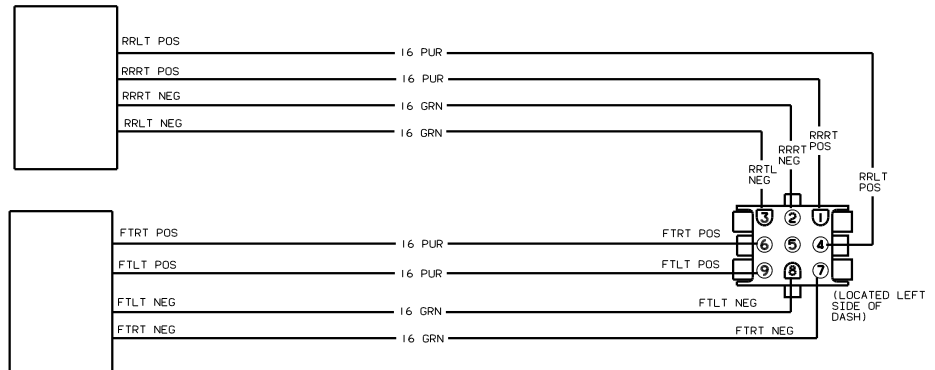

WIRING DIAGRAM-DELUXE SOUND ADAPT
(WIRE ASM 130173)