



**DANGER**

**Danger of electrical shock, burns or death.** Always remove all power sources before attempting any repair, service or diagnostic work. Power can be present from shore power, generator, inverter or battery. All power sources must be disabled and secured before performing any service.



**CAUTION**

If you lack the skills, tools or equipment to perform diagnostic or repair work leave such work to an authorized Winnebago Industries dealer or other qualified shop.

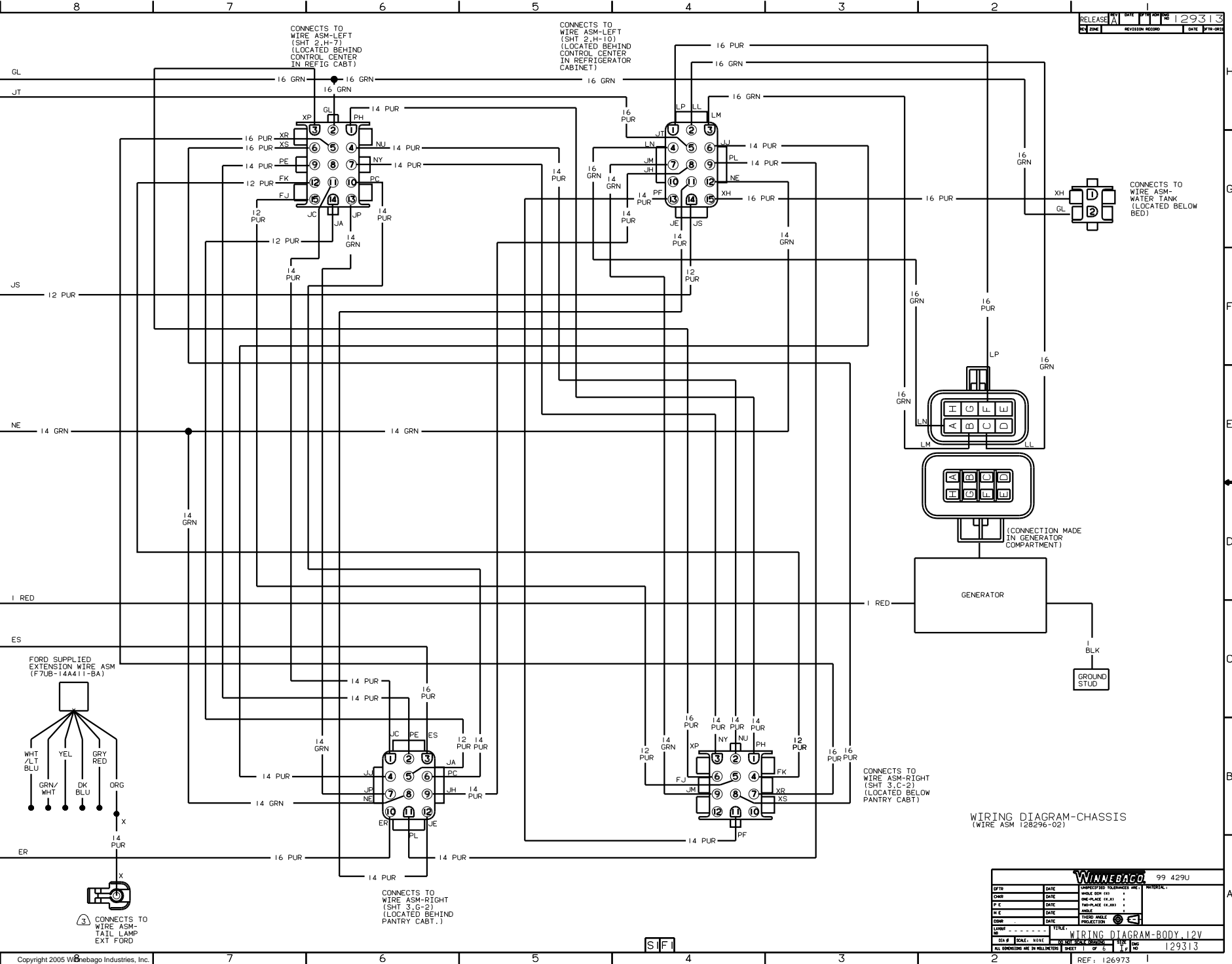

WIRING DIAGRAM-CHASSIS  
 (WIRE ASM 128296-02)

DFTD		DATE	UNAPPROVED TOLERANCES ARE MATERIAL.
CHWD	DATE	MADE FOR (1)	
P.E.	DATE	ONE-PLACE (1,1,1)	
W.E.	DATE	TWO-PLACE (1,1,1)	
CHWD	DATE	MADE	
CHWD	DATE	THIRD MADE	
CHWD	DATE	COLLECTION	
LIGHT	DATE	TITLE	
SCALE	DATE	WIRING DIAGRAM-BODY.12V	
SHEET 1 OF 6		REV. NO.	129313

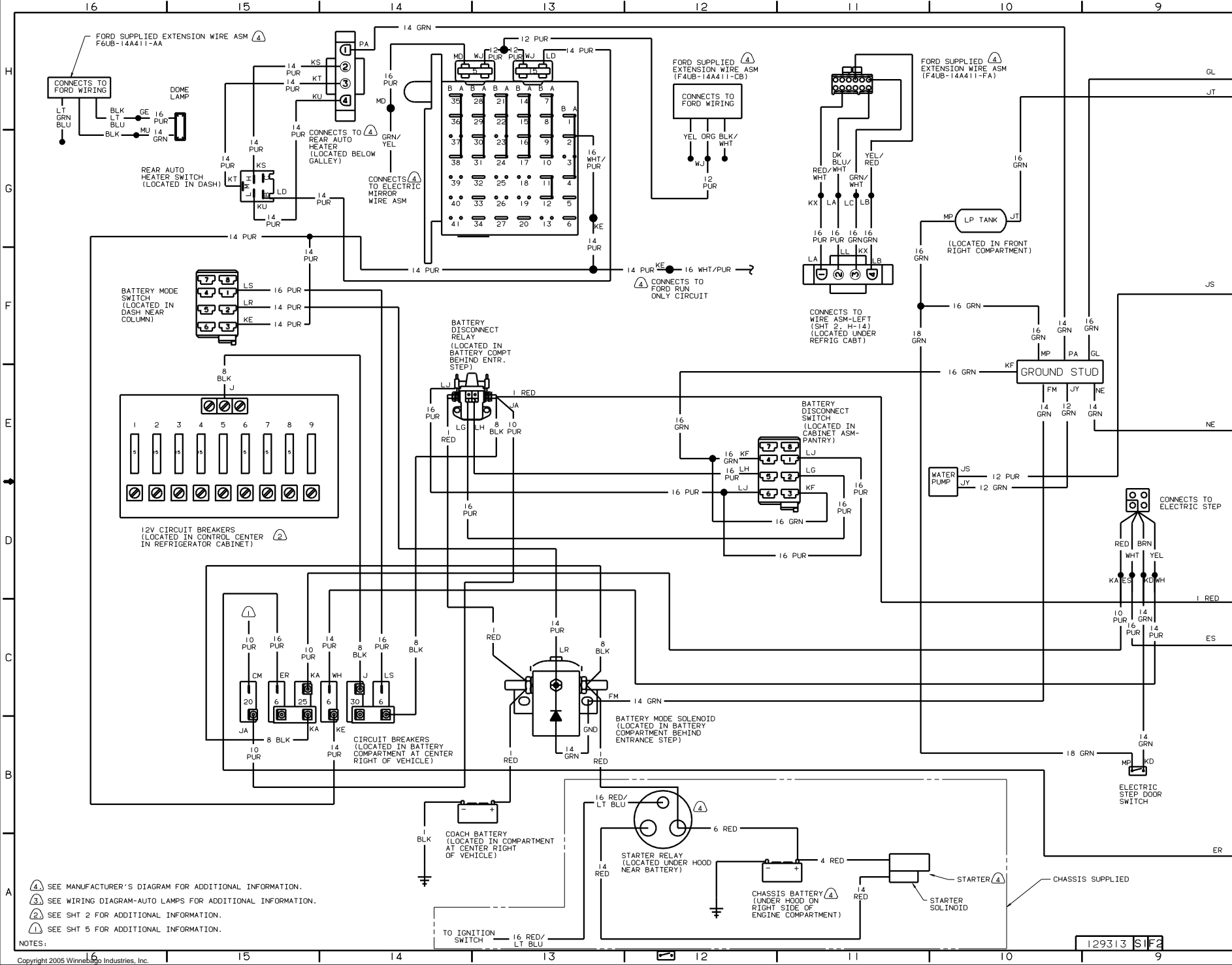

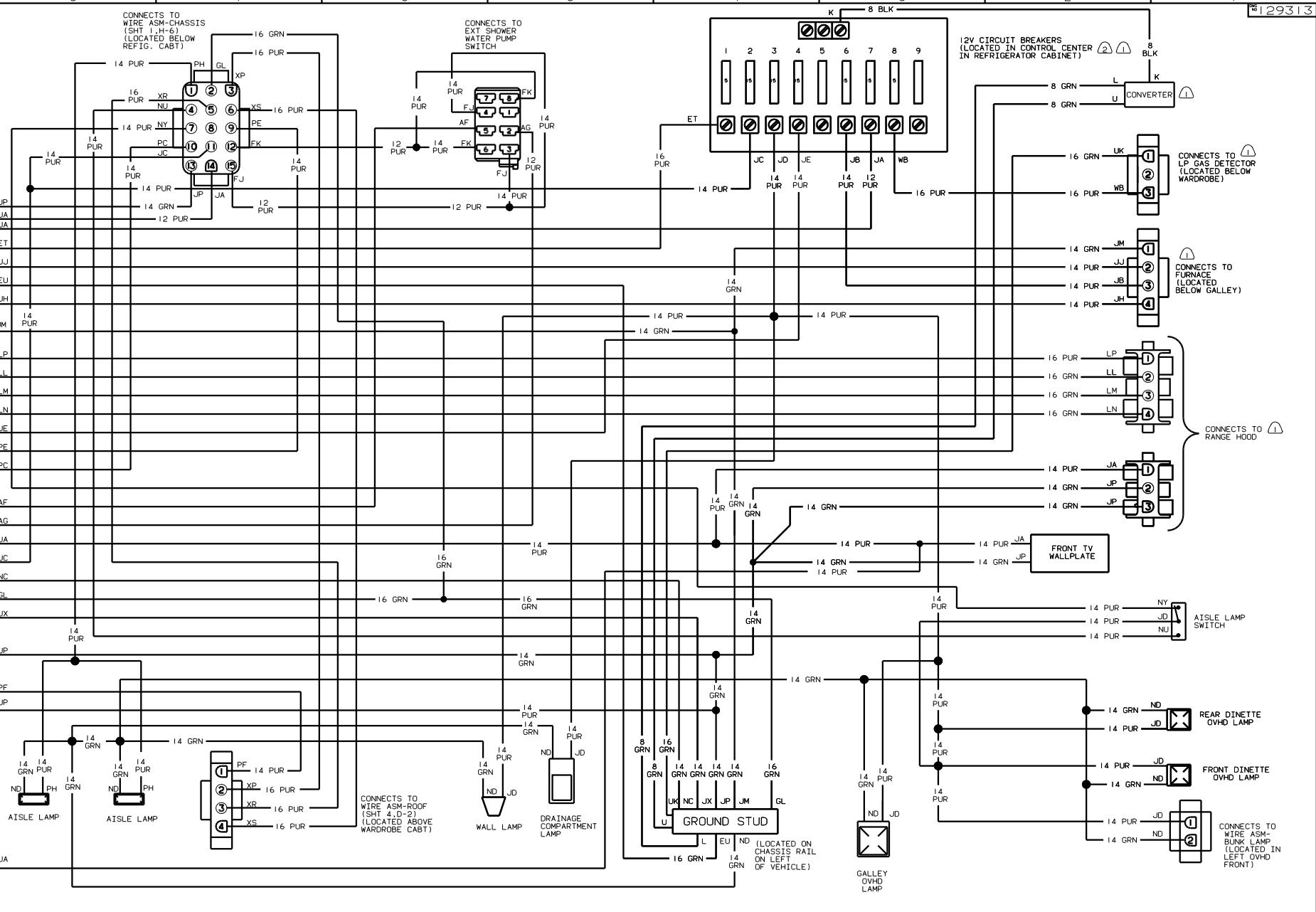

WIRING DIAGRAM-LEFT  
 (WIRE ASM 129335)  
 (FORD CHASSIS)

99 429U

WIRING DIAGRAM-BODY.12V	
DO NOT SCALE DRAWING	DATE
SHEET 2 OF 6	DEC 1 1993

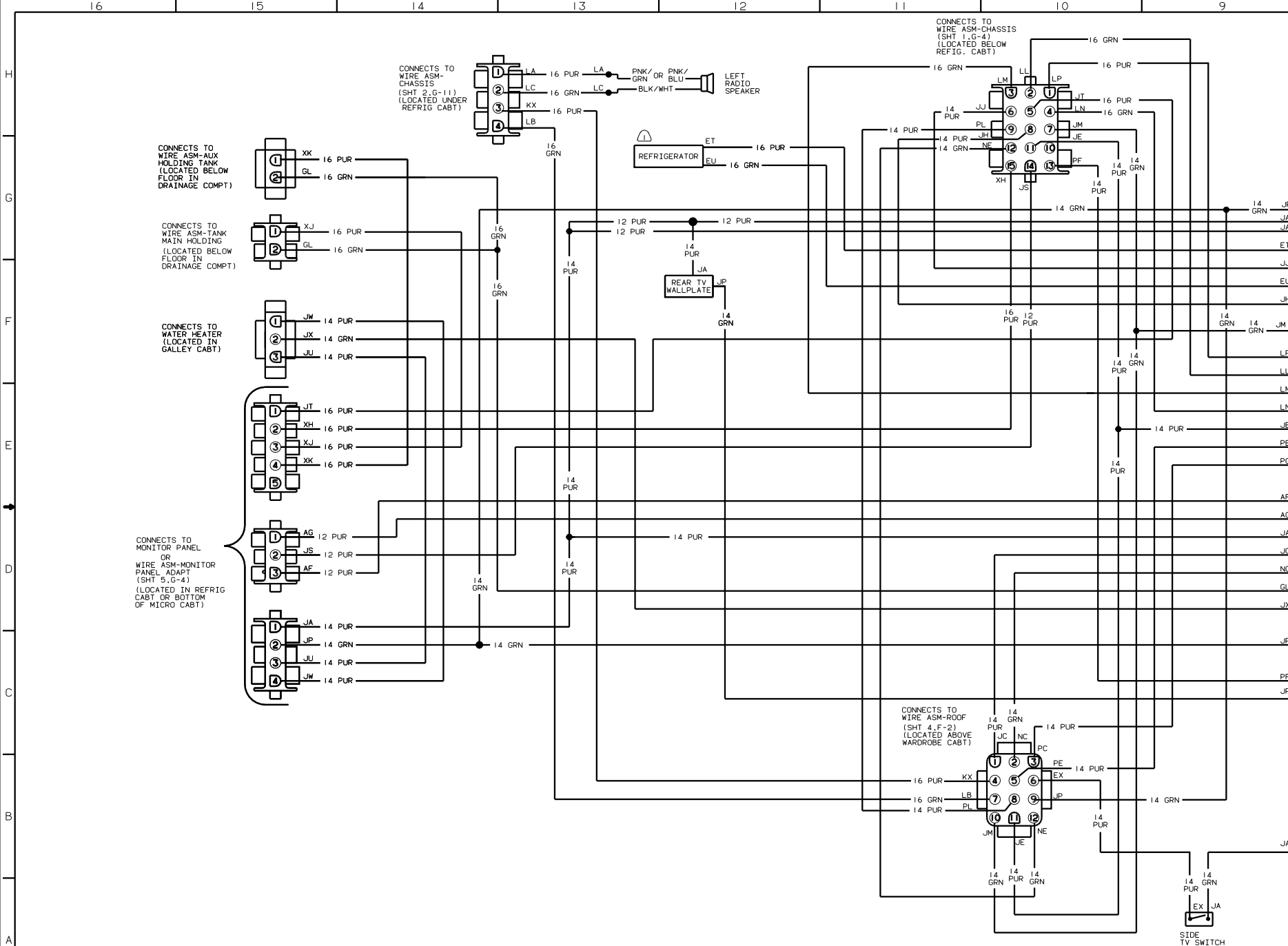

CONNECTS TO WIRE ASM-AUX HOLDING TANK (LOCATED BELOW FLOOR IN DRAINAGE COMPT)

CONNECTS TO WIRE ASM-TANK MAIN HOLDING (LOCATED BELOW FLOOR IN DRAINAGE COMPT)

CONNECTS TO WATER HEATER (LOCATED IN GALLEY CABT)

CONNECTS TO MONITOR PANEL OR WIRE ASM-MONITOR PANEL ADAPT (SHT 5,G-4) (LOCATED IN REFRIG CABT OR BOTTOM OF MICRO CABT)

CONNECTS TO WIRE ASM-CHASSIS (SHT 2,G-11) (LOCATED UNDER REFRIG CABT)

CONNECTS TO WIRE ASM-CHASSIS (SHT 1,G-4) (LOCATED BELOW REFRIG. CABT)

CONNECTS TO WIRE ASM-ROOF (SHT 4,F-2) (LOCATED ABOVE WARDROBE CABT)

② SEE SHT 1 FOR ADDITIONAL INFORMATION  
 ① SEE MANUFACTURER'S DIAGRAM FOR ADDITIONAL INFORMATION.

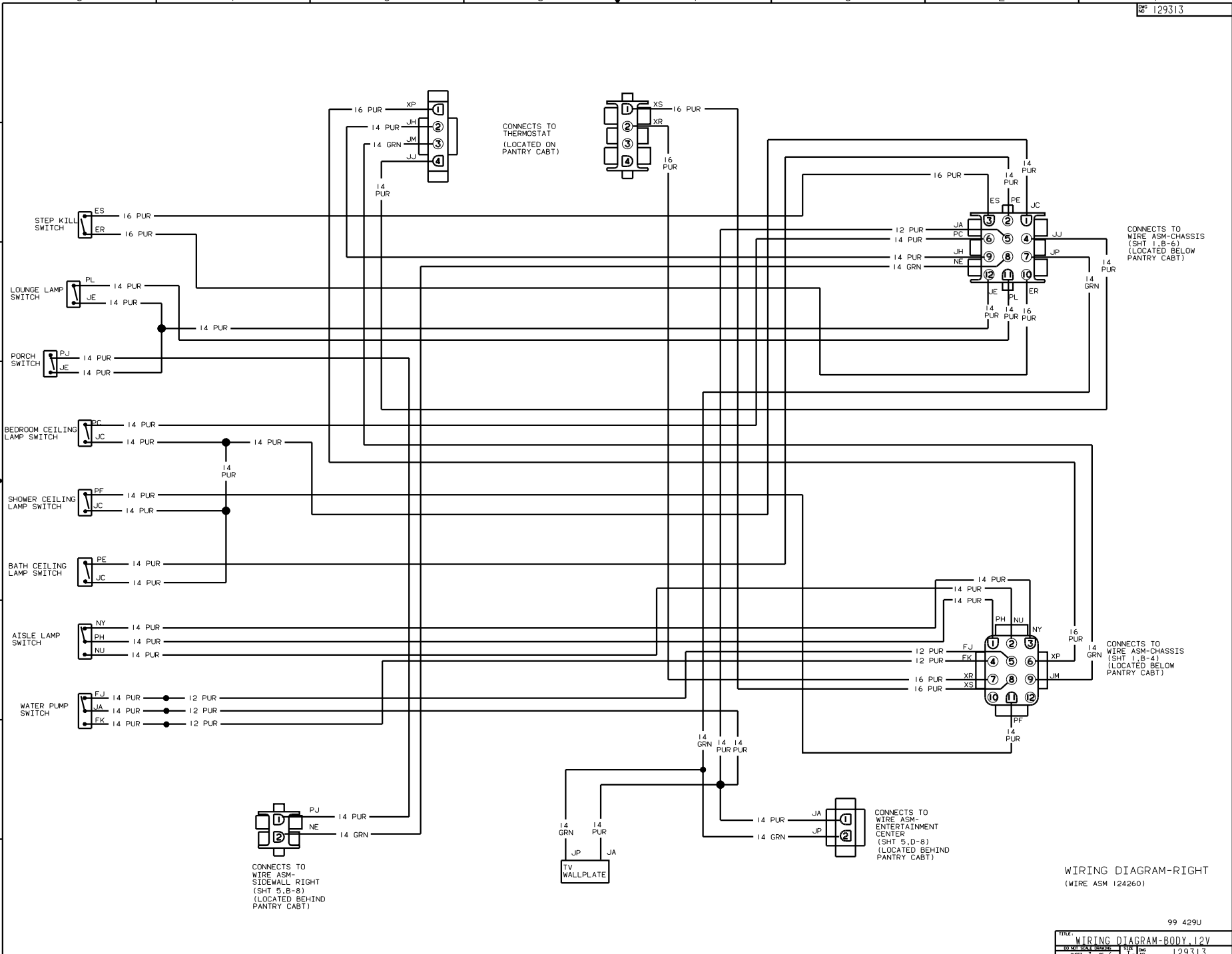

WIRING DIAGRAM-RIGHT  
(WIRE ASM 124260)

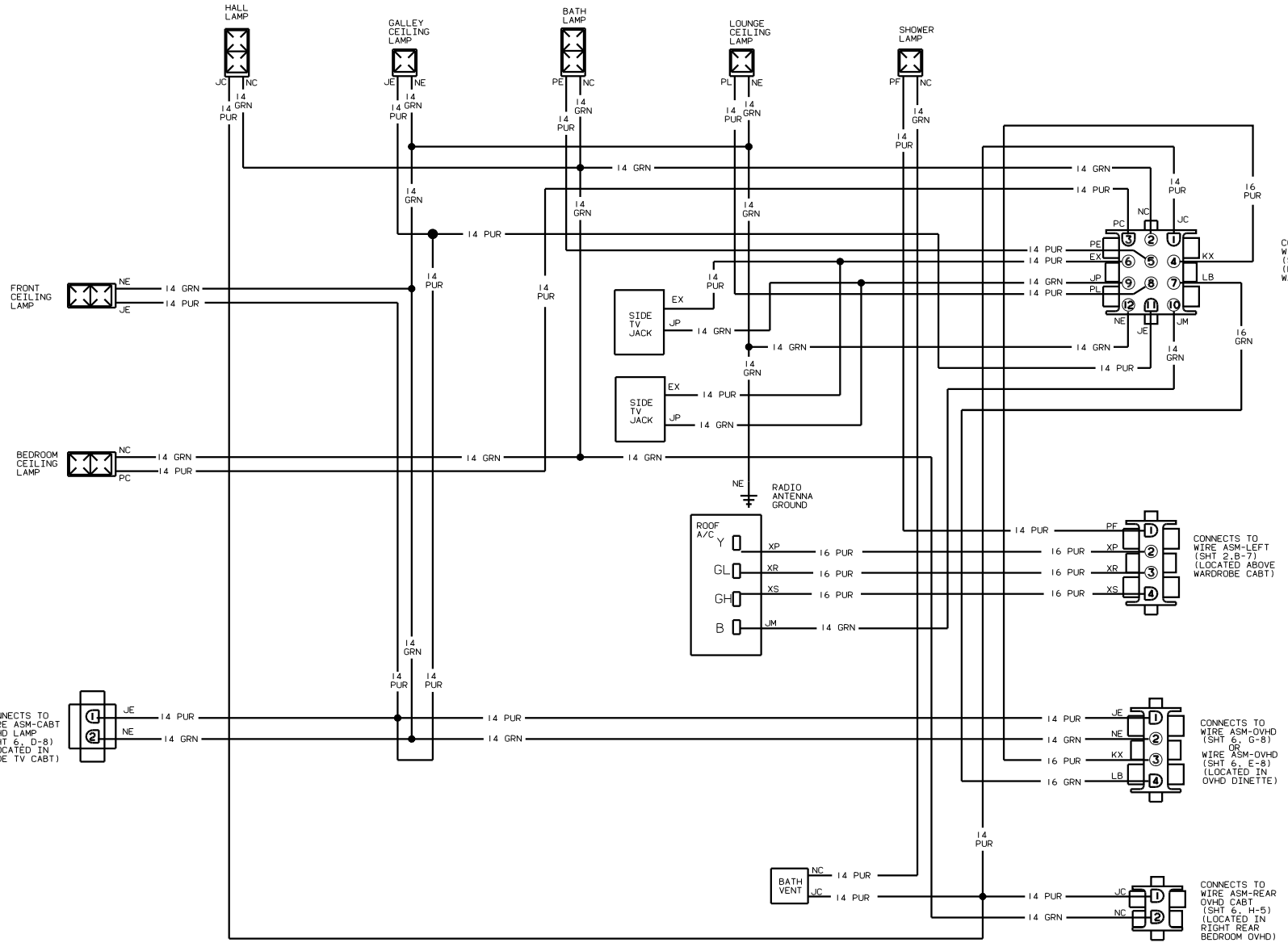

CONNECTS TO WIRE ASM-LEFT (SHT 2, 5-10) (LOCATED ABOVE WARDROBE CABT)

CONNECTS TO WIRE ASM-LEFT (SHT 2, 5-7) (LOCATED ABOVE WARDROBE CABT)

CONNECTS TO WIRE ASM-OVHD (SHT 6, G-8) OR WIRE ASM-OVHD (SHT 6, E-8) (LOCATED IN OVHD DINETTE)

CONNECTS TO WIRE ASM-REAR OVHD CABT (SHT 6, H-5) (LOCATED IN RIGHT REAR BEDROOM OVHD)

CONNECTS TO WIRE ASM-CABT OVHD LAMP (SHT 5, D-8) (LOCATED IN SIDE TV CABT)

WIRING DIAGRAM-ROOF (WIRE ASM 129311)

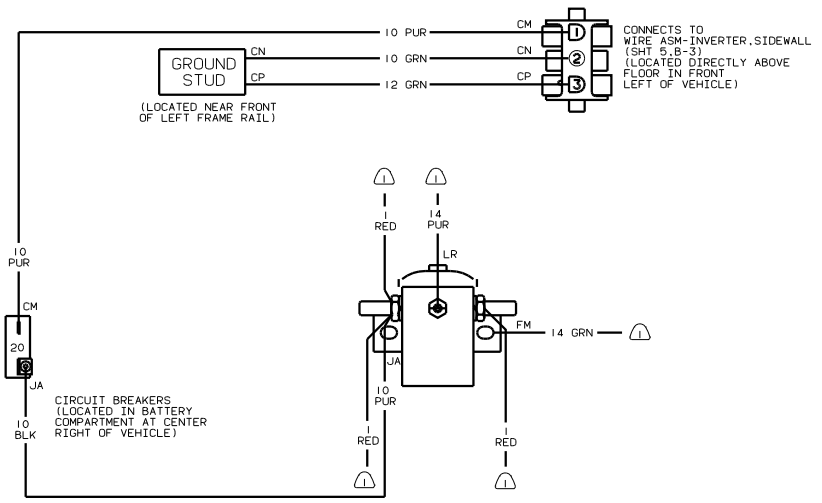

WIRING DIAGRAM-INVERTER, CHASSIS (WIRE ASM 110606-04) (WITH INVERTER)

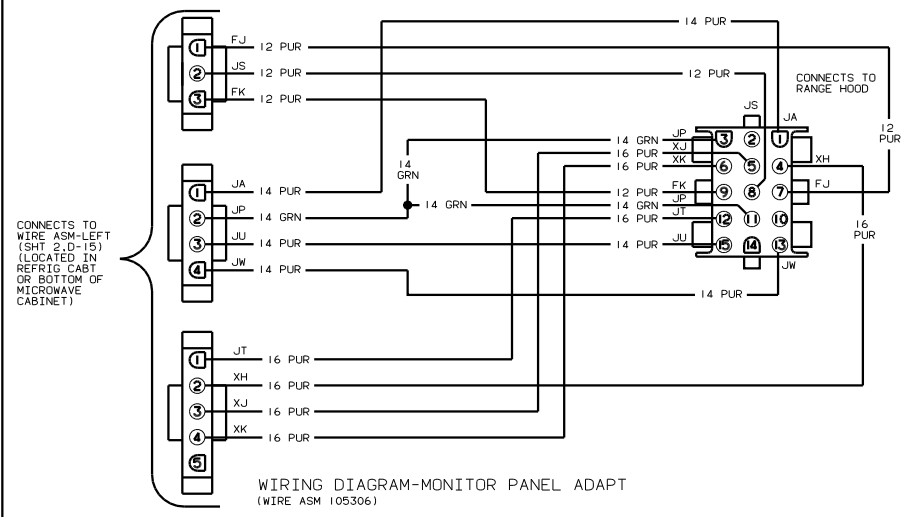

WIRING DIAGRAM-MONITOR PANEL ADAPT (WIRE ASM 105306)

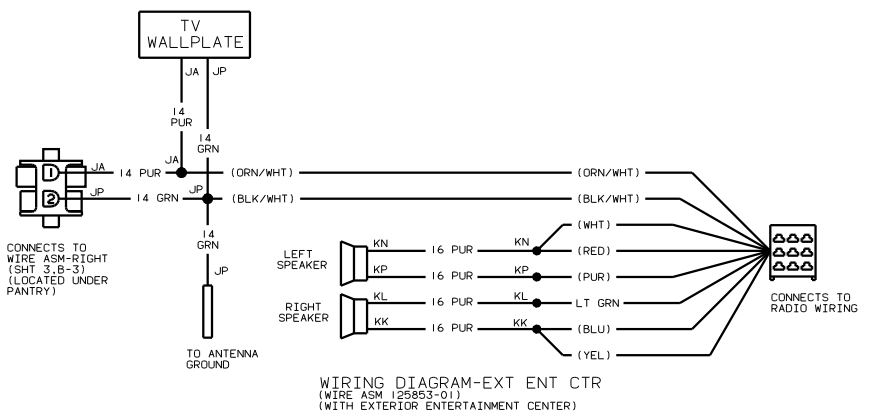

WIRING DIAGRAM-EXT ENT CTR (WIRE ASM 125853-01) (WITH EXTERIOR ENTERTAINMENT CENTER)

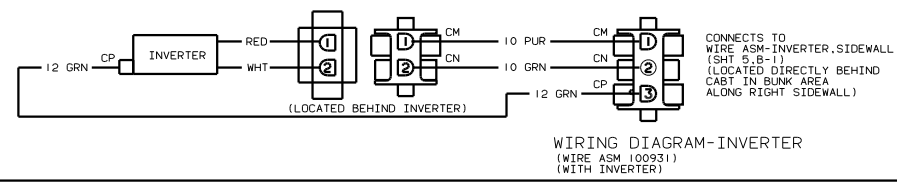

WIRING DIAGRAM-INVERTER (WIRE ASM 100931) (WITH INVERTER)

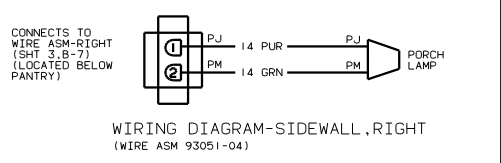

WIRING DIAGRAM-SIDEWALL, RIGHT (WIRE ASM 93051-04)

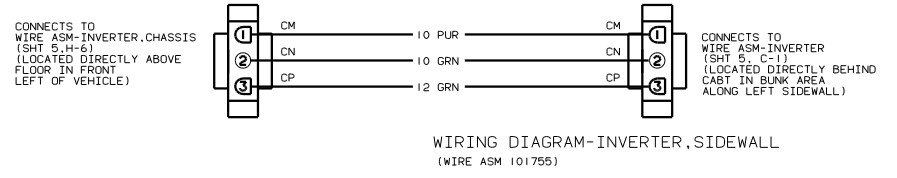

WIRING DIAGRAM-INVERTER, SIDEWALL (WIRE ASM 101755)

NOTES: 1) SEE SHT 1 FOR ADDITIONAL INFORMATION.



