



DANGER

Danger of electrical shock, burns or death. Always remove all power sources before attempting any repair, service or diagnostic work. Power can be present from shore power, generator, inverter or battery. All power sources must be disabled and secured before performing any service.



CAUTION

If you lack the skills, tools or equipment to perform diagnostic or repair work leave such work to an authorized Winnebago Industries dealer or other qualified shop.

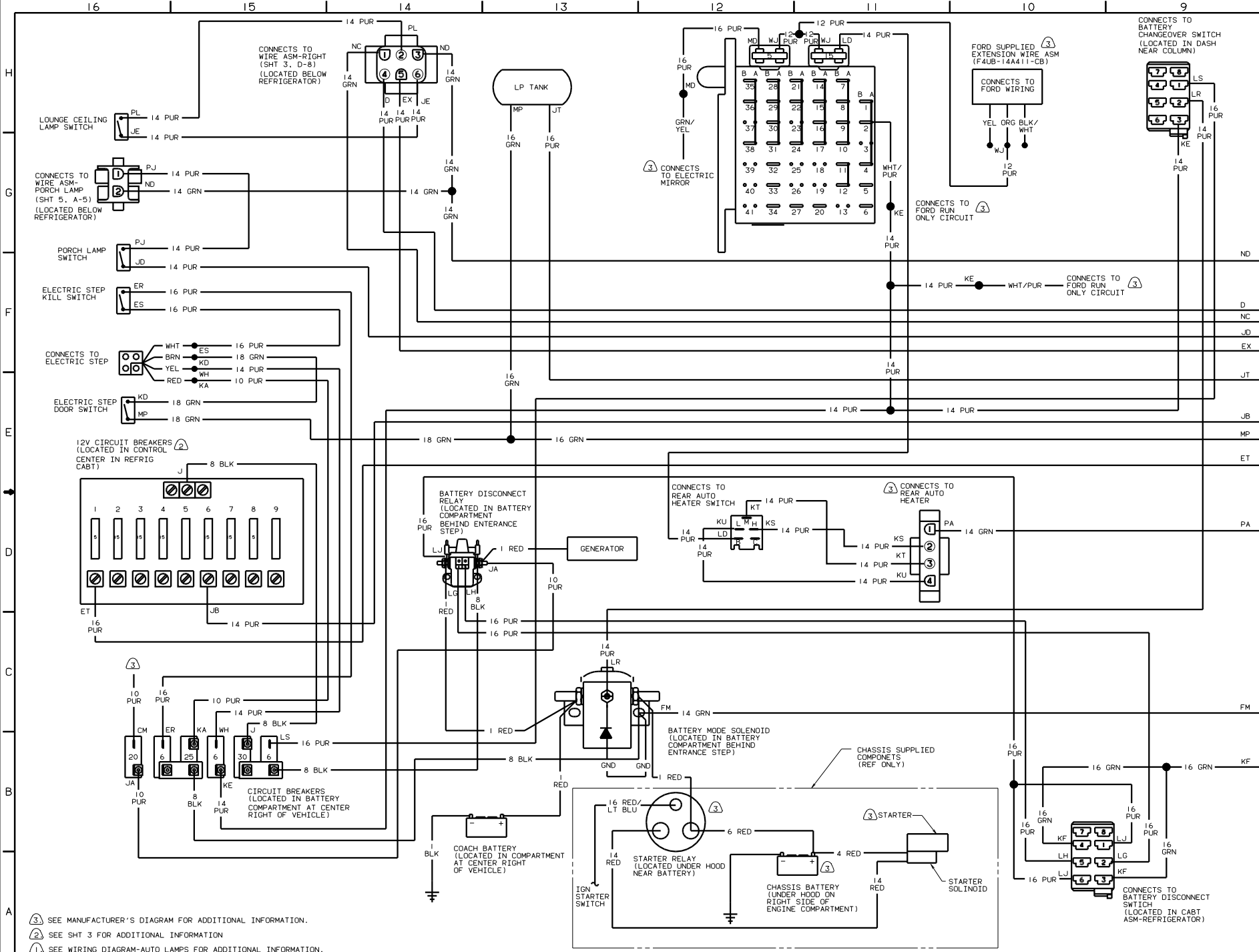

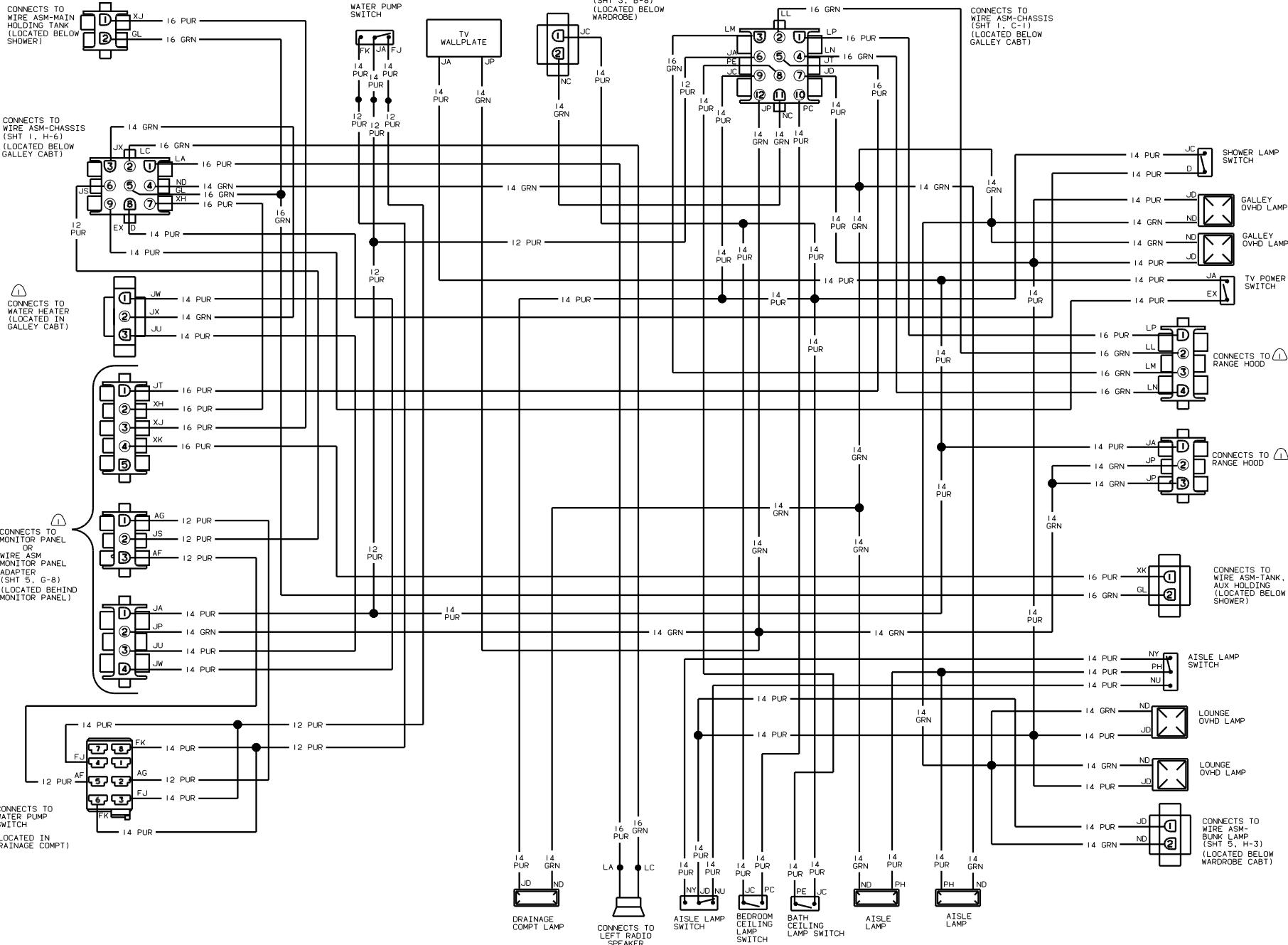

CONNECTS TO WIRE ASM-MAIN HOLDING TANK (LOCATED BELOW SHOWER)

CONNECTS TO WIRE ASM-CHASSIS (SHT 1, H-6) (LOCATED BELOW GALLEY CABT)

CONNECTS TO WATER HEATER (LOCATED IN GALLEY CABT)

CONNECTS TO MONITOR PANEL OR WIRE ASM MONITOR PANEL ADAPTER (SHT 5, G-8) (LOCATED BEHIND MONITOR PANEL)

CONNECTS TO WATER PUMP SWITCH (LOCATED IN DRAINAGE COMPT)

WATER PUMP SWITCH

TV WALLPLATE

CONNECTS TO WIRE ASM-SIDEWALL (SHT 3, B-8) (LOCATED BELOW WARDROBE)

CONNECTS TO WIRE ASM-CHASSIS (SHT 1, C-1) (LOCATED BELOW GALLEY CABT)

CONNECTS TO RANGE HOOD

CONNECTS TO RANGE HOOD

CONNECTS TO WIRE ASM-TANK, AUX HOLDING (LOCATED BELOW SHOWER)

CONNECTS TO WIRE ASM-BUNK LAMP (SHT 5, H-3) (LOCATED BELOW WARDROBE CABT)

SEE MANUFACTURER'S DIAGRAM FOR ADDITIONAL INFORMATION.

WIRING DIAGRAM-LEFT
(WIRE ASM 129232)

99 431A

TITLE: WIRING DIAGRAM-BODY 12V	
NO. OF SHEETS: 5	SHEET NO. 2
DATE: 1/6	REV: 1
129229	

12V CIRCUIT BREAKER
(LOCATED IN
CONTROL CENTER
IN REFRIG
CABT)

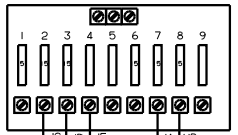

TV
WALLPLATE

CONNECTS TO
WIRE ASM-CHASSIS
(SHT 1, A-4)
(LOCATED BELOW
REFRIGERATOR)

CONNECTS TO
WIRE ASM-
EXT ENT CTR
(SHT 5, D-8)
(LOCATED BELOW
REFRIGERATOR)

CONNECTS TO
THERMOSTAT

CONNECTS TO
THERMOSTAT

CONNECTS TO
LP DETECTOR

CONNECTS TO
WIRE ASM-
BEDROOM OR
WIRE ASM-
SIDEWALL
(W/TWIN & BUNK BEDS)
(SHT 3, B-8)
(LOCATED BELOW
WARDROBE CABT)

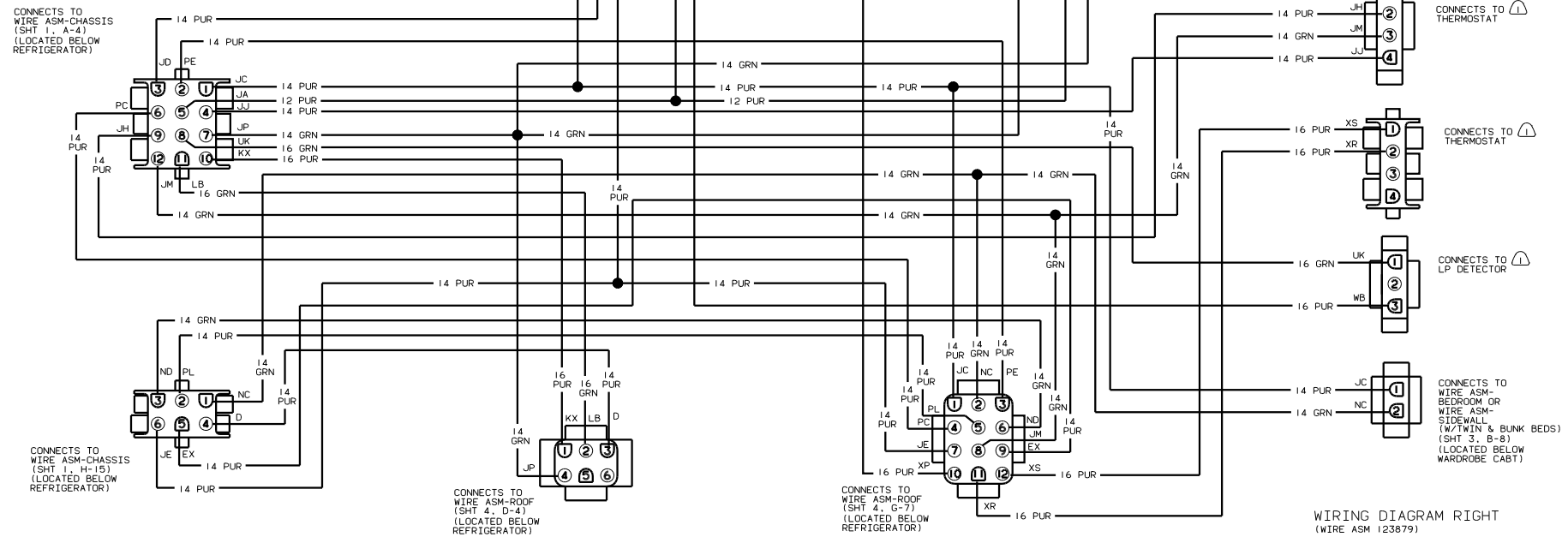

WIRING DIAGRAM RIGHT
(WIRE ASM 123879)

CONNECTS TO
WIRE ASM-CHASSIS
(SHT 1, H-15)
(LOCATED BELOW
REFRIGERATOR)

CONNECTS TO
WIRE ASM-ROOF
(SHT 4, D-4)
(LOCATED BELOW
REFRIGERATOR)

CONNECTS TO
WIRE ASM-ROOF
(SHT 4, G-7)
(LOCATED BELOW
REFRIGERATOR)

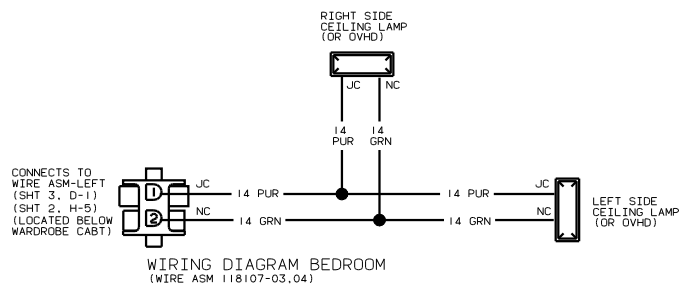

WIRING DIAGRAM BEDROOM
(WIRE ASM 118107-03.04)

CONNECTS TO
WIRE ASM-LEFT
(SHT 3, D-1)
(SHT 2, H-5)
(LOCATED BELOW
WARDROBE CABT)

LEFT SIDE
CEILING LAMP
(OR OVHD)

- SEE SHT 1 FOR ADDITIONAL INFORMATION.
- SEE MANUFACTURER'S DIAGRAM FOR ADDITIONAL INFORMATION.

NOTES:

CONNECTS TO WIRE ASM-RIGHT (SHT 3, D-3) (LOCATED BELOW REFRIGERATOR)

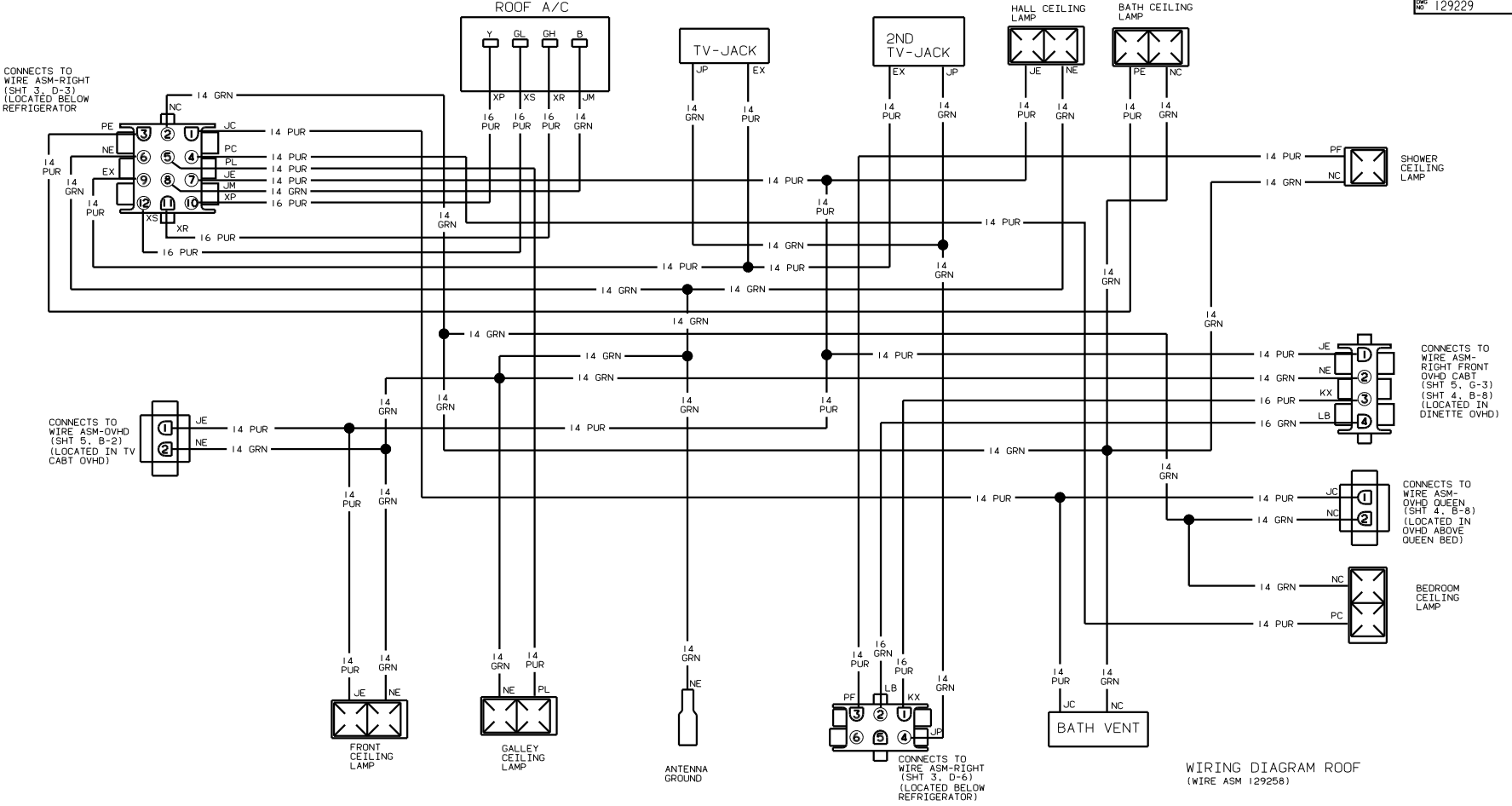

CONNECTS TO WIRE ASM-OVHD (SHT 5, B-2) (LOCATED IN TV CABT OVHD)

CONNECTS TO WIRE ASM-RIGHT FRONT OVHD CABT (SHT 5, G-3) (SHT 4, B-8) (LOCATED IN DINETTE OVHD)

CONNECTS TO WIRE ASM-OVHD QUEEN (SHT 4, B-8) (LOCATED IN OVHD ABOVE QUEEN BED)

CONNECTS TO WIRE ASM-RIGHT (SHT 3, D-6) (LOCATED BELOW REFRIGERATOR)

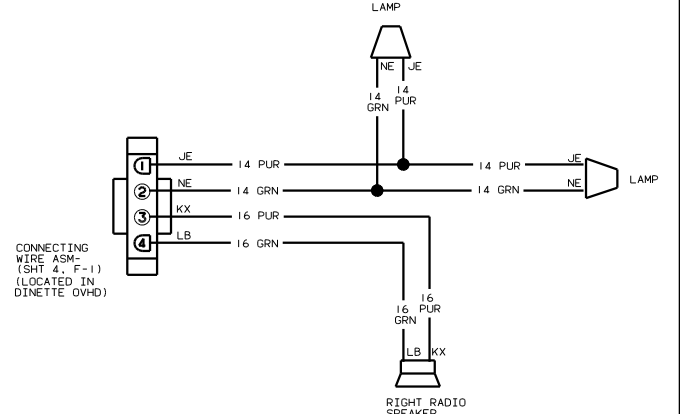

NOTES: 1) IC2 CABT-OVHD W/O TV STORAGE.

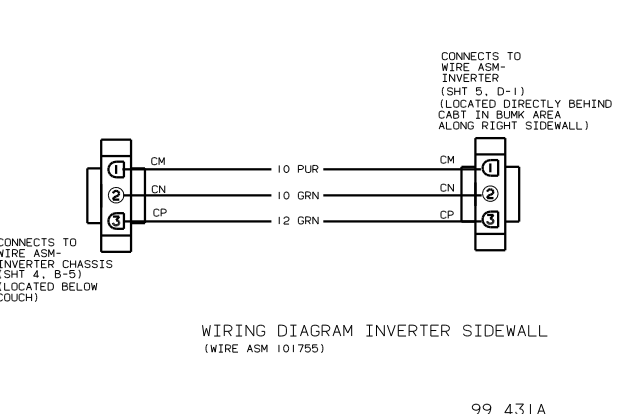
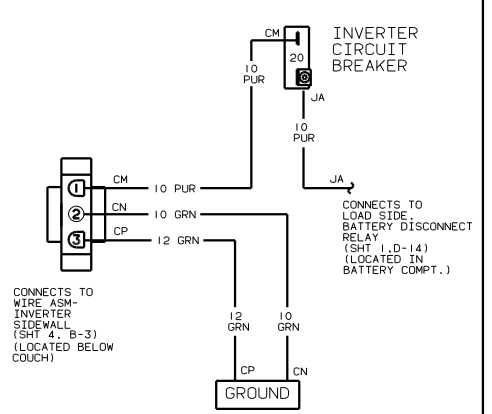

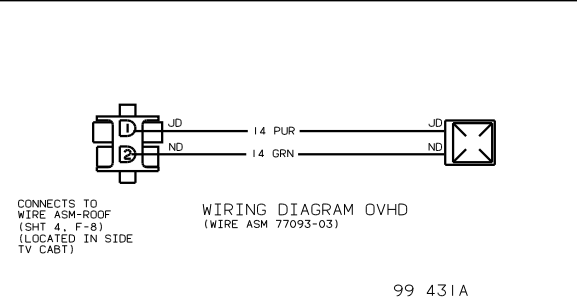
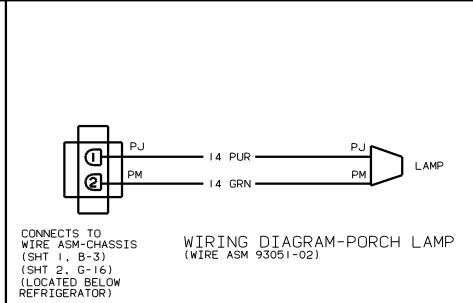
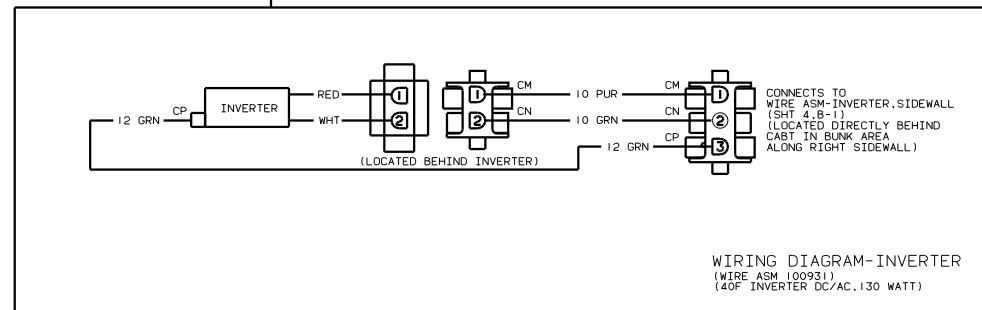
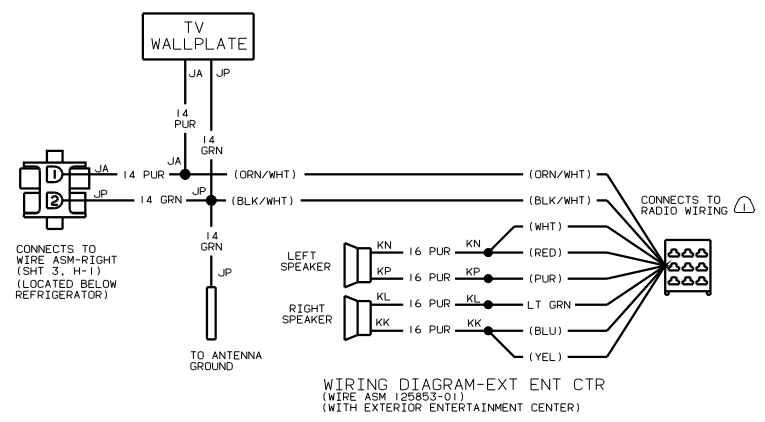
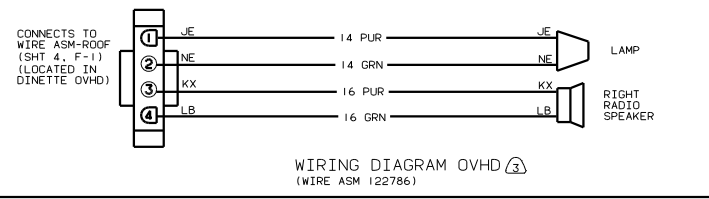
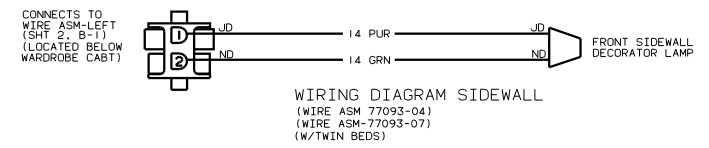
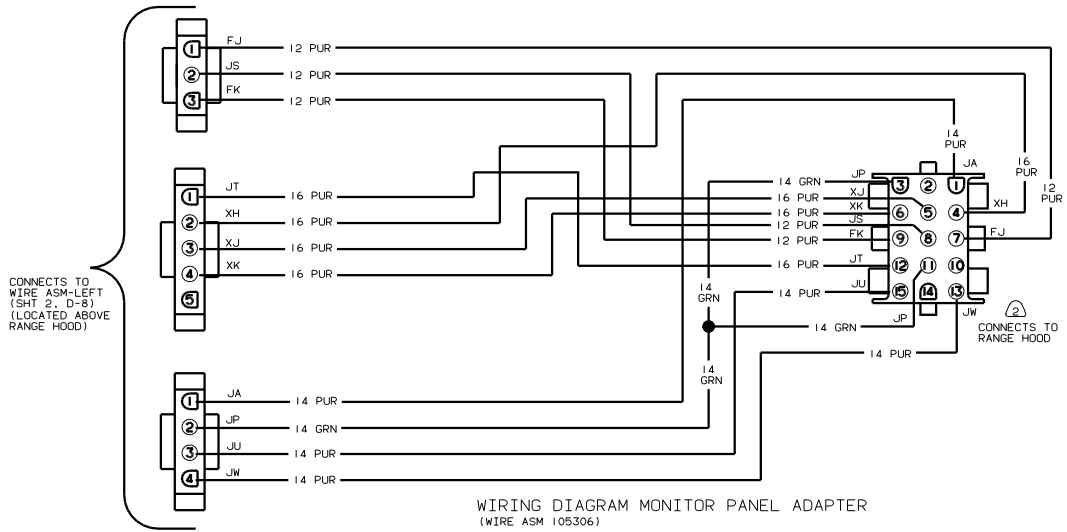

- (3) IC1 CABT-OVHD W/TV STORAGE.
- (2) SEE MANUFACTURER'S DIAGRAM FOR ADDITIONAL INFORMATION.
- (1) SEE WIRING DIAGRAM-AUTO FOR ADDITIONAL INFORMATION.

99 431A