

DWG NO	UNIT	
126391-01	G34WA	G
126391-02	F34WA	F

RELEASE BY DATE BY NO 126391  
 REVISION RECORD DATE BY NO

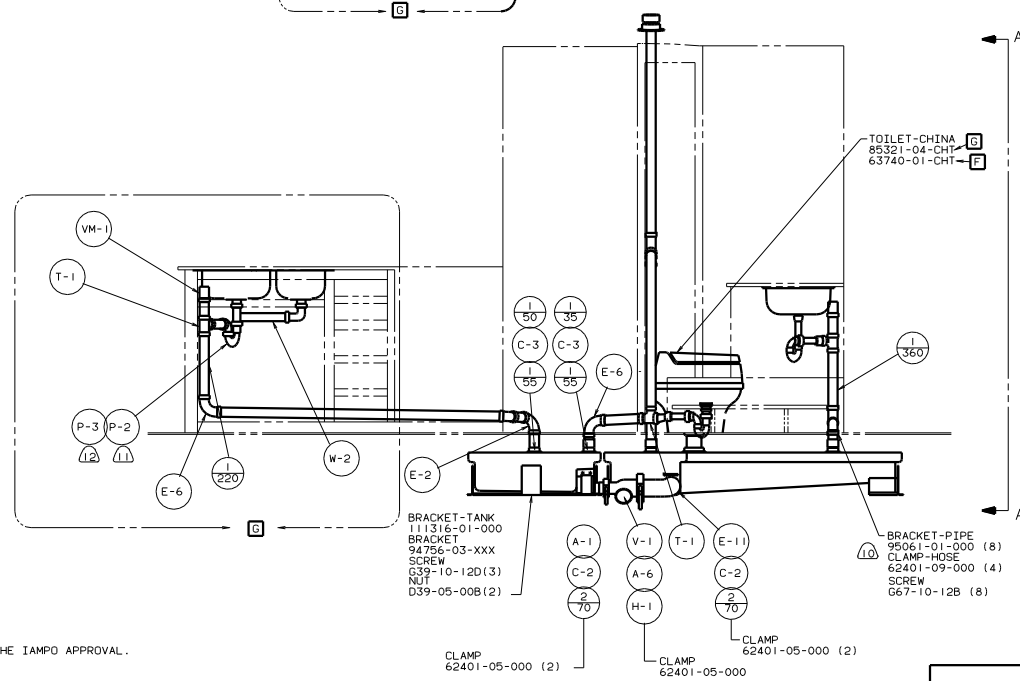
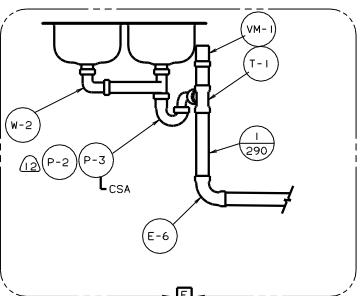
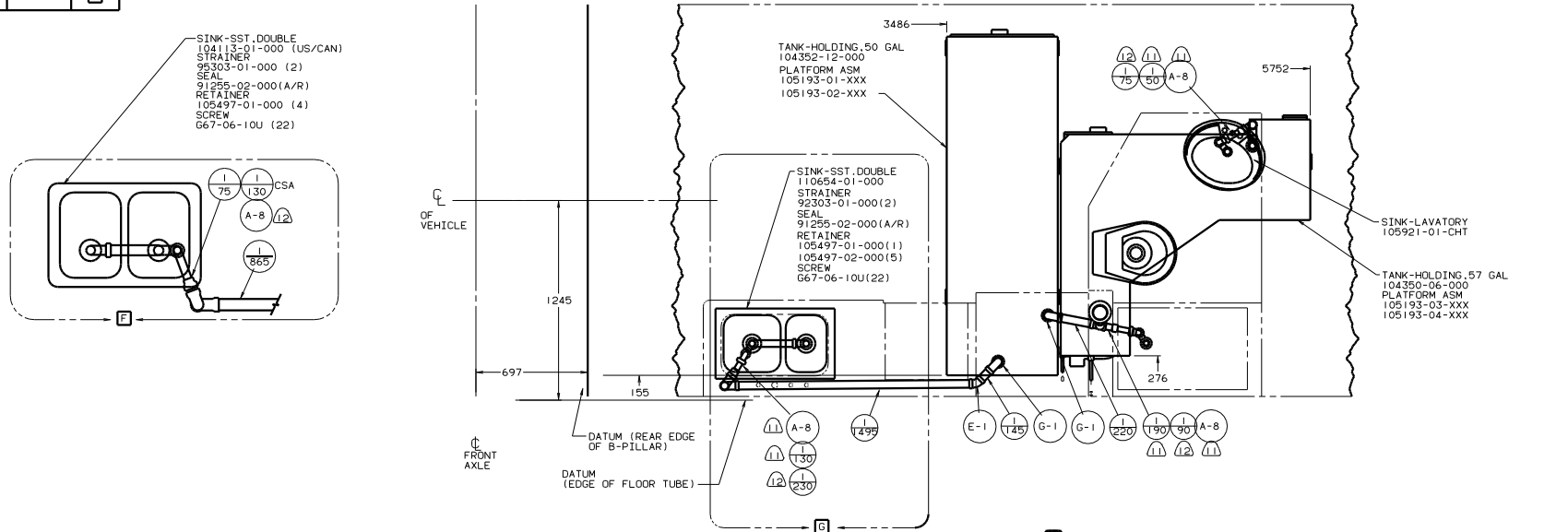

- ⑫ CSA ONLY.
- ⑪ US ONLY.
- ⑩ SECURE VENT TUBES TO FLOOR.
- ⑨ VENT PIPE MUST PROJECT 51 MM MIN AND 63.5 MM MAX ABOVE ROOF FOR PROPER FIT AND FUNCTION.
- 8. SEE DWG 61607-01-000 FOR INSTL OF GROMMETS.
- 7. SEAL ALL AROUND SHOWER WITH SILICONE.
- 6. FOR CAN UNITS EACH HOLDING TANK SHALL HAVE A CSA APPROVAL STAMPED NEAR THE TAMPO APPROVAL.
- 5. EXPOSED PIPE ABOVE ROOF TO BE PAINTED 37163-01-000.
- 4. ALL EXTERIOR OPENINGS AROUND PIPE TO BE SEALED WITH 110744-01-000.
- 3. ALL PIPE AND FITTINGS TO BE ASSEMBLED WITH SOLVENT 4020-01-000.
- 2. SLOPE OF TRAP ARM MUST BE 6 PER 305.
- 1. SLOPE OF HORIZONTAL PIPING TO BE 6 PER 305 MIN.

FOR DRAINAGE CALLOUTS SEE DWG NO. 116229-01-000

		98 F&G34WA
OF TR	DATE	UNDESIGNED TOLERANCES ARE:
CHP	DATE	WHOLE DIM (1)
PIE	DATE	ONE-PLACE (16.41)
D/E	DATE	TWO-PLACE (16.48)
DATE	DATE	MILL
COMP	DATE	THRU WHOLE PRODUCTION
LAYOUT	G34WA	TITLE
SCALE	NOTE	SCALE
ALL DIMENSIONS ARE IN MILLIMETERS	SHEET 1 OF 2	DWG NO
		126391

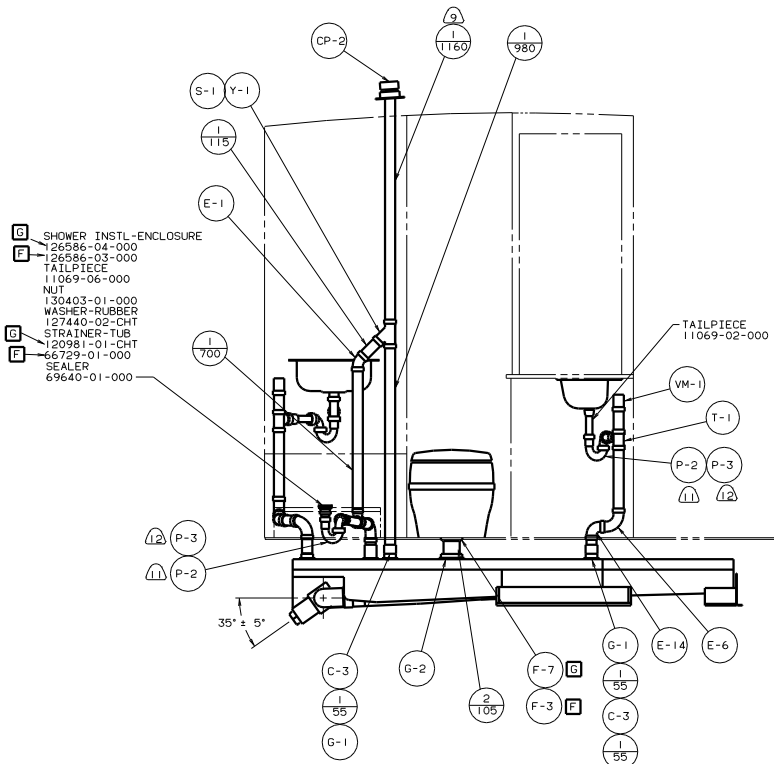

VIEW A-A

DWG NO	UNIT	---
126582-01	G34WA	<b>G</b>
126582-02	F34WA	<b>F</b>

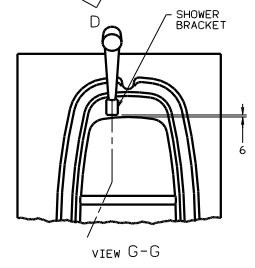
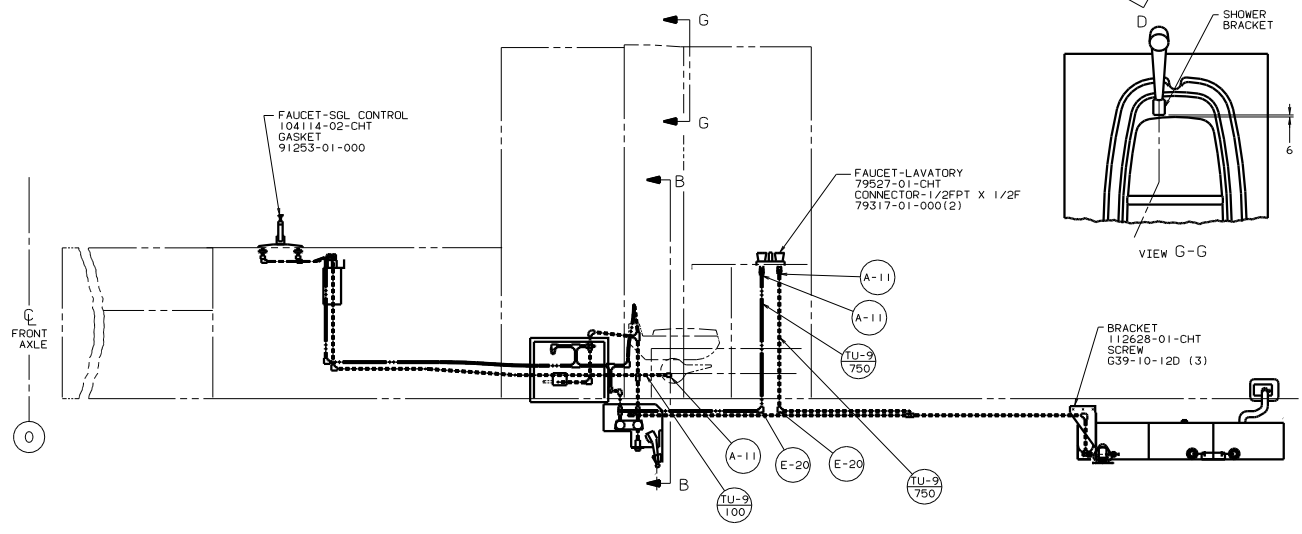
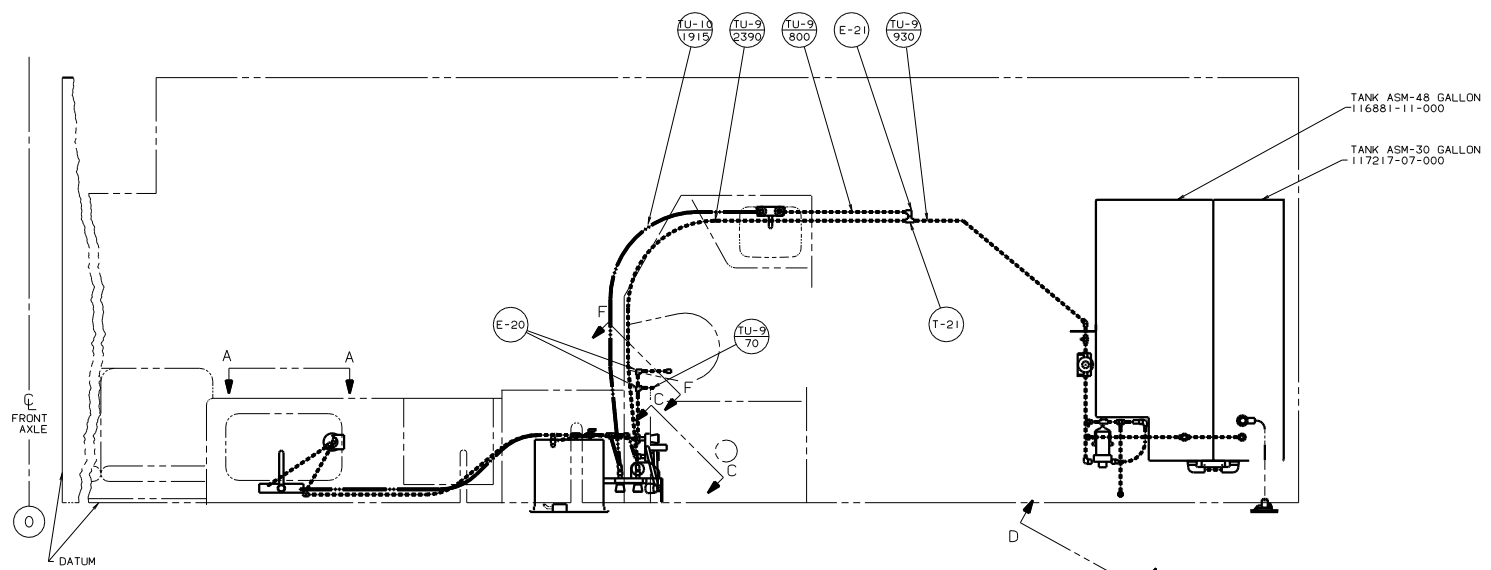

- ① PLASTIC FITTINGS TO BE SEALED WITH SEALANT 84456-01-000.
- 2. TUBING TO BE INSTALLED WITH SUFFICIENT SLOPE TO PROVIDE DRAINAGE TO NEAREST VALVE.
- 3. ALL TUBING TO BE SECURED AT 1200 INTERVALS MAX WITH CLIP 91951-01-000 AND SCREW G13-06-16U.
- ④ LOCATE CUTOUT TO SUPPORT WATER HEATER.
- ⑤ CLAMP MUST BE ON BARBS.
- ⑥ BRACKET FLANGE TO BE MOUNTED FLUSH WITH TOP OF CHASSIS RISERS.

LEGEND	
HOT	-----
COLD	-----

X-X FOR WATER CALLOUTS SEE DWG NO. 116230-01-000

WINNEBAGO 98 F & G34WA	
DATE	UNSPECIFIED TOLERANCES ARE:
DATE	WHOLE DIM (IN) ± .1
DATE	ONE-PLACE (IN) ± .01
DATE	TWO-PLACE (IN) ± .001
DATE	ANGLE
DATE	THRU HOLE PROJECTION
DATE	DATE
LAYOUT NO. G34WA	TITLE WATER SYSTEM INSTL
SHEET 1 OF 4	DWG NO 126582

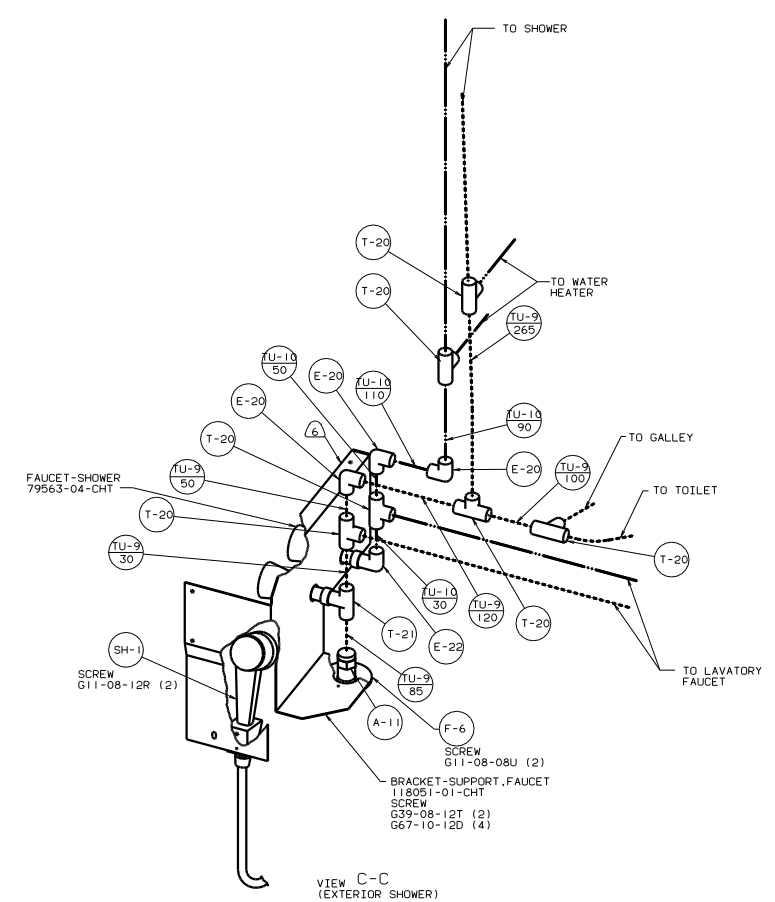
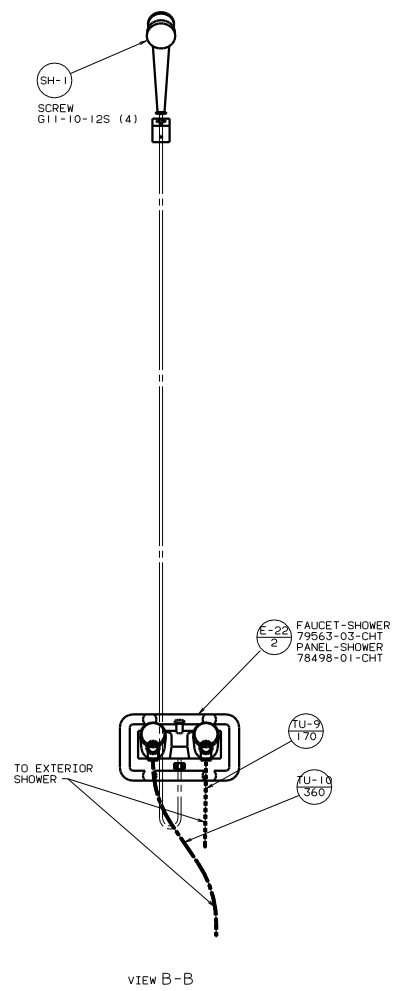

98 F & G34WA

TITLE		126582	
WATER SYSTEM INSTL			
NO. OF SHEETS	TOTAL SHEETS	DATE	BY
2 OF 4	4		

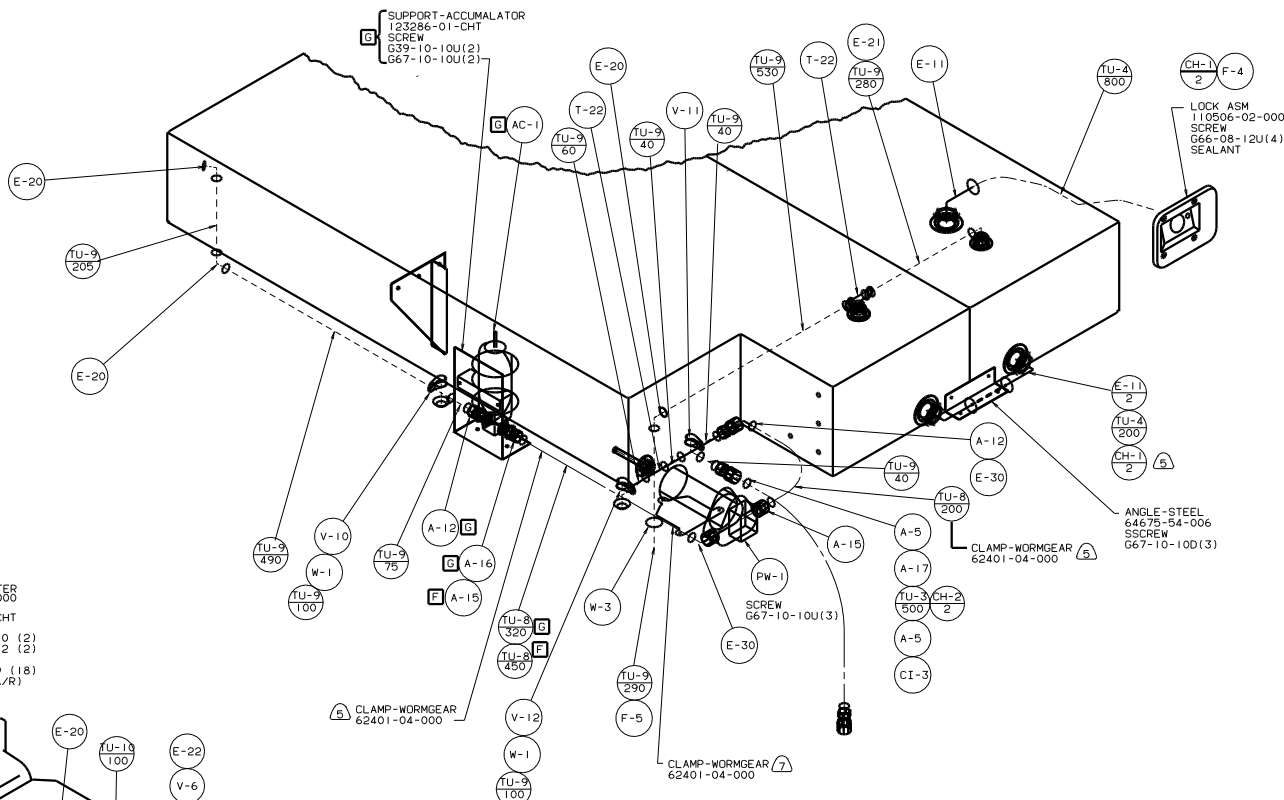

VIEW D-D

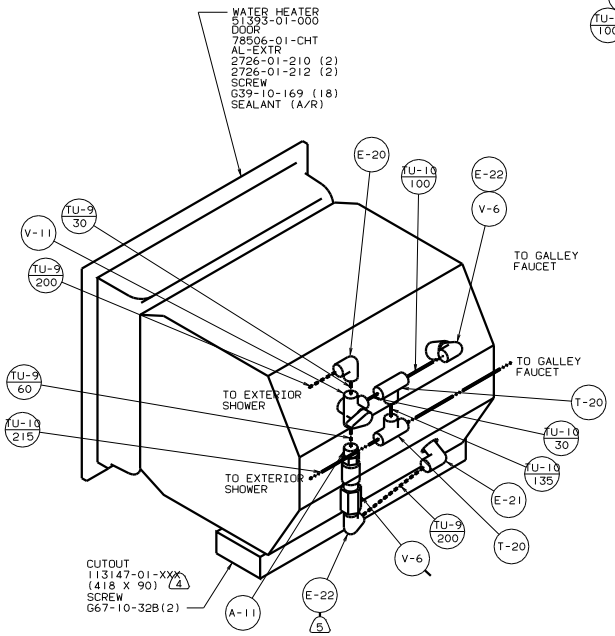

VIEW F-F

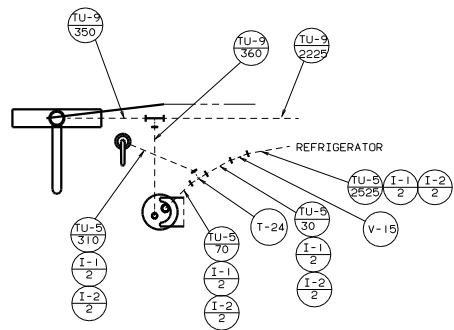

VIEW E-E [G]  
 29B WATER PURIFIER  
 54D ICE MAKER

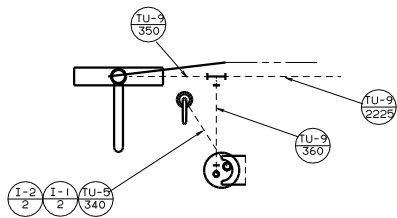

VIEW E-E [G]  
 29B WATER PURIFIER

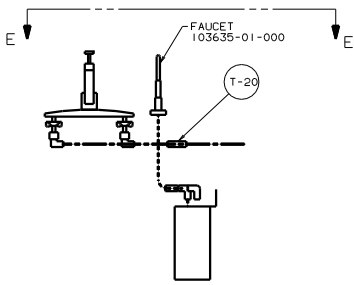

VIEW A-A [G]

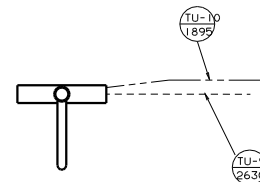

VIEW E-E

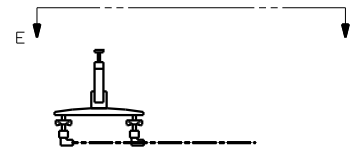

VIEW A-A  
 501 WATER PURIFIER WITHOUT