

VIEW A-A

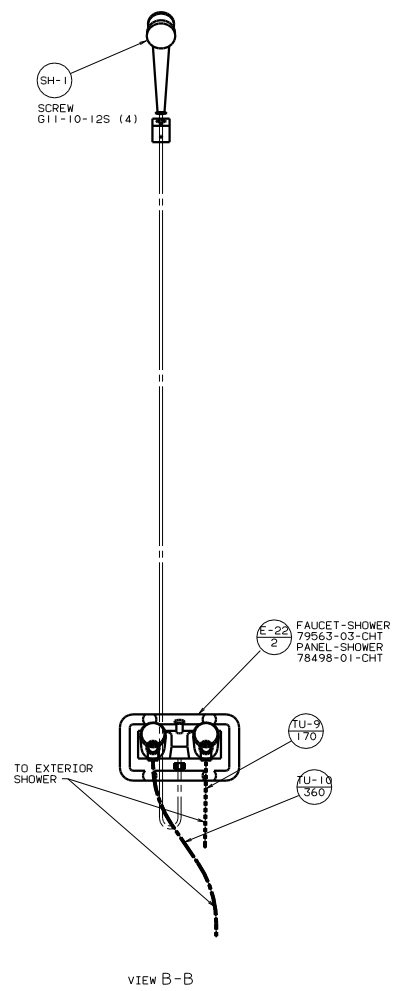

VIEW B-B

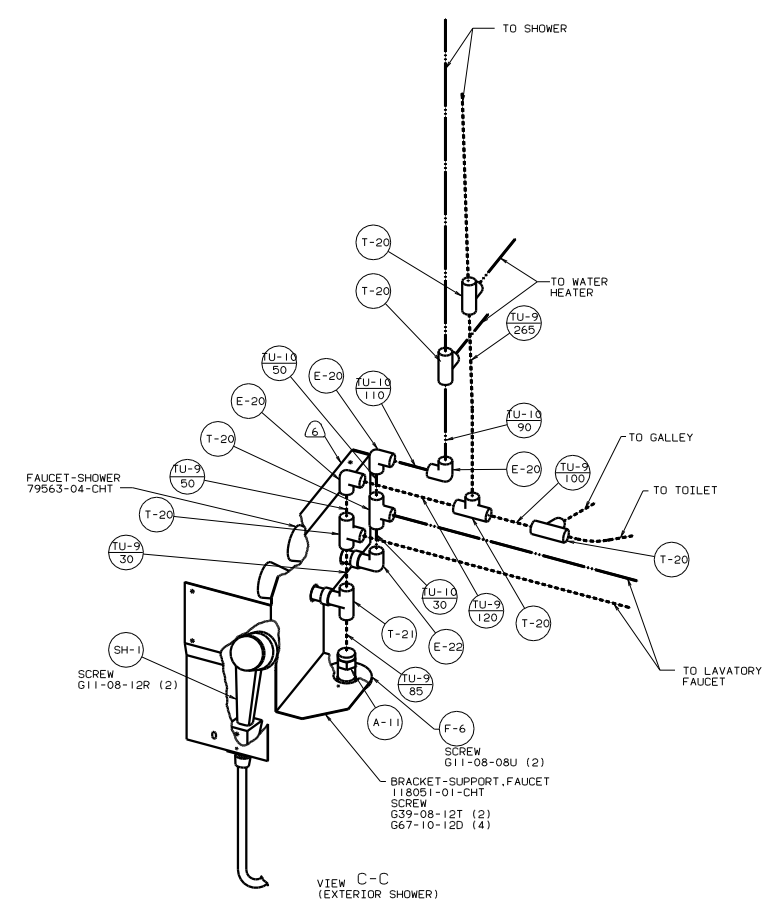

VIEW C-C
(EXTERIOR SHOWER)

98 F & G34WA

TITLE: WATER SYSTEM INSTL	
NO. OF SHEETS	REV.
SHEET 2 OF 4	1 E
126582	

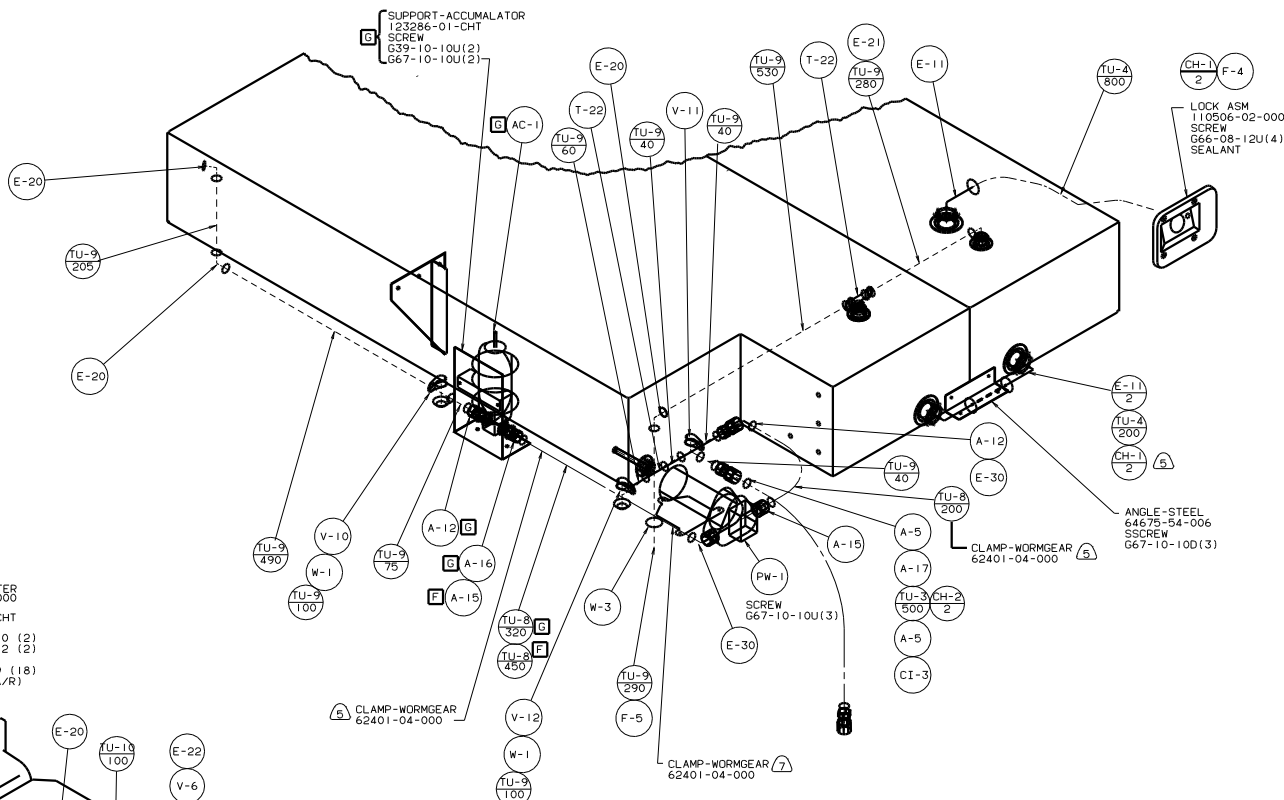

VIEW D-D

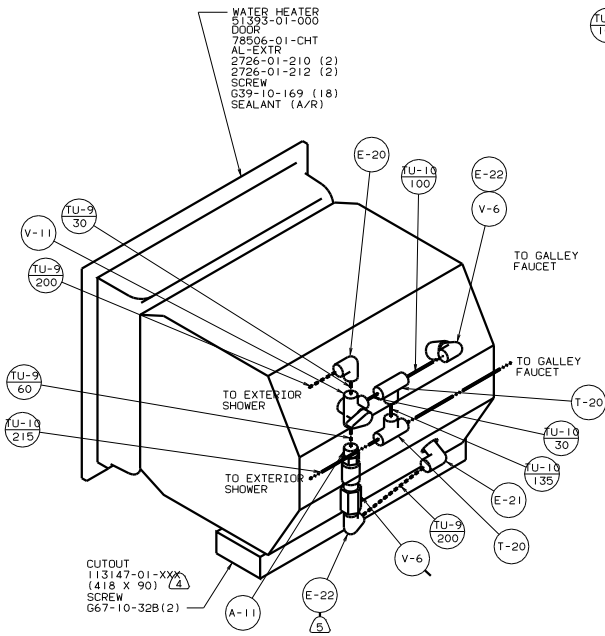

VIEW F-F

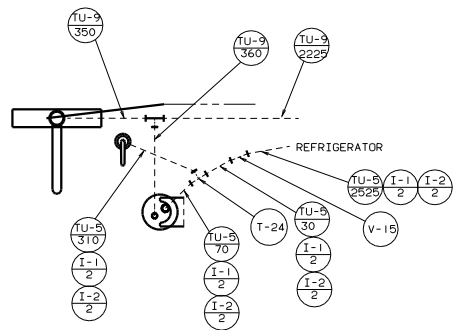

VIEW E-E [G]
29B WATER PURIFIER
54D ICE MAKER

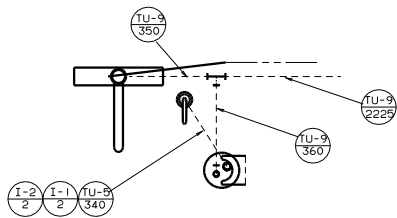

VIEW E-E [G]
29B WATER PURIFIER

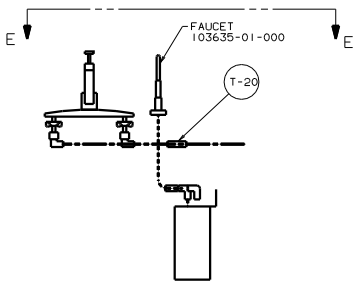

VIEW A-A [G]

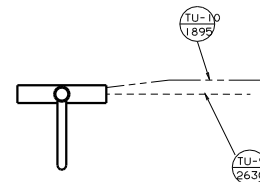

VIEW E-E

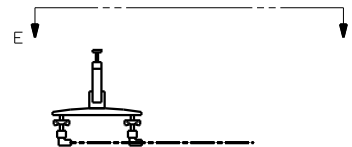

VIEW A-A
501 WATER PURIFIER WITHOUT