

FAUCET-LAVATORY 79527-01-CHT

SH-1
SCREW
G11-10-12S (4)

CH-1 F-4
LOCK ASM
110506-02-000
SCREW
G66-08-12U (4)
SEALANT

E-11 2
TU-2 200
CH-1 2

VIEW E-E

CLAMP-WORMGEAR
62401-04-000(2)

CLAMP-WORMGEAR
62401-04-000(2)

SUPPORT-ACCUMULATOR
123286-01-CHT
SCREW
G39-10-10U(2)
G67-10-10U(2)

WASHER-PLASTIC
87080-07-CHT(3)
SCREW
G67-10-10U(6)

SCREW
G67-10-10U(3)

PANEL-SHOWER
78498-01-CHT

FAUCET
78503-01-CHT

TO WATER
PUMP

TO WATER
HEATER

DETAIL B

97 G32W0

TITLE		WATER SYSTEM INSTL	
NO. OF SHEETS	2	OF	4
SHEET NO.	2	REV.	1
DATE		122972	

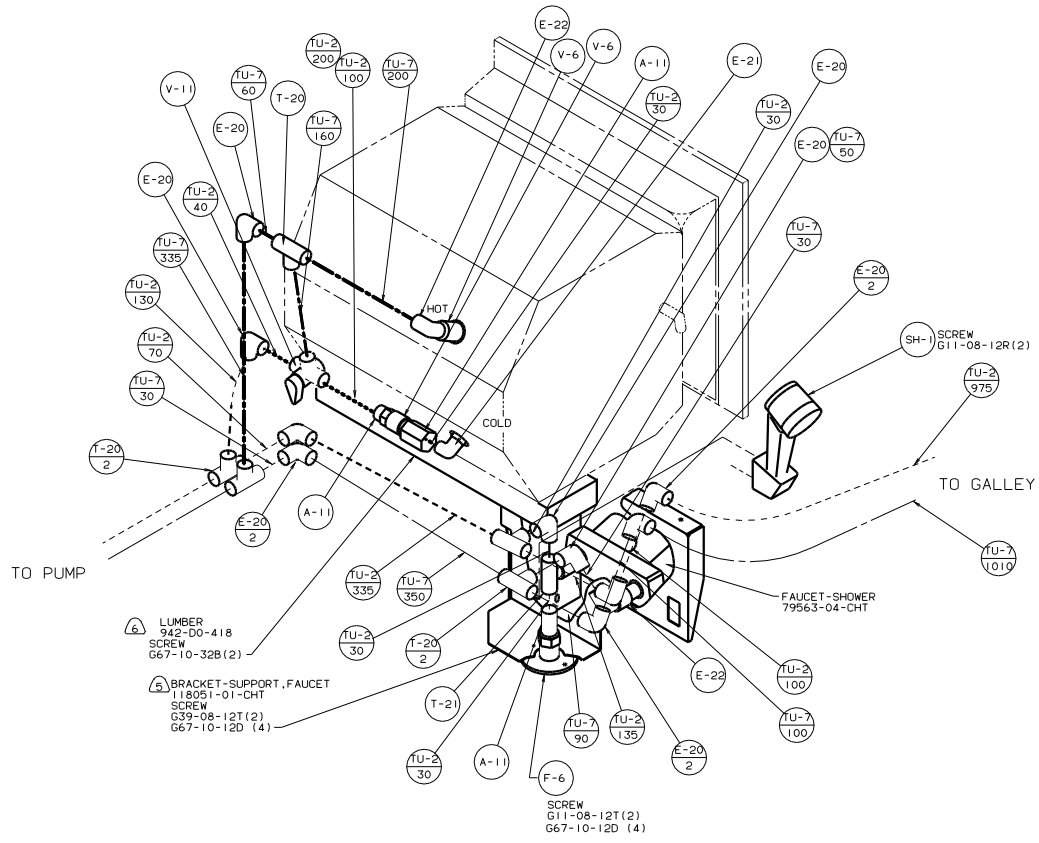

DETAIL A

97 G32WQ	
TITLE: WATER SYSTEM INSTL	
NO. OF SHEETS	TOTAL SHEETS
SHEET 3 OF 4	16
122972	

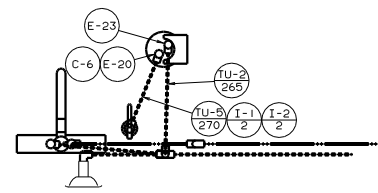
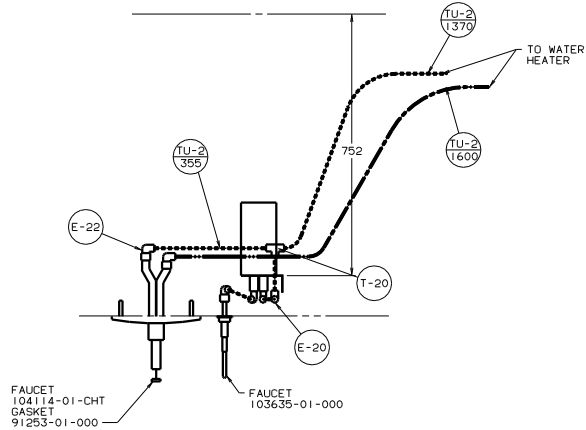

VIEW D-D
SINGLE CONTROL FAUCET
WITH PURIFIER

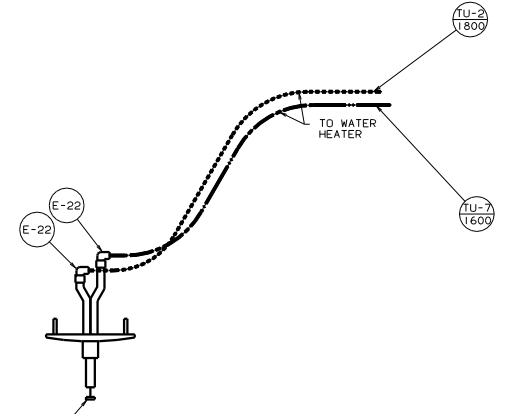

FAUCET
104114-01-CHT
GASKET
91253-01-000
VIEW D-D
SINGLE CONTROL FAUCET
WITHOUT PURIFIER

TITLE		97 G32WQ	
WATER SYSTEM INSTL		122972	
NO. OF SHEETS	TOTAL SHEETS	DATE	REV.
4 of 4	4		1