

SINK-SST, DOUBLE  
 110654-01-000 (US/CAN)  
 STRAINER  
 92303-01-000 (2)  
 SEAL  
 69640-01-000  
 RETAINER  
 105497-01-000 (2)  
 105497-02-000 (4)  
 SCREW  
 G67-06-10U (22)

TANK-HOLDING, 50 GALLON  
 104352-16-000  
 PLATFORM ASM-HOLDING TANK  
 105193-01-000  
 105193-02-000

TANK-HOLDING, 46 GALLON  
 112789-03-000  
 PLATFORM ASM-HOLDING TANK  
 112784-01-XXX  
 112784-02-XXX

BRACKET  
 95061-01-000 (2)  
 SCREW  
 G67-10-12B (2)  
 CLAMP  
 62401-02-000

BRACKET  
 95061-01-000 (2)  
 SCREW  
 G67-10-12B (2)  
 CLAMP  
 62401-02-000

BRACKET  
 95061-01-000 (10)  
 SCREW  
 G67-10-12B

BRACKET  
 95061-01-000 (10)  
 SCREW  
 G67-10-12B

FRONT AXLE  
 DATUM FRONT EDGE OF FLOOR

TOP FLOOR TUBE

TOILET-CHINA  
 85321-04-CHT

BRACKET  
 94756-03-XXX  
 SCREW  
 G39-10-12D (3)  
 NUT  
 D39-05-00B (2)  
 BRACKET  
 111316-01-000

CLAMP  
 62401-05-000  
 CLAMP  
 62401-05-000 (2)

- (12) CSA ONLY.
- (11) US ONLY.
- (10) SECURE VENT TUBES TO FLOOR WITH BRACKET.
- (9) VENT PIPE MUST PROJECT 51 MM MIN AND 63.5 MM MAX ABOVE ROOF FOR PROPER FIT AND FUNCTION.
- 8. SEE DWG 61607-01-000 FOR INSTL OF GROMMETS.
- 7. SEAL ALL AROUND SHOWER WITH SILICONE.
- 6. FOR CAN UNITS EACH HOLDING TANK SHALL HAVE A CSA APPROVAL STAMPED NEAR THE IAMPO APPROVAL.
- 5. EXPOSED PIPE ABOVE ROOF TO BE PAINTED 37163-01-000.
- 4. ALL EXTERIOR OPENINGS AROUND PIPE TO BE SEALED WITH 110744-01-000.
- 3. ALL PIPE AND FITTINGS TO BE ASSEMBLED WITH SOLVENT 4020-01-000.
- 2. SLOPE OF TRAP ARM MUST BE 6 PER 305.
- 1. SLOPE OF HORIZONTAL PIPING TO BE 6 PER 305 MIN.

(X-X) FOR DRAINAGE CALLOUTS SEE DWG NO. 116229-01-000

WINNERAGO		95 G34WK
DATE	UNSPECIFIED TOLERANCES ARE:	MATERIAL
CHG#	WHOLE DIM (1)	F
REV	ONE PLACE (19, 31)	.
BY	TWO PLACE (19, 30)	.
CHK	THREE PLACE (19, 30)	.
APP	FOUR PLACE (19, 30)	.
DATE	FIVE PLACE (19, 30)	.
DATE	SIX PLACE (19, 30)	.
DATE	SEVEN PLACE (19, 30)	.
DATE	EIGHT PLACE (19, 30)	.
DATE	NINE PLACE (19, 30)	.
DATE	TEN PLACE (19, 30)	.
DATE	ELEVEN PLACE (19, 30)	.
DATE	TWELVE PLACE (19, 30)	.
DATE	THIRTEEN PLACE (19, 30)	.
DATE	FOURTEEN PLACE (19, 30)	.
DATE	FIFTEEN PLACE (19, 30)	.
DATE	SIXTEEN PLACE (19, 30)	.
DATE	SEVENTEEN PLACE (19, 30)	.
DATE	EIGHTEEN PLACE (19, 30)	.
DATE	NINETEEN PLACE (19, 30)	.
DATE	TWENTY PLACE (19, 30)	.
DATE	TWENTY ONE PLACE (19, 30)	.
DATE	TWENTY TWO PLACE (19, 30)	.
DATE	TWENTY THREE PLACE (19, 30)	.
DATE	TWENTY FOUR PLACE (19, 30)	.
DATE	TWENTY FIVE PLACE (19, 30)	.
DATE	TWENTY SIX PLACE (19, 30)	.
DATE	TWENTY SEVEN PLACE (19, 30)	.
DATE	TWENTY EIGHT PLACE (19, 30)	.
DATE	TWENTY NINE PLACE (19, 30)	.
DATE	THIRTY PLACE (19, 30)	.
DATE	THIRTY ONE PLACE (19, 30)	.
DATE	THIRTY TWO PLACE (19, 30)	.
DATE	THIRTY THREE PLACE (19, 30)	.
DATE	THIRTY FOUR PLACE (19, 30)	.
DATE	THIRTY FIVE PLACE (19, 30)	.
DATE	THIRTY SIX PLACE (19, 30)	.
DATE	THIRTY SEVEN PLACE (19, 30)	.
DATE	THIRTY EIGHT PLACE (19, 30)	.
DATE	THIRTY NINE PLACE (19, 30)	.
DATE	FOURTY PLACE (19, 30)	.
DATE	FOURTY ONE PLACE (19, 30)	.
DATE	FOURTY TWO PLACE (19, 30)	.
DATE	FOURTY THREE PLACE (19, 30)	.
DATE	FOURTY FOUR PLACE (19, 30)	.
DATE	FOURTY FIVE PLACE (19, 30)	.
DATE	FOURTY SIX PLACE (19, 30)	.
DATE	FOURTY SEVEN PLACE (19, 30)	.
DATE	FOURTY EIGHT PLACE (19, 30)	.
DATE	FOURTY NINE PLACE (19, 30)	.
DATE	FIFTY PLACE (19, 30)	.
DATE	FIFTY ONE PLACE (19, 30)	.
DATE	FIFTY TWO PLACE (19, 30)	.
DATE	FIFTY THREE PLACE (19, 30)	.
DATE	FIFTY FOUR PLACE (19, 30)	.
DATE	FIFTY FIVE PLACE (19, 30)	.
DATE	FIFTY SIX PLACE (19, 30)	.
DATE	FIFTY SEVEN PLACE (19, 30)	.
DATE	FIFTY EIGHT PLACE (19, 30)	.
DATE	FIFTY NINE PLACE (19, 30)	.
DATE	SIXTY PLACE (19, 30)	.
DATE	SIXTY ONE PLACE (19, 30)	.
DATE	SIXTY TWO PLACE (19, 30)	.
DATE	SIXTY THREE PLACE (19, 30)	.
DATE	SIXTY FOUR PLACE (19, 30)	.
DATE	SIXTY FIVE PLACE (19, 30)	.
DATE	SIXTY SIX PLACE (19, 30)	.
DATE	SIXTY SEVEN PLACE (19, 30)	.
DATE	SIXTY EIGHT PLACE (19, 30)	.
DATE	SIXTY NINE PLACE (19, 30)	.
DATE	SEVENTY PLACE (19, 30)	.
DATE	SEVENTY ONE PLACE (19, 30)	.
DATE	SEVENTY TWO PLACE (19, 30)	.
DATE	SEVENTY THREE PLACE (19, 30)	.
DATE	SEVENTY FOUR PLACE (19, 30)	.
DATE	SEVENTY FIVE PLACE (19, 30)	.
DATE	SEVENTY SIX PLACE (19, 30)	.
DATE	SEVENTY SEVEN PLACE (19, 30)	.
DATE	SEVENTY EIGHT PLACE (19, 30)	.
DATE	SEVENTY NINE PLACE (19, 30)	.
DATE	EIGHTY PLACE (19, 30)	.
DATE	EIGHTY ONE PLACE (19, 30)	.
DATE	EIGHTY TWO PLACE (19, 30)	.
DATE	EIGHTY THREE PLACE (19, 30)	.
DATE	EIGHTY FOUR PLACE (19, 30)	.
DATE	EIGHTY FIVE PLACE (19, 30)	.
DATE	EIGHTY SIX PLACE (19, 30)	.
DATE	EIGHTY SEVEN PLACE (19, 30)	.
DATE	EIGHTY EIGHT PLACE (19, 30)	.
DATE	EIGHTY NINE PLACE (19, 30)	.
DATE	NINETY PLACE (19, 30)	.
DATE	NINETY ONE PLACE (19, 30)	.
DATE	NINETY TWO PLACE (19, 30)	.
DATE	NINETY THREE PLACE (19, 30)	.
DATE	NINETY FOUR PLACE (19, 30)	.
DATE	NINETY FIVE PLACE (19, 30)	.
DATE	NINETY SIX PLACE (19, 30)	.
DATE	NINETY SEVEN PLACE (19, 30)	.
DATE	NINETY EIGHT PLACE (19, 30)	.
DATE	NINETY NINE PLACE (19, 30)	.
DATE	HUNDRED PLACE (19, 30)	.

SINK-LAVATORY  
105921-01-CHT  
STRAINER  
106116-01-CHT  
SEALER  
69640-01-000  
SPACER-SINK  
105218-01-CHT

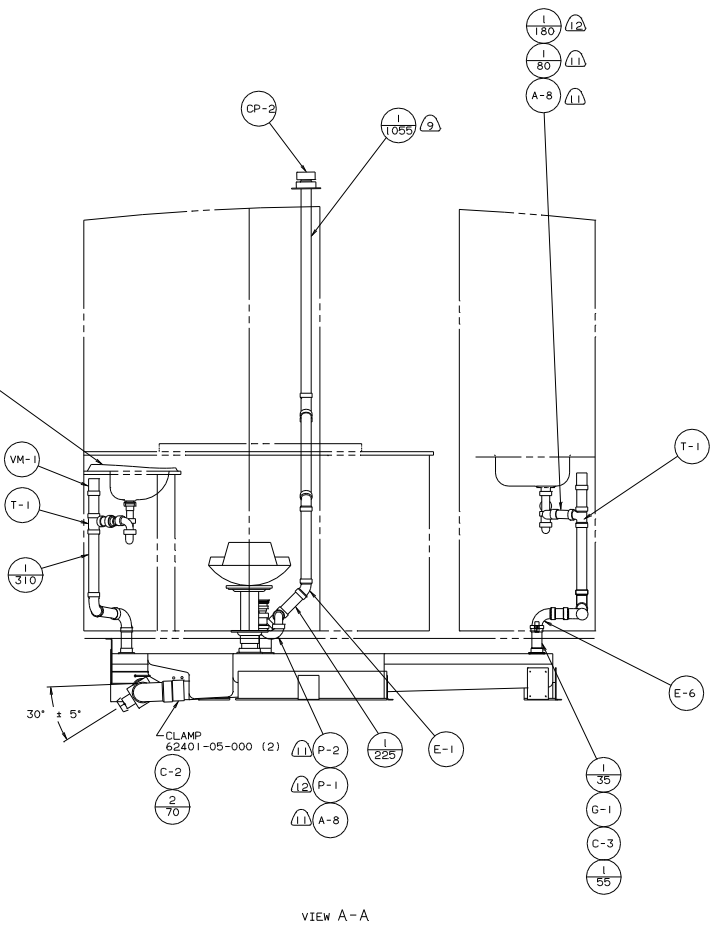

VIEW A-A

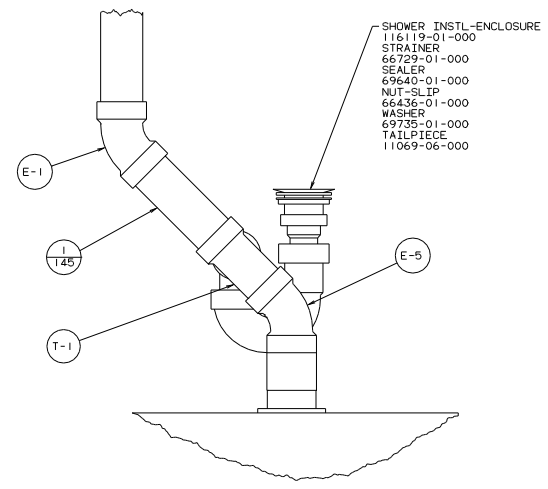

VIEW B-B

TITLE: DRAINAGE SYSTEM INSTL		DESIGN NO: 117209	
30 NET SCALE DRAWING	SHEET 2 OF 2	DATE	1/1

95 G34WK

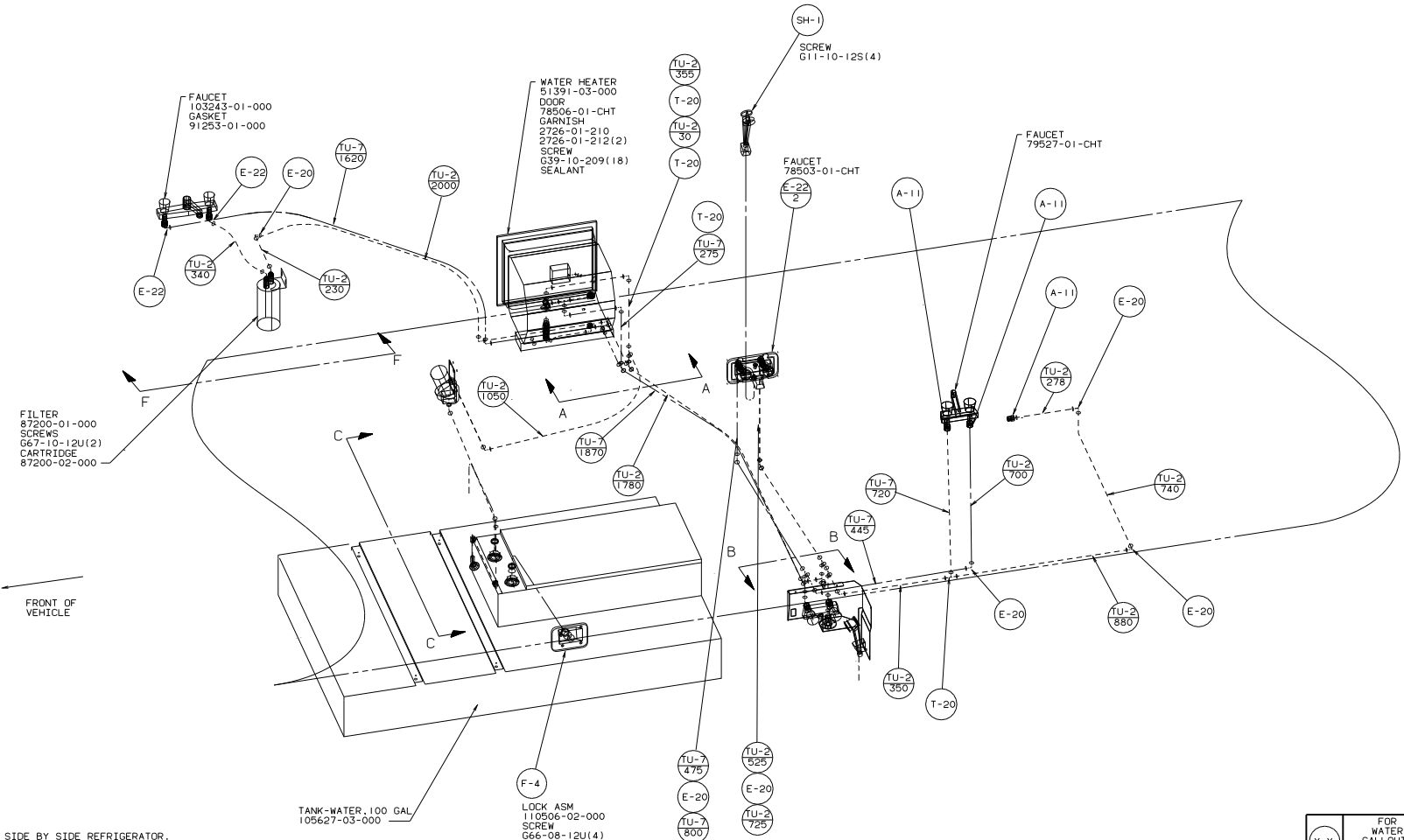

- ⑧ USE WITH SIDE BY SIDE REFRIGERATOR.
- ⑦ USE WITH WATER PURIFIER.
- ⑥ USE WITH DUAL CONTROL FAUCET.
- ⑤ USE WITH SINGLE CONTROL FAUCET.
- ④ LOCATE LUMBER TO SUPPORT WATER HEATER.

3. ALL TUBING TO BE SECURED AT 1200 INTERVALS MAX WITH CLIP 91951-01-000 AND SCREW G13-06-16U.
2. TUBING TO BE INSTALLED WITH SUFFICIENT SLOPE TO PROVIDE DRAINAGE TO NEAREST VALVE.
1. THREADED PLASTIC FITTINGS TO BE SEALED WITH SEALANT 84456-01-000.

NOTES:  
 Copyright 2009 Winnebago Industries, Inc.

X-X FOR WATER CALLOUTS SEE DWG NO. 116230-01-000

LEGEND	
HOT	-----
COLD	-----

		96 G34WK, PUSH
DFRB COND P.E. P.E. COND	UNFINISHED TOLERANCES ARE: HOLE DIA (1) : + .015 TWO-PLAGE (1) : + .015 HOLE : + .015 THIRD ANGLE PROJECTION	MATERIAL: 119033
LAYOUT NO: GK34WK TITLE: WATER SYSTEM INSTL SHEET 1 OF 4		REF: 117280

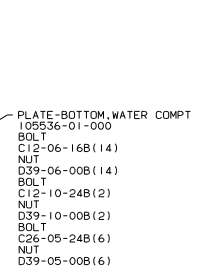
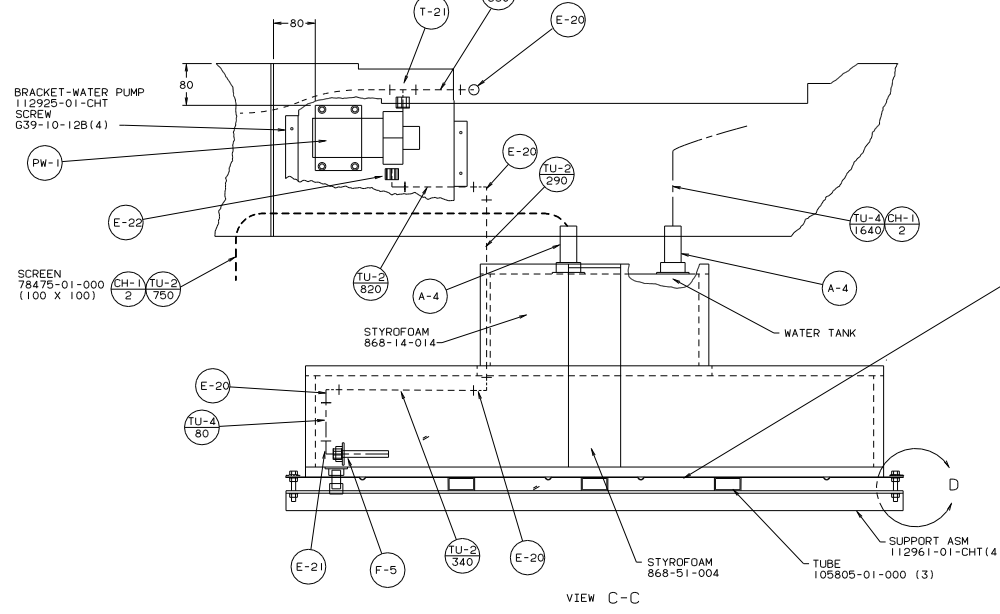
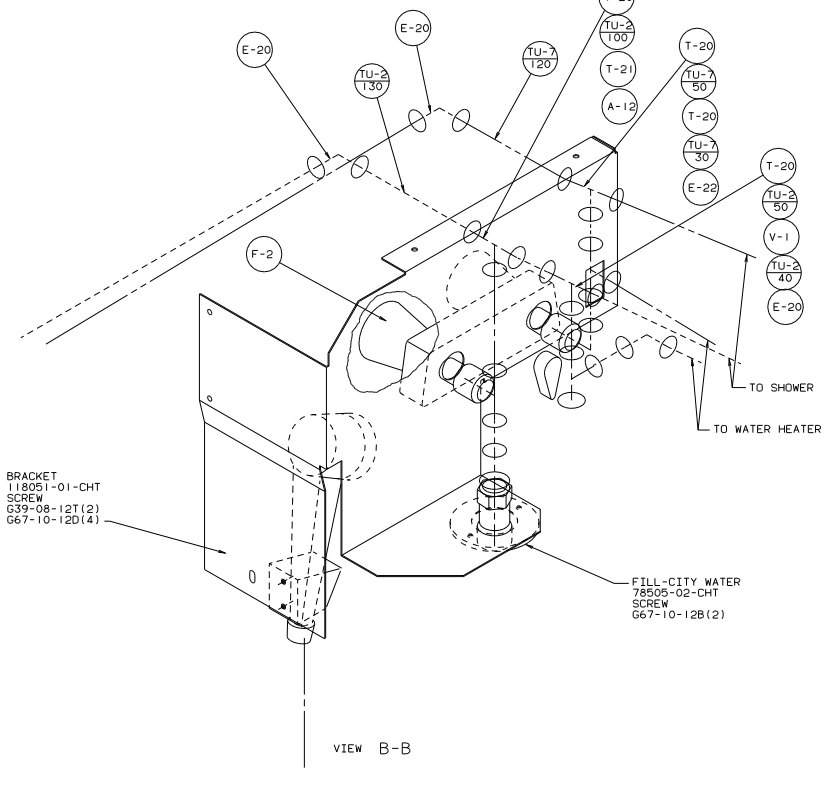
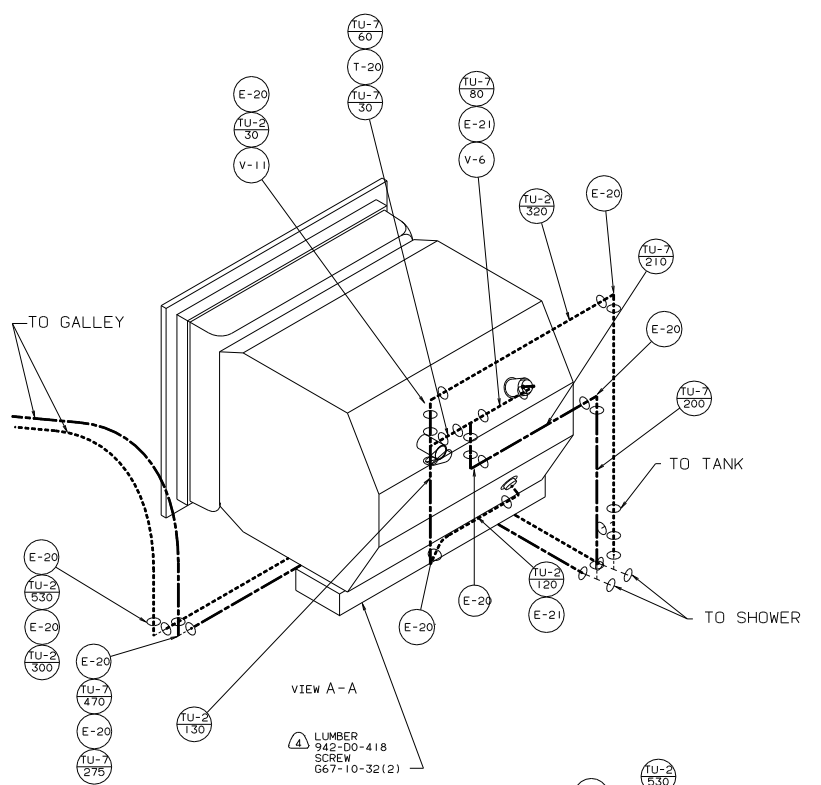

TITLE: WATER SYSTEM INSTL		DRAWING NO: 119033	
NO. SHEET	OF	SHEET	NO.
2	4	1	1

