

VIEW FROM Q OF VEHICLE

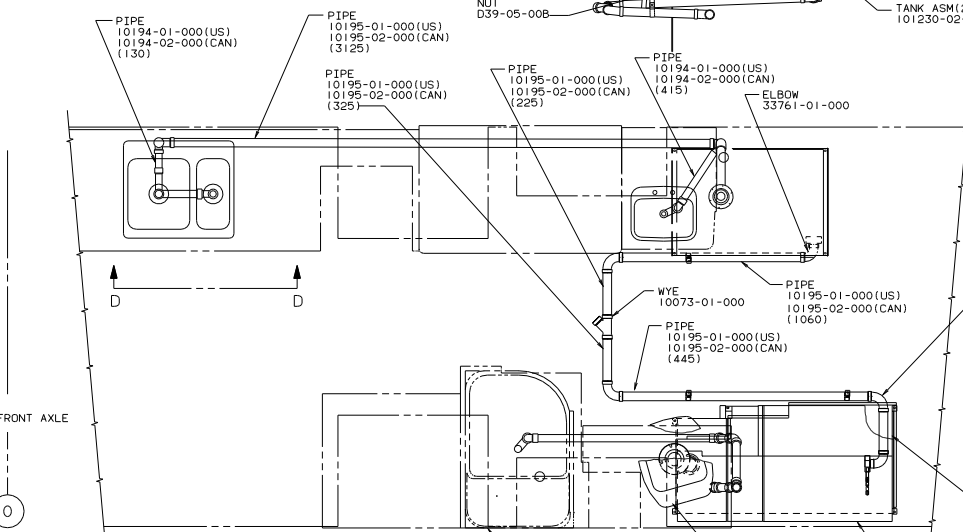

VIEW FROM Q OF VEHICLE

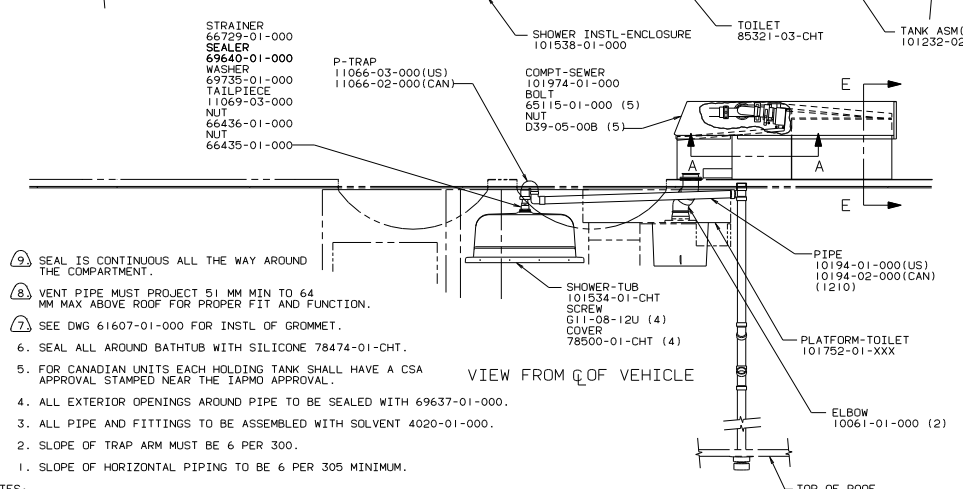

- NOTES:
- SEAL IS CONTINUOUS ALL THE WAY AROUND THE COMPARTMENT.
 - VENT PIPE MUST PROJECT 51 MM MIN TO 64 MM MAX ABOVE ROOF FOR PROPER FIT AND FUNCTION.
 - SEE DWG 61607-01-000 FOR INSTL OF GROMMET.
 - SEAL ALL AROUND BATHTUB WITH SILICONE 78474-01-CHT.
 - FOR CANADIAN UNITS EACH HOLDING TANK SHALL HAVE A CSA APPROVAL STAMPED NEAR THE IAPMO APPROVAL.
 - ALL EXTERIOR OPENINGS AROUND PIPE TO BE SEALED WITH 69637-01-000.
 - ALL PIPE AND FITTINGS TO BE ASSEMBLED WITH SOLVENT 4020-01-000.
 - SLOPE OF TRAP ARM MUST BE 6 PER 300.
 - SLOPE OF HORIZONTAL PIPING TO BE 6 PER 305 MINIMUM.

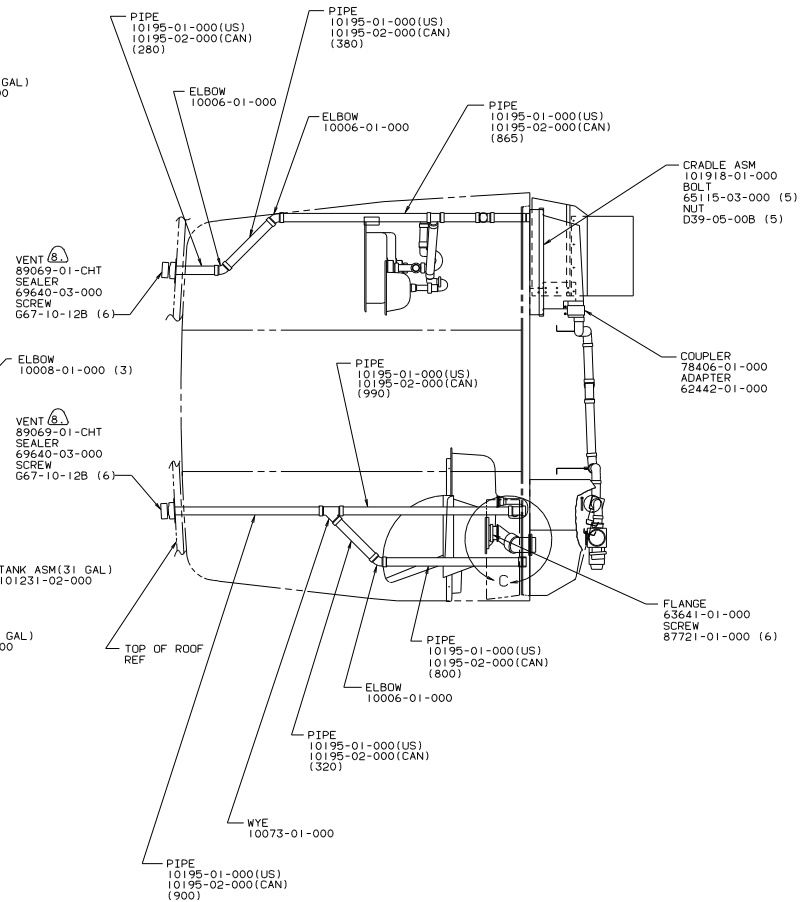

WINNEBAGO 91 W1CP37R0

OPTN	UNSPECIFIED TOLERANCES ARE MATERIAL.
CHRP	ANGLE DIM (1)
PLC	ONE-PLACE (19.21)
PLC	TWO-PLACE (19.200)
PLC	ANGLE
CONP	THIRD ANGLE PROJECTION

LANP P37R01 TITLE DRAINAGE SYSTEM INSTL
 DIA # SCALE: NONE DO NOT SCALE DRAWING FILE DRN
 ALL DIMENSIONS ARE IN MILLIMETERS SHEET 1 OF 2 101635

REF: 97765

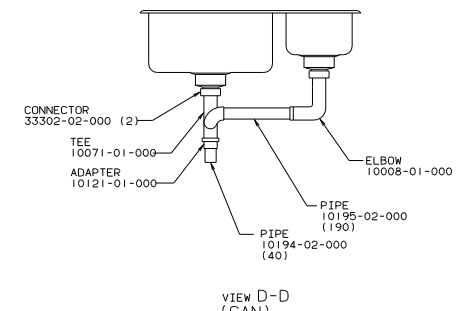
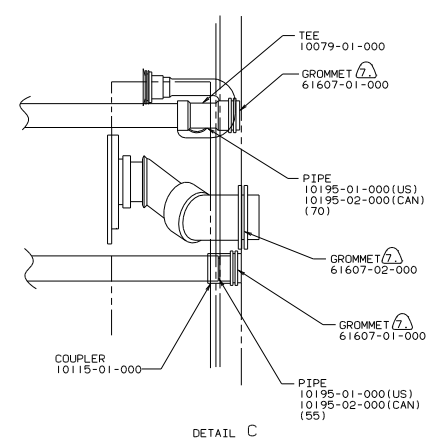
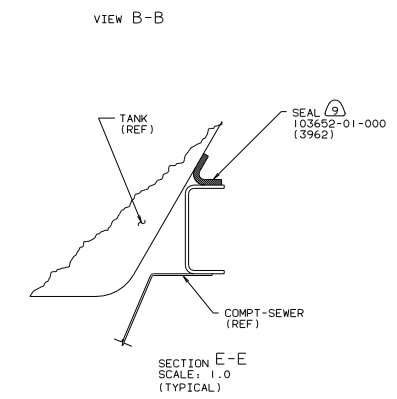
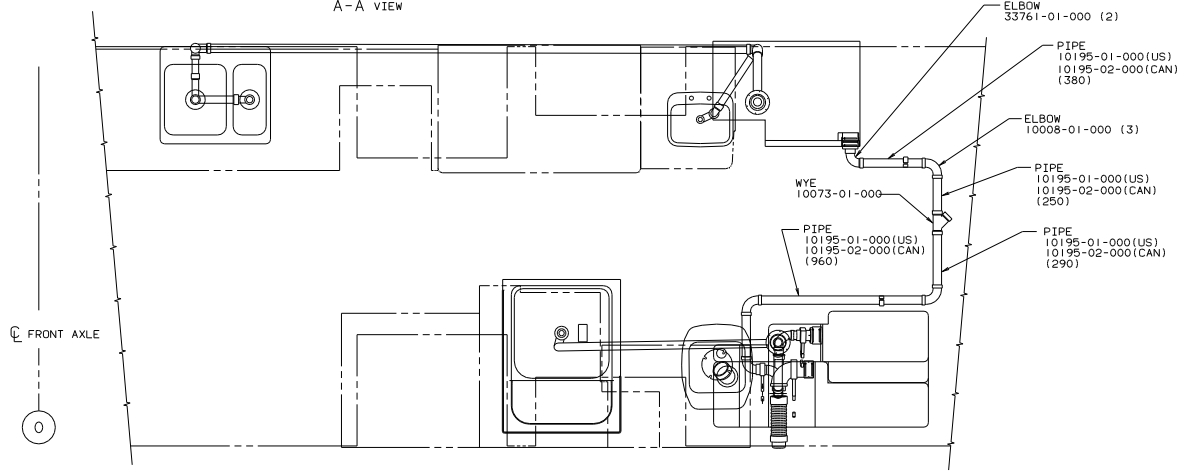
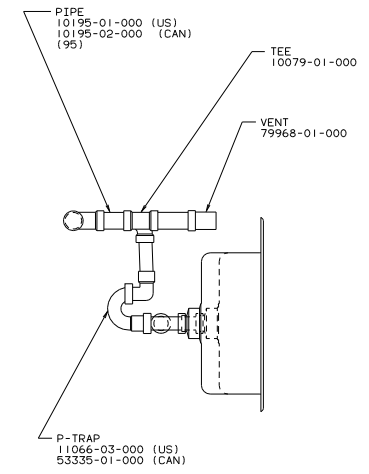
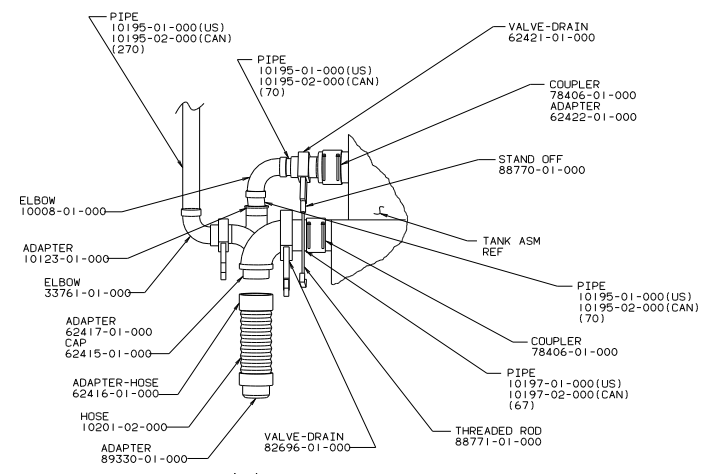

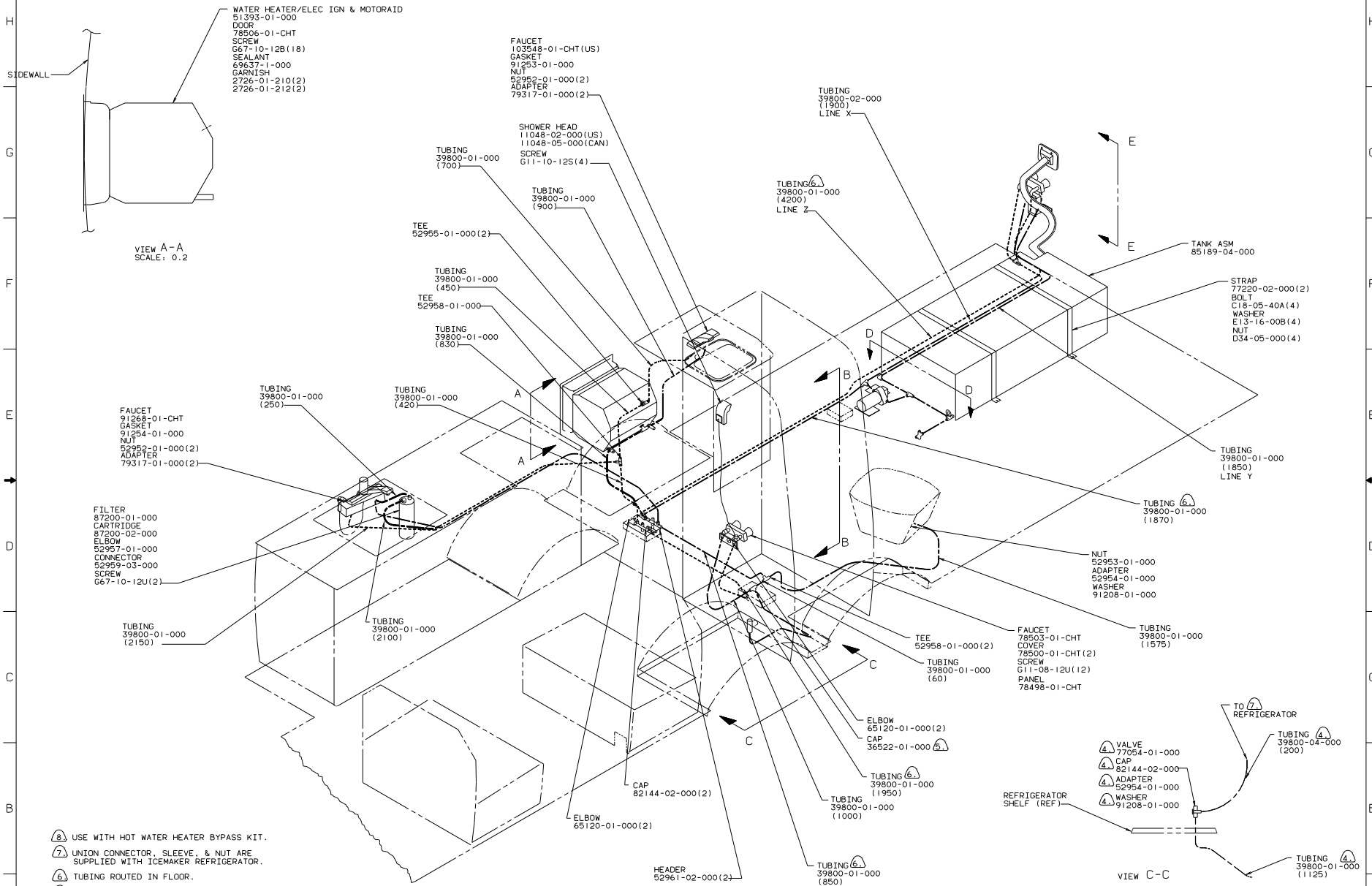

- Ⓐ USE WITH HOT WATER HEATER BYPASS KIT.
- Ⓙ UNION CONNECTOR, SLEEVE, & NUT ARE SUPPLIED WITH ICEMAKER REFRIGERATOR.
- Ⓜ TUBING ROUTED IN FLOOR.
- Ⓝ USE WITHOUT ICEMAKER IN REFRIGERATOR.
- Ⓚ USE WITH ICEMAKER IN REFRIGERATOR ONLY.

3. ALL TUBING TO BE SECURED AT 1200 INTERVALS MAX. WITH CLAMP 10495-01-000 AND SCREW G67-10-12B.
2. TUBING TO BE INSTALLED WITH SUFFICIENT SLOPE TO PROVIDE DRAINAGE TO NEAREST VALVE.
1. PLASTIC FITTINGS TO BE SEALED WITH SEALANT TAPE 9201-01-000.

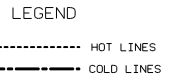

WINNIEGAGO 91 W/1CP37R0	
DATE	UNSPECIFIED TOLERANCES ARE MATERIAL.
DR	ANGLE DIM (R) + 1.5
CHK	ONE-PLANE (R, S) + 0.5
FILE	NO-PLATE (R, S)
PL	ANGLE
CDR	THRU-ANGLE PROJECTION
LAUNCH NO. P37R01	TITLE WATER SYSTEM INSL
DIA # SCALE: 0-1	NO. NET SCALE DRAWING
ALL DIMENSIONS ARE IN MILLIMETERS	SHEET 1 OF 3

REF: 97767 1

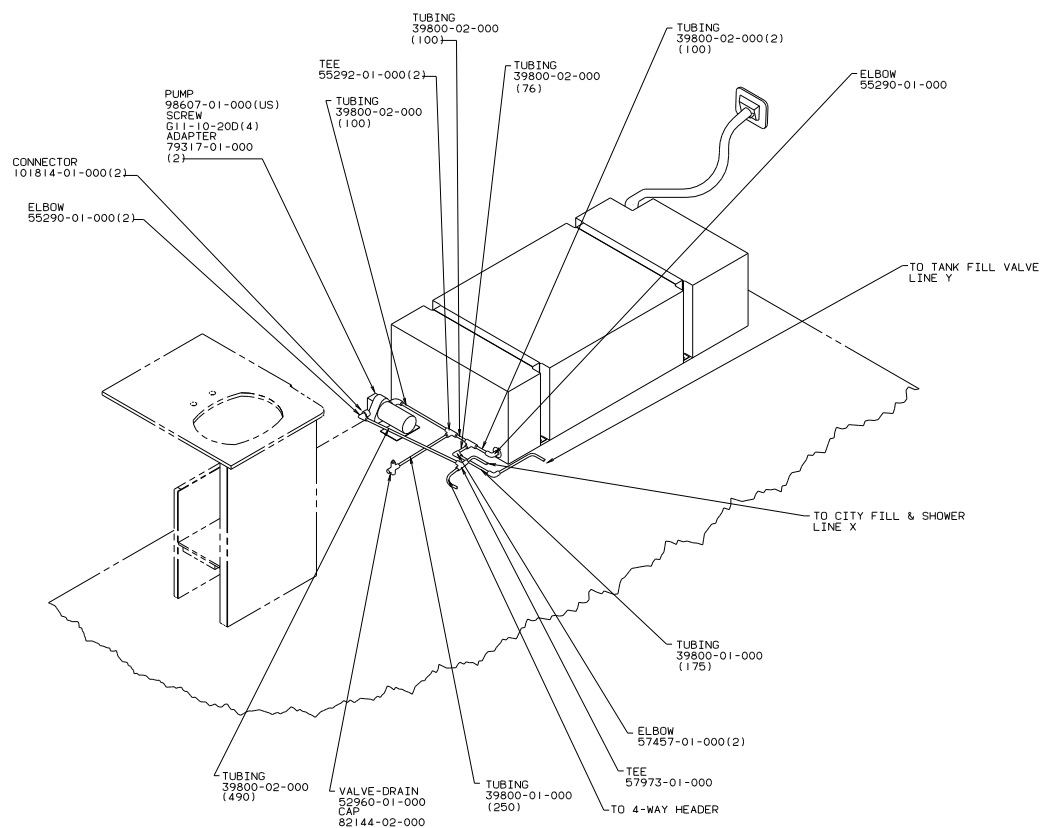

TWIN BED

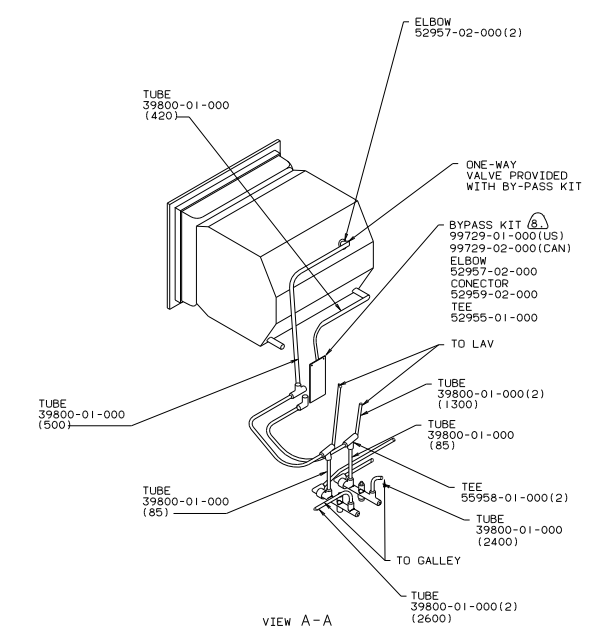

VIEW A-A

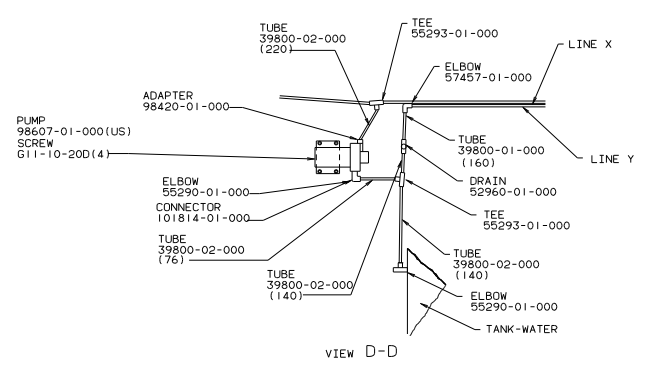

VIEW D-D

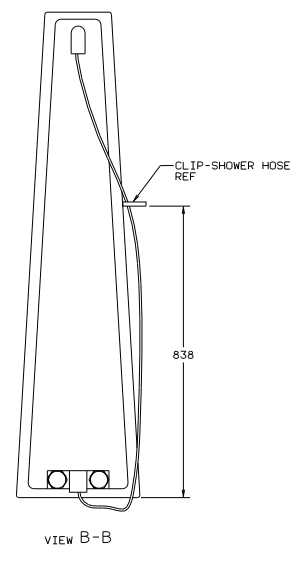

VIEW B-B

TITLE: WATER SYSTEM INSTL	
30 NET SCALE DRAWING	REV 1
SHEET 2 OF 3	DATE 101639

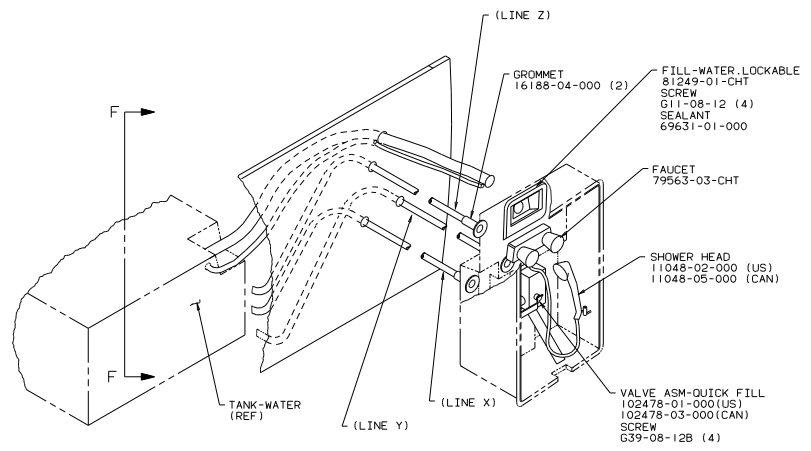

VIEW E-E
SCALE: 0.2

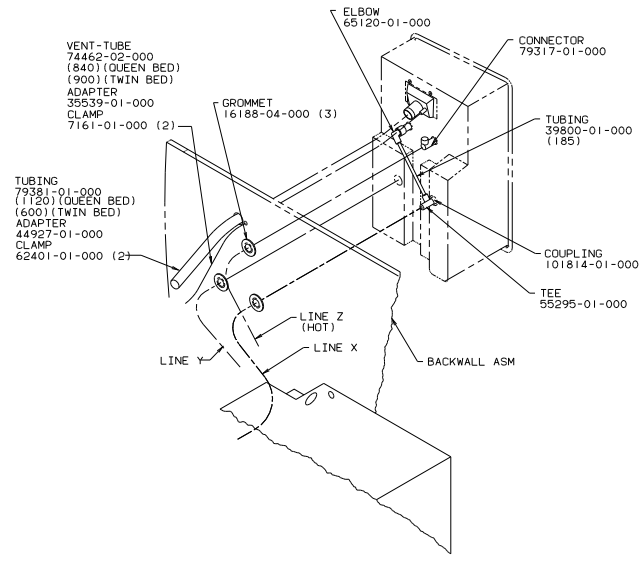

VIEW F-F
SCALE: 0.2