

REV	DATE	DFTR	ADM	DWG NO	99446
ECR	REV	ZONE	REVISION RECORD	DATE	DR CR

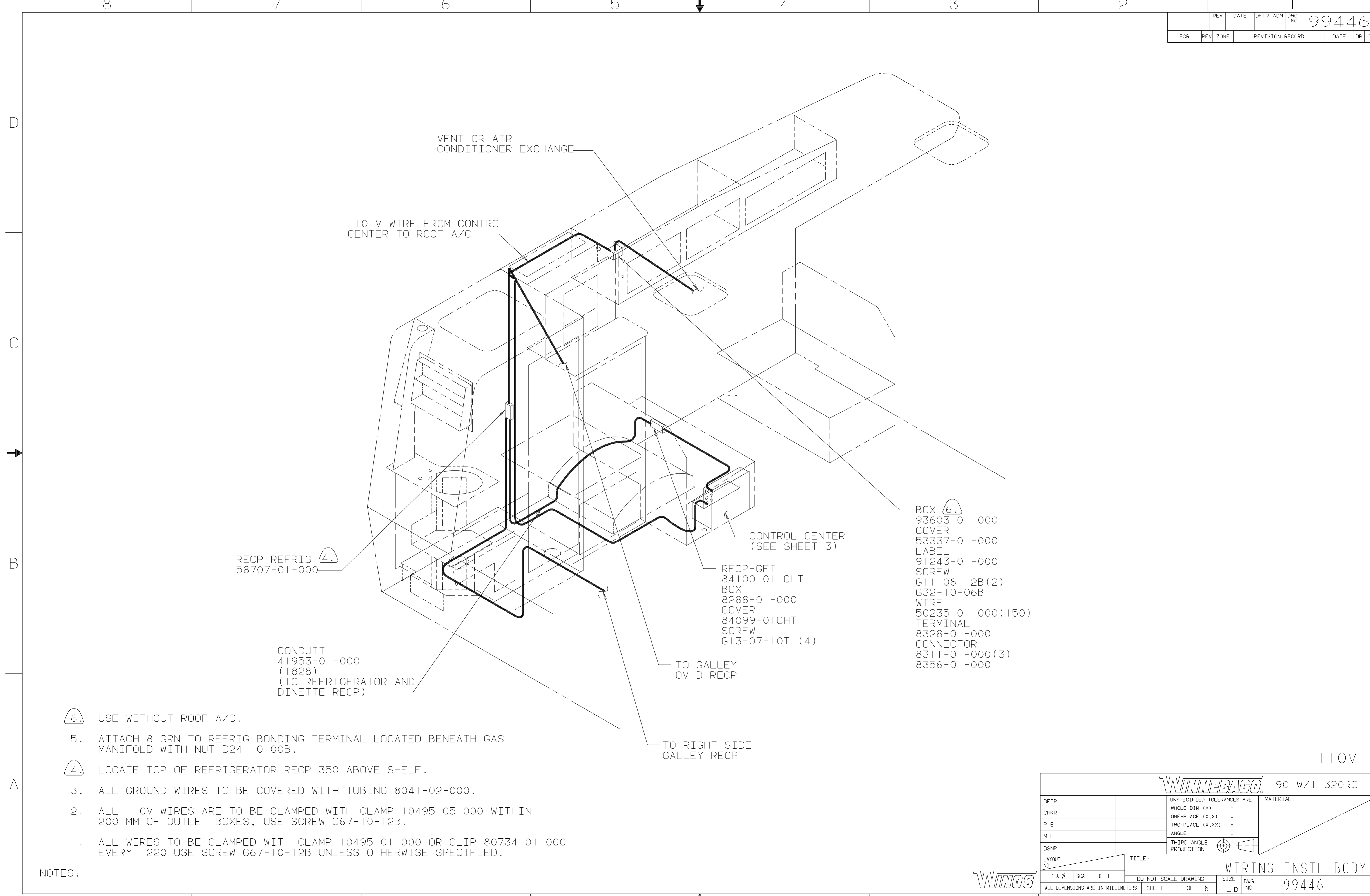

- NOTES:
6. USE WITHOUT ROOF A/C.
 5. ATTACH 8 GRN TO REFRIG BONDING TERMINAL LOCATED BENEATH GAS MANIFOLD WITH NUT D24-10-00B.
 4. LOCATE TOP OF REFRIGERATOR RECP 350 ABOVE SHELF.
 3. ALL GROUND WIRES TO BE COVERED WITH TUBING 8041-02-000.
 2. ALL 110V WIRES ARE TO BE CLAMPED WITH CLAMP 10495-05-000 WITHIN 200 MM OF OUTLET BOXES, USE SCREW G67-10-12B.
 1. ALL WIRES TO BE CLAMPED WITH CLAMP 10495-01-000 OR CLIP 80734-01-000 EVERY 1220 USE SCREW G67-10-12B UNLESS OTHERWISE SPECIFIED.

- BOX 6.
 93603-01-000
 COVER
 53337-01-000
 LABEL
 91243-01-000
 SCREW
 G11-08-12B (2)
 G32-10-06B
 WIRE
 50235-01-000 (150)
 TERMINAL
 8328-01-000
 CONNECTOR
 8311-01-000 (3)
 8356-01-000

110V

DFTR		UNSPECIFIED TOLERANCES ARE:		MATERIAL:	
CHKR		WHOLE DIM (X)	±		
P E		ONE-PLACE (X.X)	±		
M E		TWO-PLACE (X.XX)	±		
DSNR		ANGLE	±		
LAYOUT NO		THIRD ANGLE PROJECTION	☉		
TITLE:		WIRING INSTL-BODY			
DIA Ø	SCALE: 0.1	DO NOT SCALE DRAWING	SIZE	DWG NO	99446
ALL DIMENSIONS ARE IN MILLIMETERS		SHEET 1 OF 6	ID		

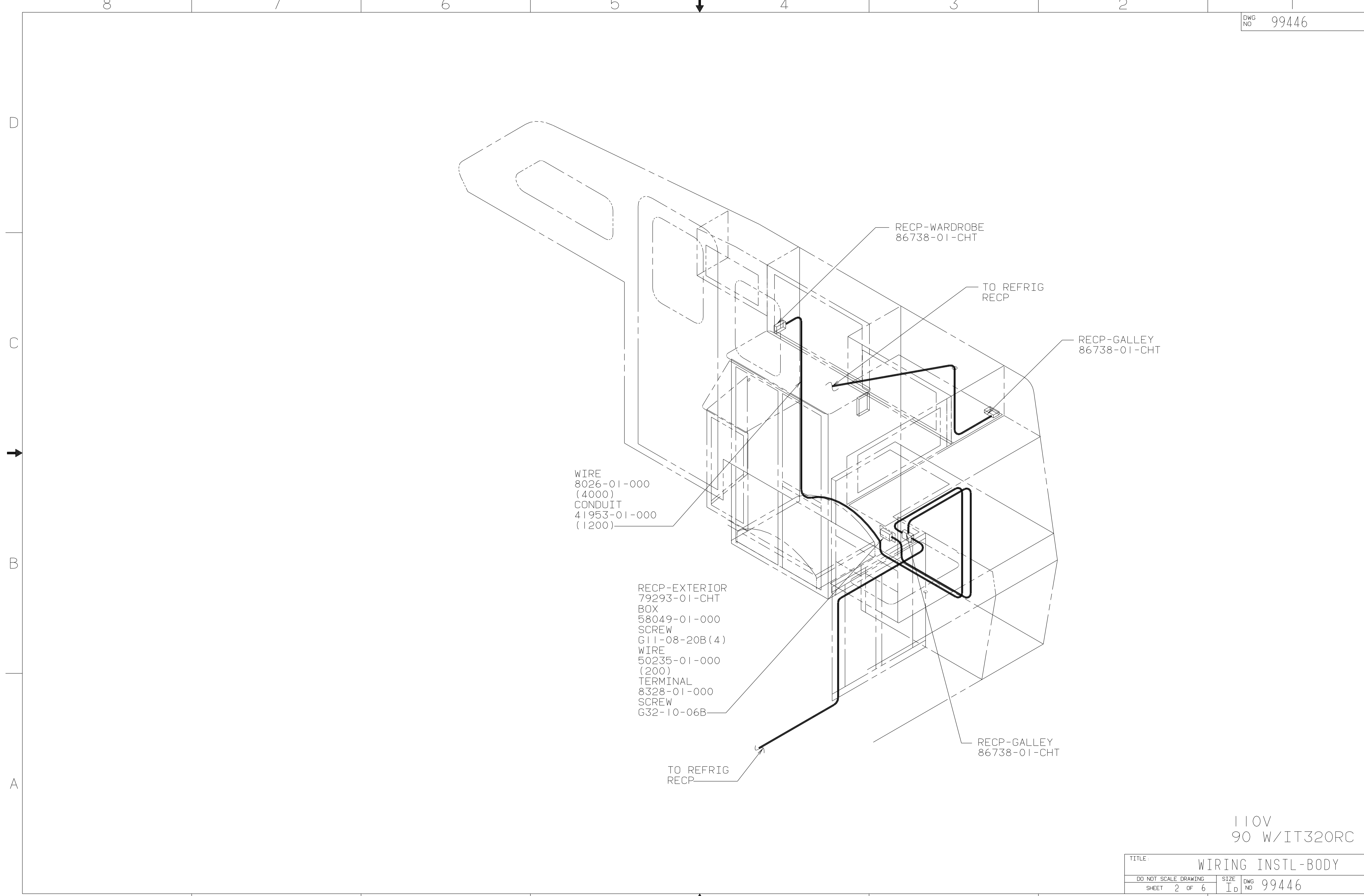

110V
90 W/IT320RC

TITLE: WIRING INSTL-BODY		
DO NOT SCALE DRAWING	SIZE I D	DWG NO 99446
SHEET 2 OF 6		

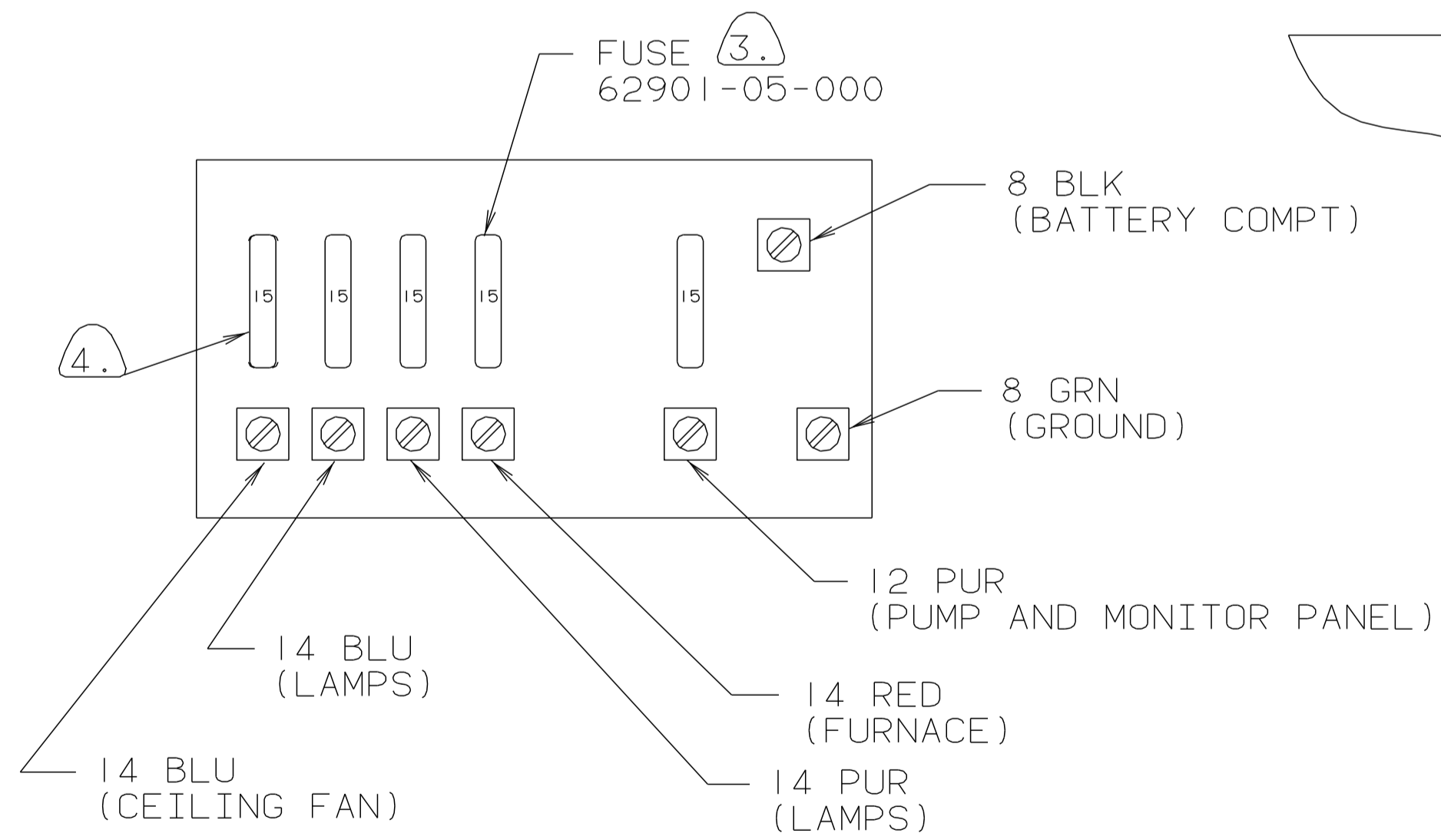
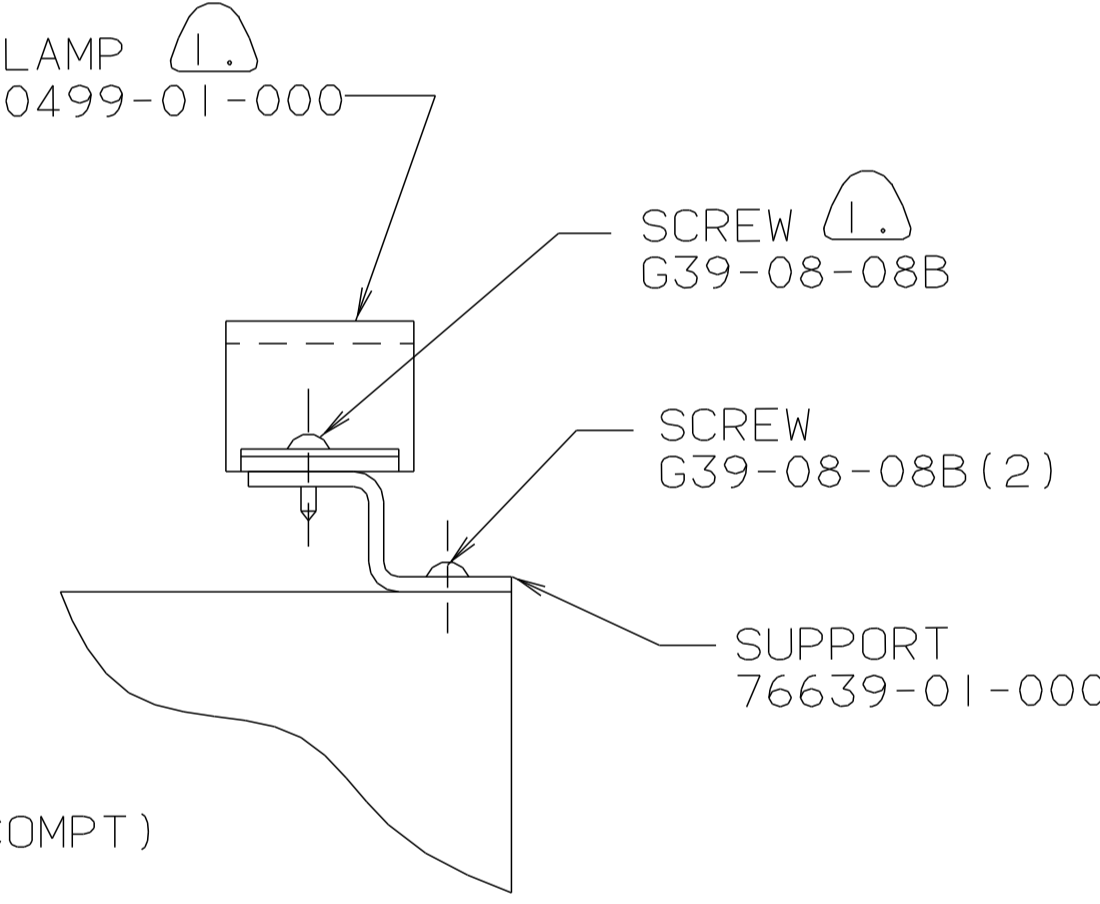
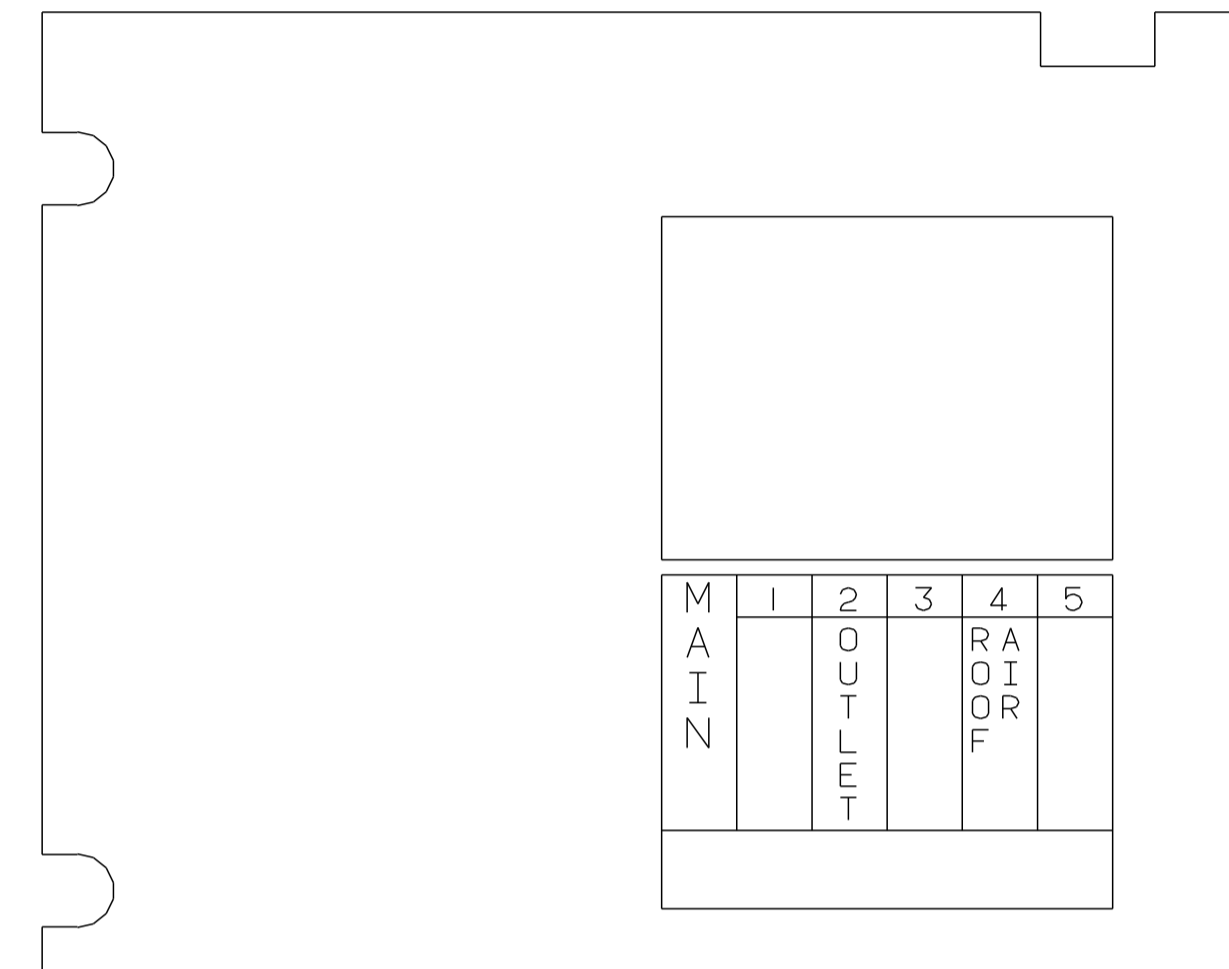
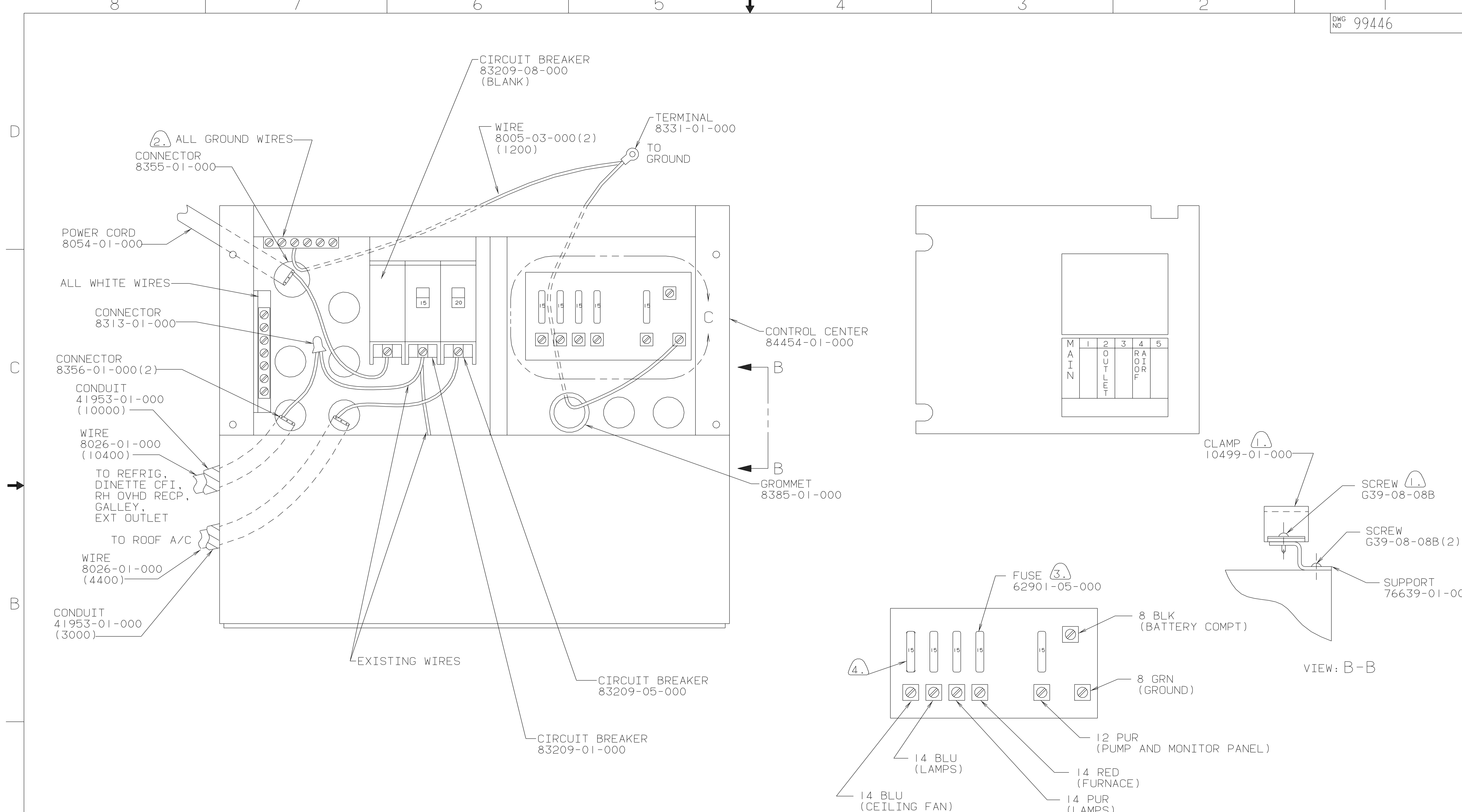

- NOTES:
- ④ USE WITH CEILING FAN ONLY.
 - ③ SUPPLIED WITH CONTROL CENTER.
 - ② ALL GROUND WIRES TO BE COVERED WITH TUBING 8041-02-000.
 - ① FASTEN ALL WIRES TO SUPPORT, USE ONE SCREW AND CLAMP, PER WIRE.

CONTROL CENTER
90 W/IT320RC

TITLE: WIRING INSTL-BODY		
DO NOT SCALE DRAWING	SIZE I D	DWG NO 99446
SHEET 3 OF 6		

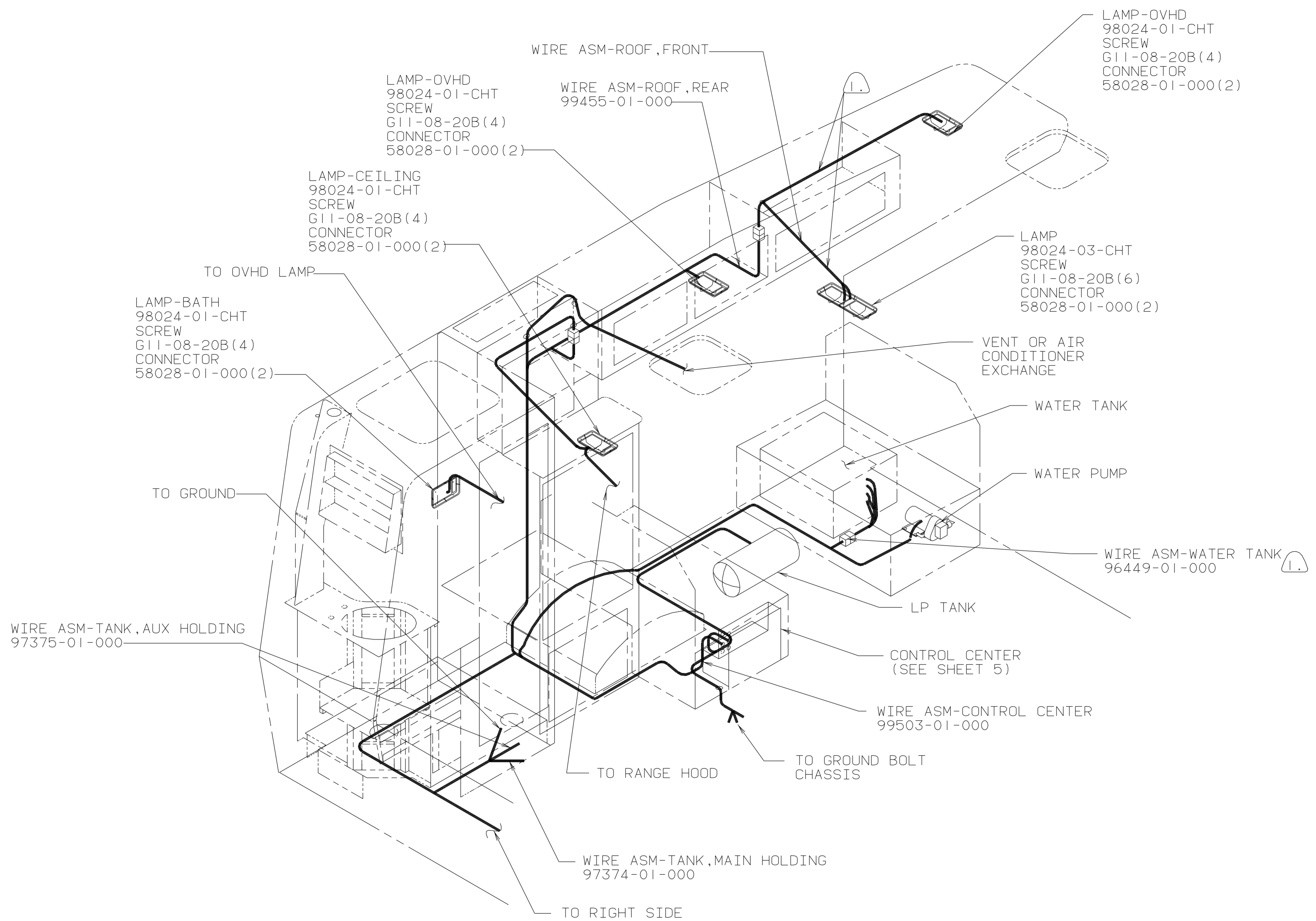

① WIRE ROUTED IN ROOF.

NOTES:

12V
90W/IT320RC

TITLE: WIRING INSTL-BODY			
DO NOT SCALE DRAWING	SIZE I.D	DWG NO	99446
SHEET 4 OF 6			

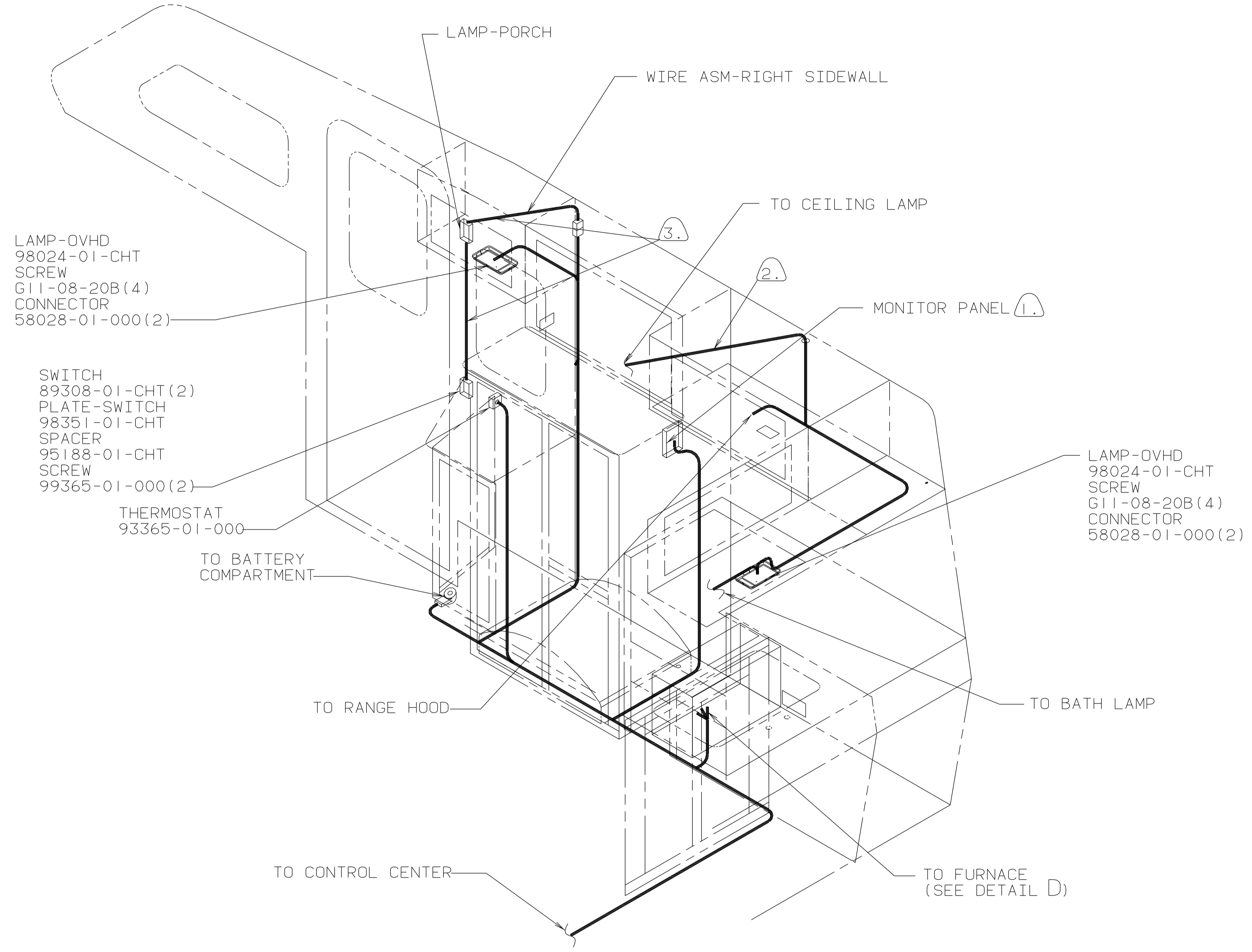
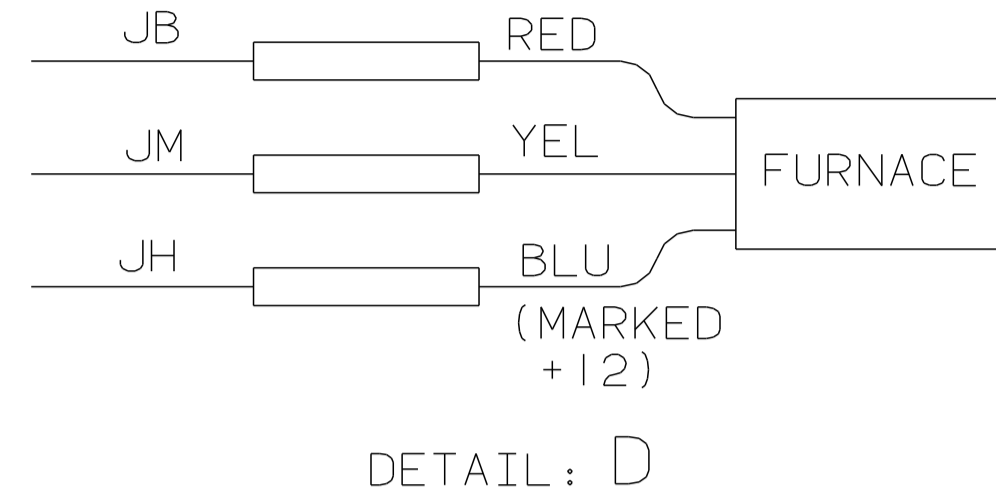

- NOTES:
- (3) WIRE ROUTED IN SIDEWALL.
 - (2) WIRE ROUTED IN ROOF.
 - (1) SEE DRAWING 72789-01-000 FOR MONITOR PANEL INSTALLATION.

12V
90 W/IT320RC

TITLE: WIRING INSTL-BODY	
DO NOT SCALE DRAWING	SIZE I D
SHEET 5 OF 6	DWG NO 99446

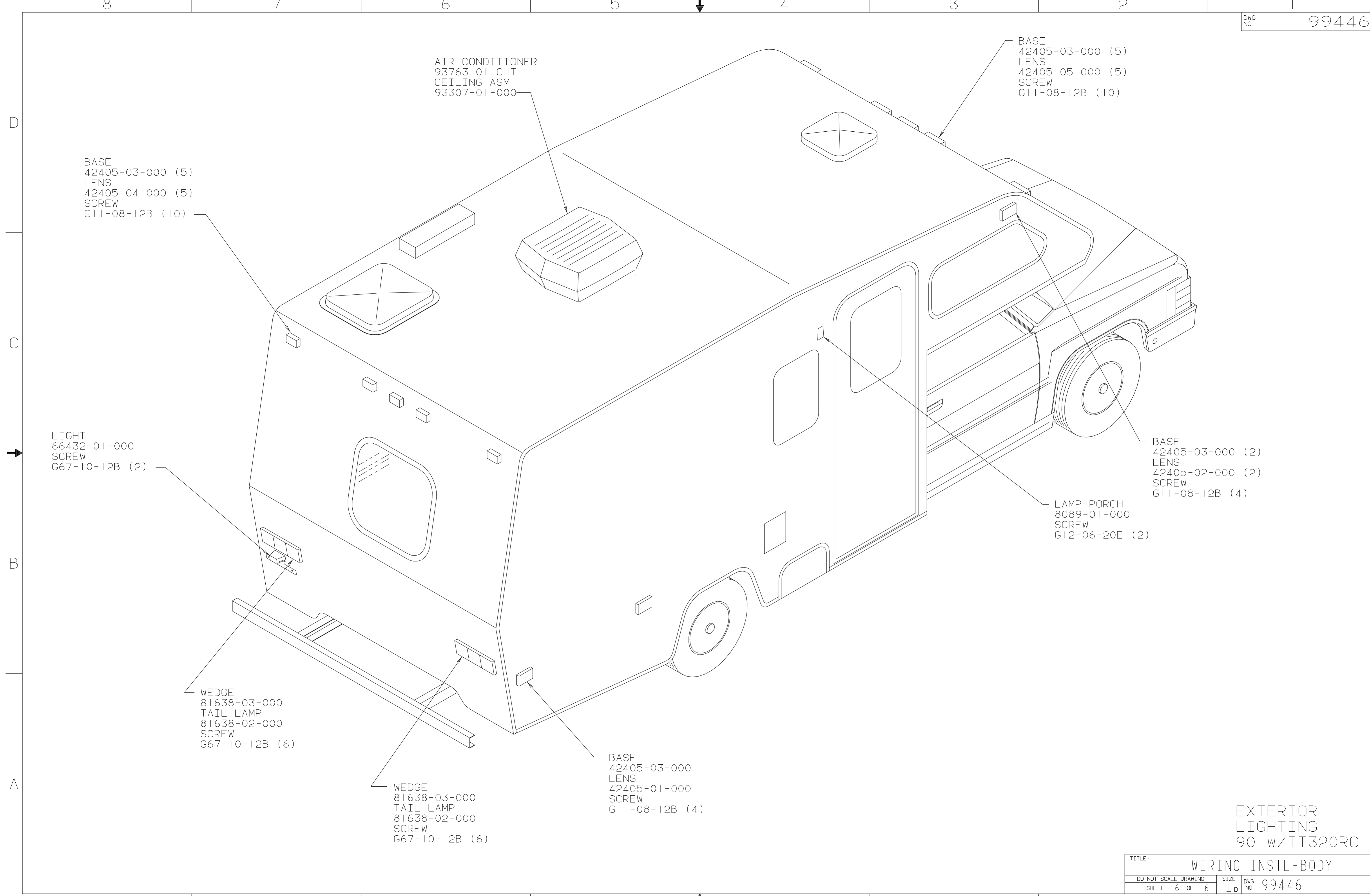

BASE
42405-03-000 (5)
LENS
42405-04-000 (5)
SCREW
G11-08-12B (10)

AIR CONDITIONER
93763-01-CHT
CEILING ASM
93307-01-000

BASE
42405-03-000 (5)
LENS
42405-05-000 (5)
SCREW
G11-08-12B (10)

LIGHT
66432-01-000
SCREW
G67-10-12B (2)

BASE
42405-03-000 (2)
LENS
42405-02-000 (2)
SCREW
G11-08-12B (4)

LAMP-PORCH
8089-01-000
SCREW
G12-06-20E (2)

WEDGE
81638-03-000
TAIL LAMP
81638-02-000
SCREW
G67-10-12B (6)

WEDGE
81638-03-000
TAIL LAMP
81638-02-000
SCREW
G67-10-12B (6)

BASE
42405-03-000
LENS
42405-01-000
SCREW
G11-08-12B (4)

EXTERIOR
LIGHTING
90 W/IT320RC

TITLE: WIRING INSTL-BODY	
DO NOT SCALE DRAWING	SIZE I.D.
SHEET 6 OF 6	DWG NO 99446