

- ▲ USE HOT MELT GUE 77029-01-000
- ▲ USE WIRE TIES 8343-01-000 TO CLAMP WIRES TO BRACKET, ROUTE UNDER CARPET
- ▲ USE WITH DRIVER DOOR
- 1 USE WIRE TIES 8344-01-000 AND CLAMPS 10497-01-000 APPROX 60 MM ON CENTER.

**WINNEBAGO**

DATE	REV	BY	CHKD
01/01/00	1	...	...
PL	DATE	BY	CHKD
...	...	...	...
DATE	REV	BY	CHKD
...	...	...	...
DATE	REV	BY	CHKD
...	...	...	...

ALL DIMENSIONS ARE IN MILLIMETERS

WIRING INSTL-FRONT END

REF B9350 1 96292

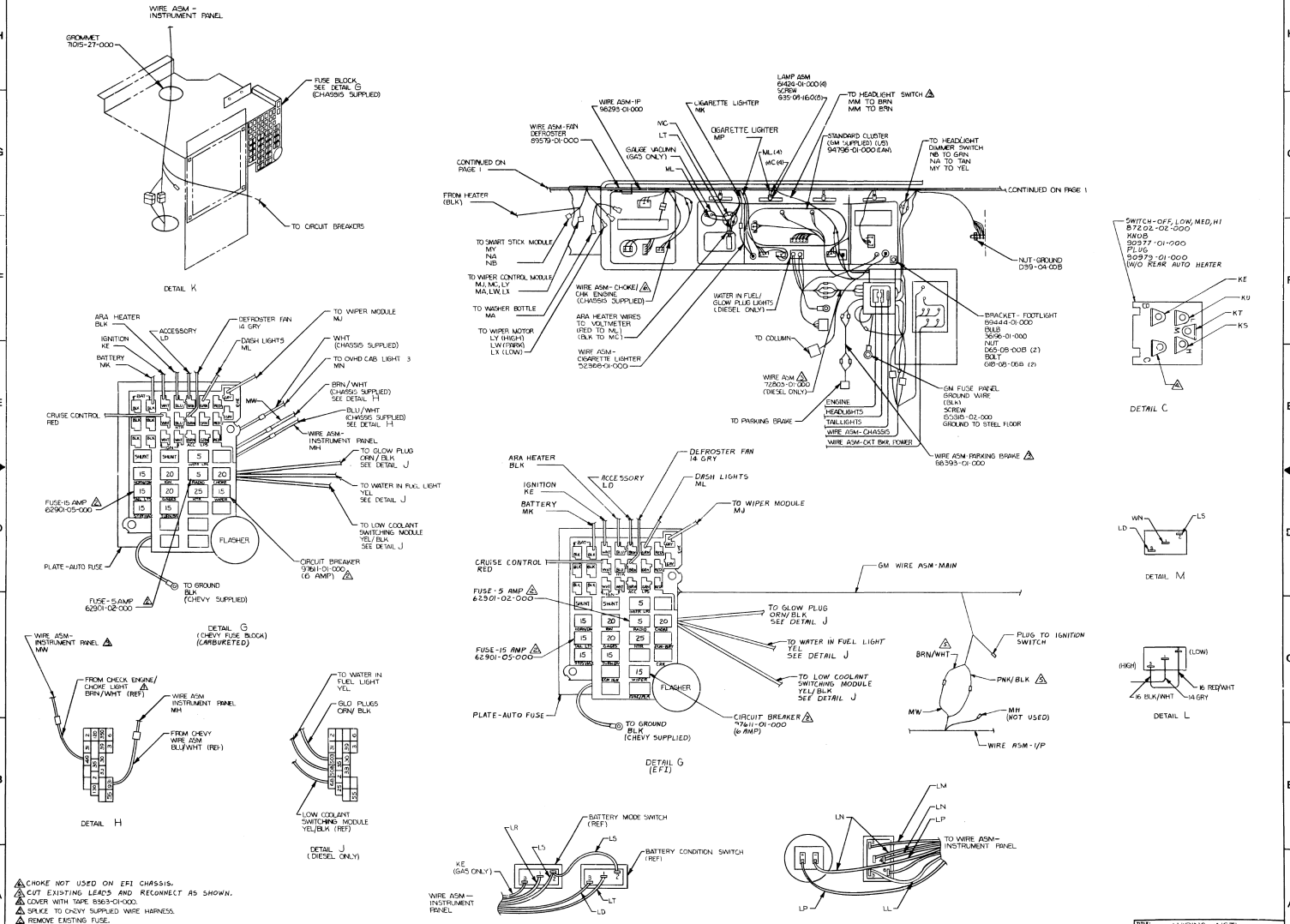

- NOTES:
- ▲ CHOKER NOT USED ON EPJ CHASSIS.
  - ▲ CUT EXISTING LEADS AND RECONNECT AS SHOWN.
  - ▲ COVER WITH TAPE 9563-CH-000.
  - ▲ SPLICE TO EXISTING SUPPLIED WIRE HARNESS.
  - ▲ REMOVE EXISTING FUSE.
  - ▲ REMOVE TERMINAL AND ISO WIRE, SPLICE TO WIRE ASM AS SHOWN.

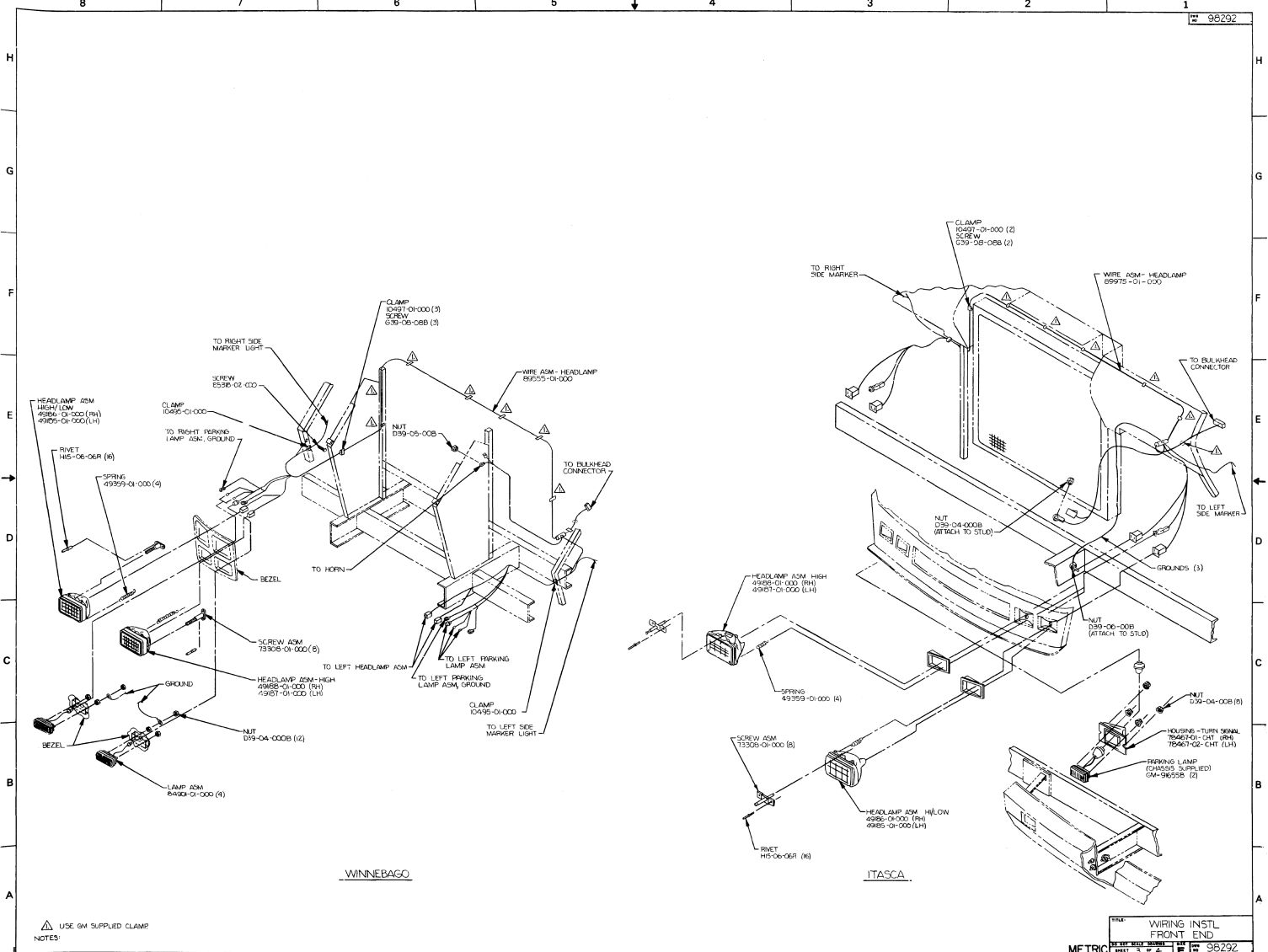

▲ USE GM SUPPLIED CLAMP  
NOTES

WIRING INSTL  
FRONT END

METRIC

98292

H

G

F

E

D

C

B

A

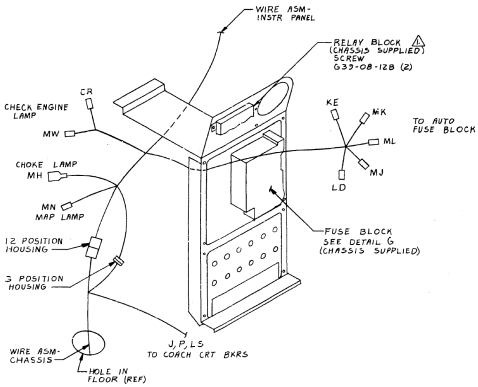

START 1990 CHASSIS.  
NOTES:

WIRING INSTL.  
FRONT END

METRIC

98292