

- RECP 79293-01-CHT BOX
- 58049-01-000 SCREW
- G11-08-20B(4)
- WIRE 60235-01-000 (200)
- TERMINAL 8328-01-000
- 532-10-06B BOX
- 93767-01-CHT SCREW
- G11-10-10U(4) CONNECTOR
- 8311-01-000(3)

- ④ SEAL WITH BEDDING COMPOUND 69639-01-000.
- ③ WIRE ROUTED IN FLOOR.
- ② COVER WITH CONDUIT 41953-01-000 IN THIS AREA.
- ① WIRE IN SIDEWALL.

NOTES:

RIGHT SIDE 110V (US) 90 W/ICN31RG

TITLE: WIRING INSTL-BODY	
30 NET SCALE DRAWING	FILE NO 97321
SHEET 2 OF 3	1 E

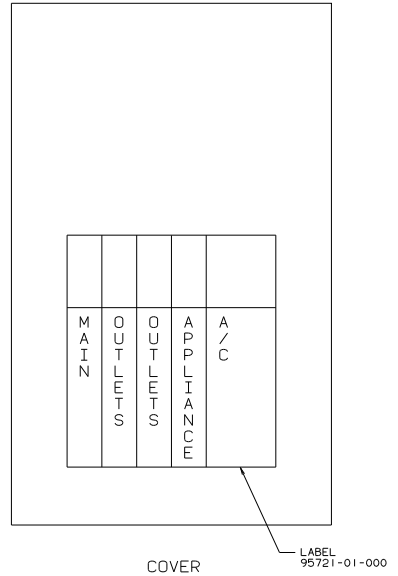
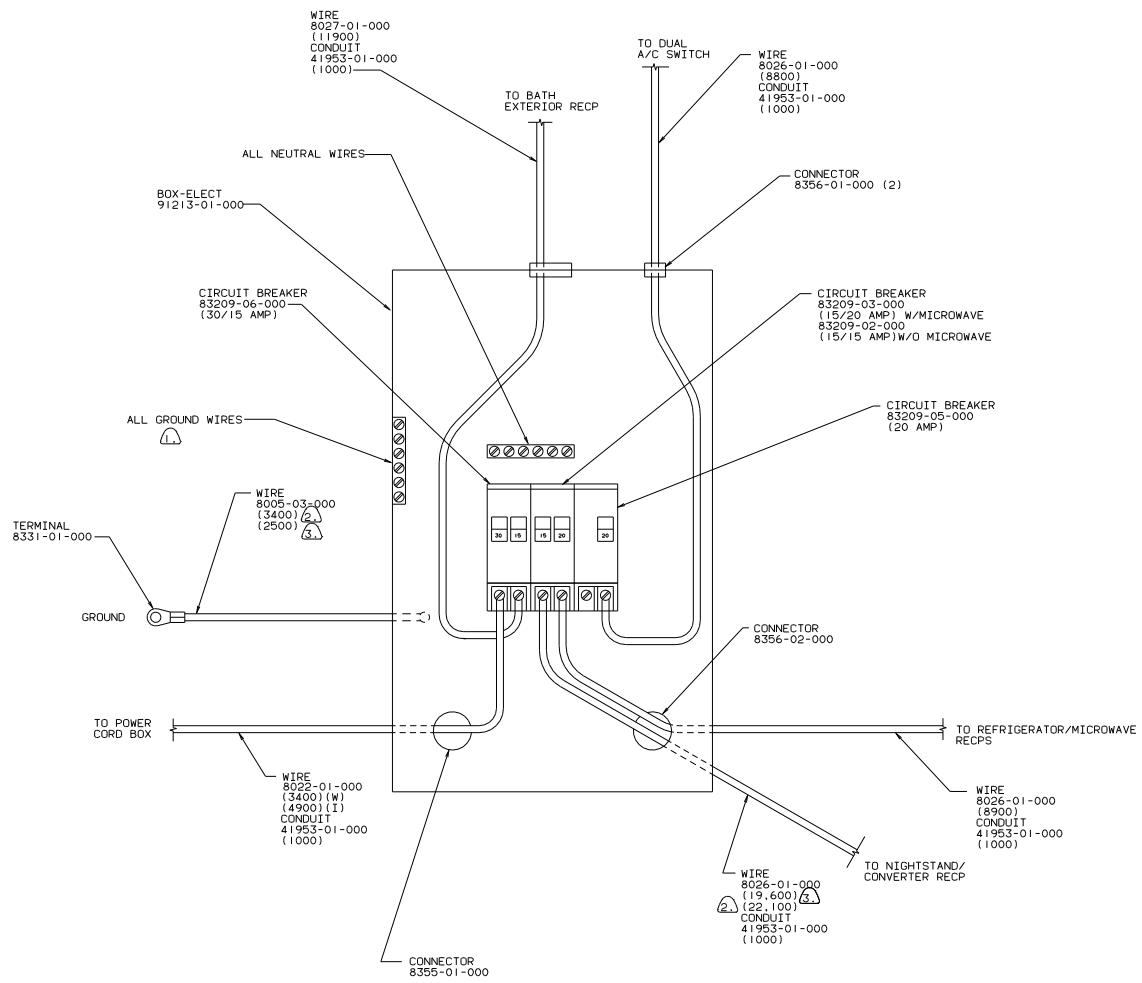

- NOTES:
- (3) USE WITH QUEEN BED ONLY.
 - (2) USE WITH TWIN BED ONLY.
 - (1) ALL GROUND WIRES TO BE COVERED WITH TUBING 8041-02-000.

CONTROL CENTER (US) 90 W/1CN31RD

TITLE: WIRING INSTL-BODY	
30 NET SCALE DRAWING	FILE NO
SHEET 3 OF 13	97321

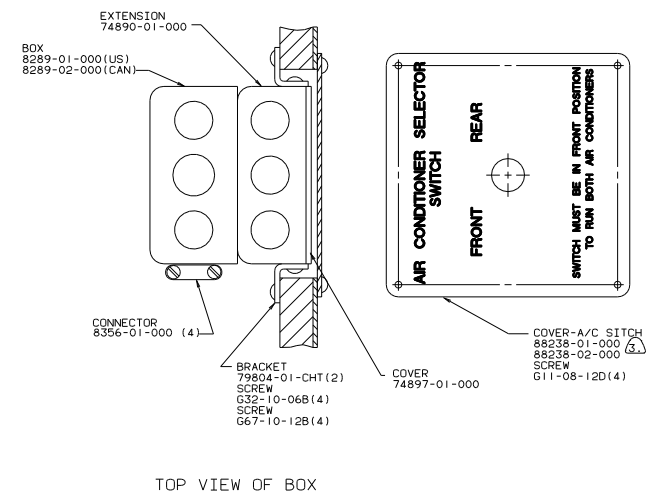
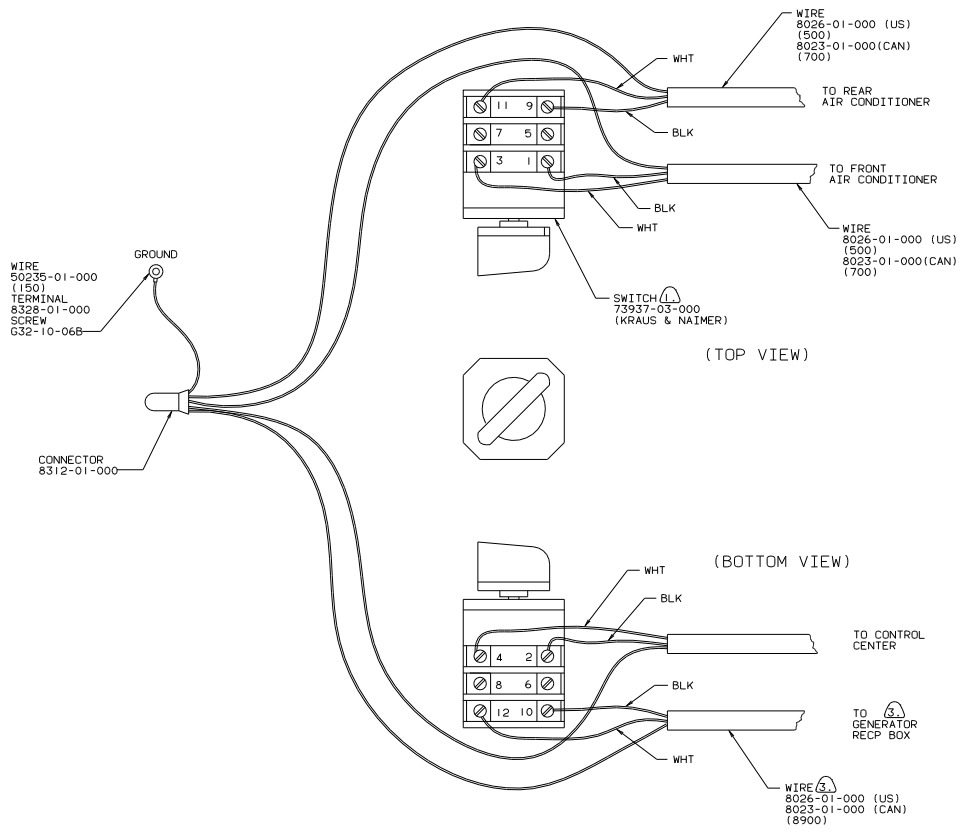

- NOTES:
- ③ USE WITH 6500 WATT GENERATOR OF LARGER.
 - ② ALL GROUND WIRES TO BE COVERED WITH TUBING 8041-02-000.
 - ① FASTEN SWITCH TO COVER 74897-01-000 BEFORE FASTENING COVER TO BOX.

DUAL AIR SWITCH
110 V (US/CAN)
90 W/ICN31RD

TITLE		97321	
WIRING INSTL-BODY (US)			
DO NOT SCALE DRAWING	SHEET	OF	TOTAL SHEETS
	4	13	13

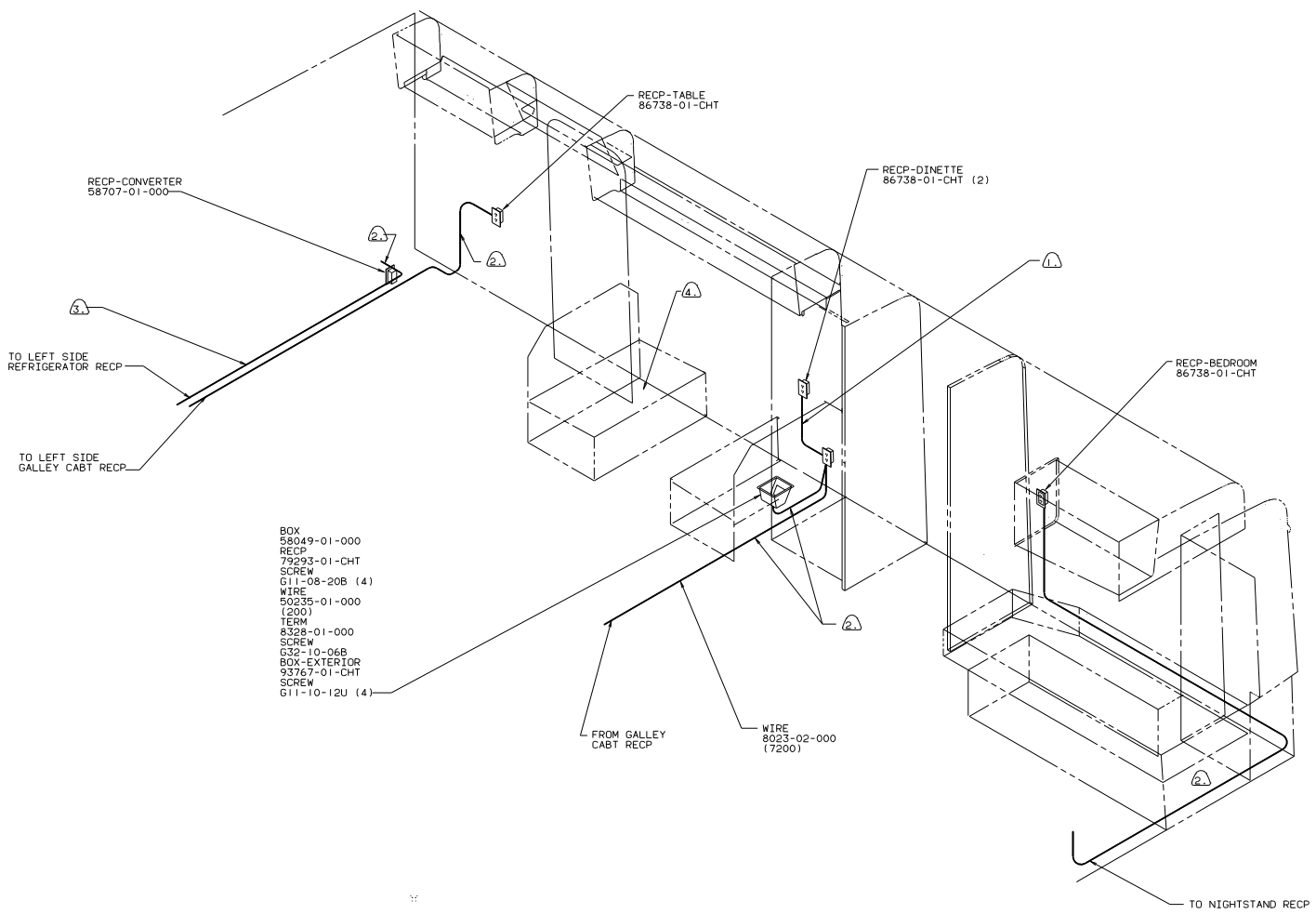

BOX
 58049-01-000
 RECP
 79293-01-CHT
 SCREW
 G11-08-20B (4)
 WIRE
 50235-01-000
 (200')
 TERM
 8328-01-000
 SCREW
 G32-10-06B
 BOX-EXTERIOR
 93767-01-CHT
 SCREW
 G11-10-12U (4)

- NOTES:
- ④ SEAL WITH BEDDING COMPOUND 69639-01-000.
 - ⑤ WIRE ROUTED IN FLOOR.
 - ② COVER WITH CONDUIT 41953-01-000 IN THIS AREA.
 - ① WIRE IN SIDEWALL.

RIGHT SIDE
 110V (CAN)
 90 W/ICN31RD

TITLE: WIRING INSTL-BODY	
30 NET SCALE DRAWING	FILE NO
SHEET 6 OF 13	97321

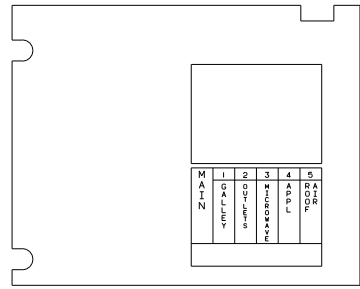
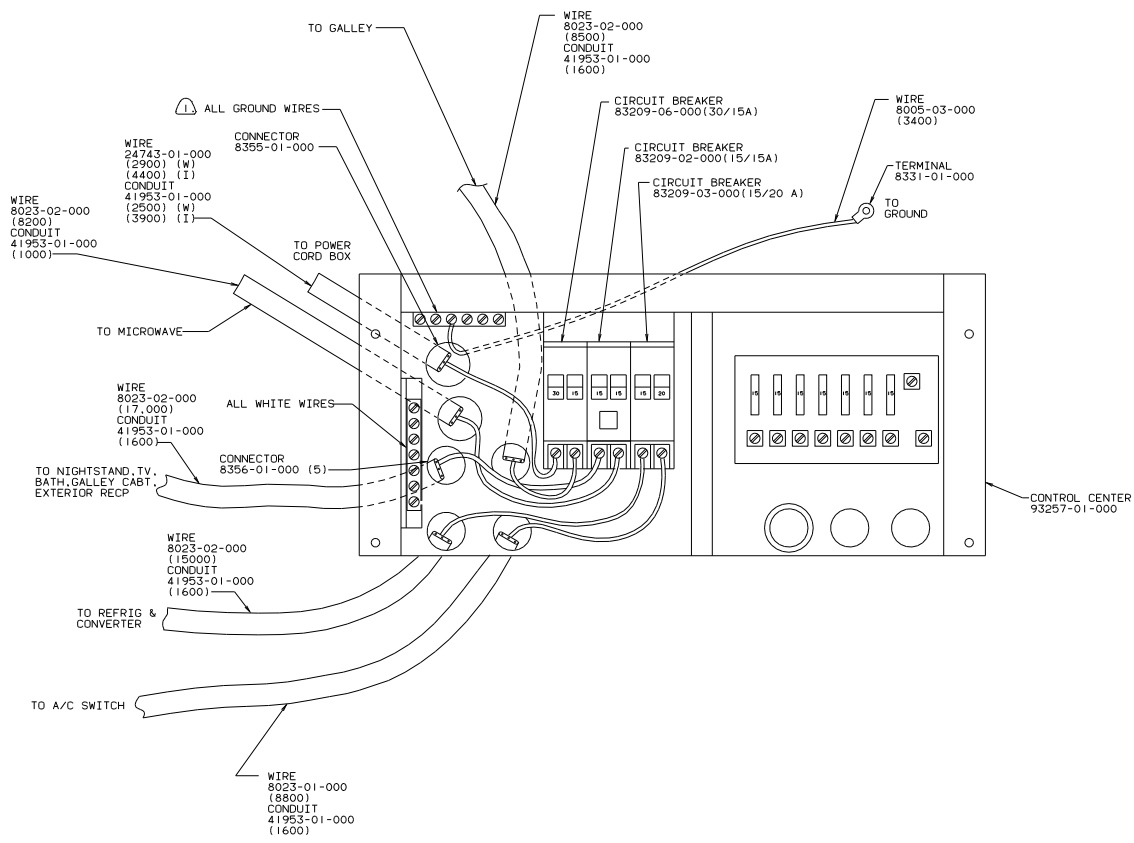

Ⓜ ALL GROUND WIRES TO BE COVERED WITH TUBING 8041-02-000.

CONTROL CENTER (CAN)
90 W/ICN31RD

TITLE		WIRING INSTL-BODY	
DO NOT SCALE DRAWING	SHEET	7	of 13
DATE	DESIGN NO	97321	

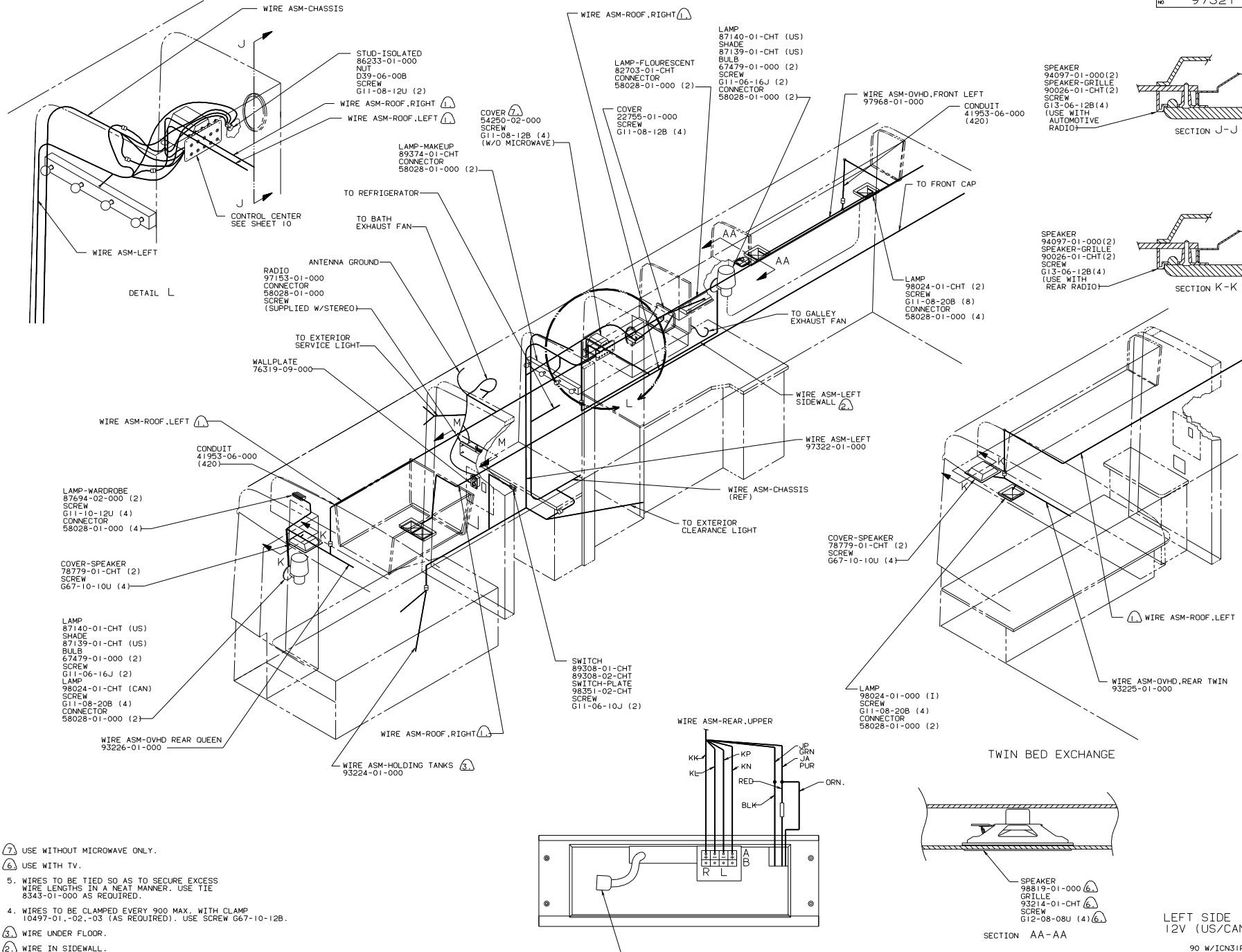

- 7 USE WITHOUT MICROWAVE ONLY.
- 6 USE WITH TV.
5. WIRES TO BE TIED SO AS TO SECURE EXCESS WIRE LENGTHS IN A NEAT MANNER. USE TIE 8343-01-000 AS REQUIRED.
4. WIRES TO BE CLAMPED EVERY 900 MAX. WITH CLAMP 10497-01-.02-.03 (AS REQUIRED). USE SCREW G67-10-12B.
- 3 WIRE UNDER FLOOR.
- 2 WIRE IN SIDEWALL.
- 1 WIRE IN ROOF.

NOTES:

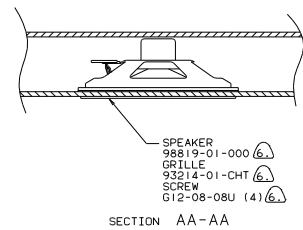
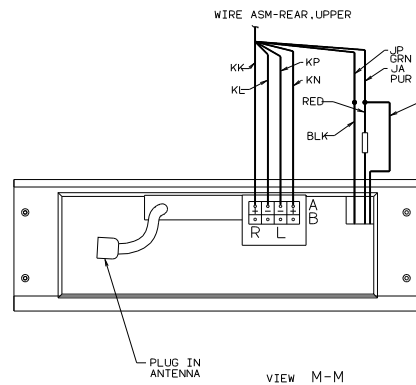

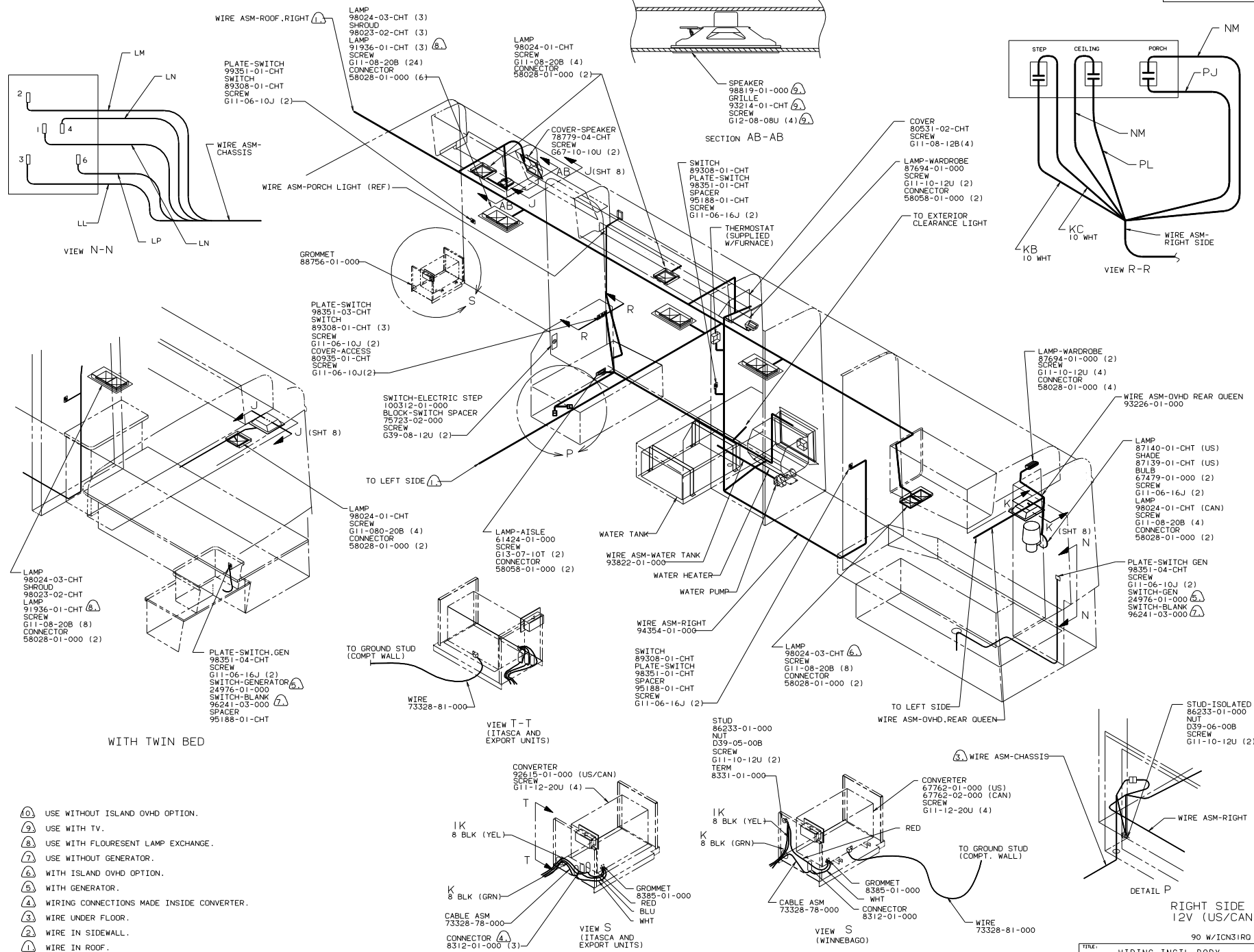

- NOTES:
- ⑩ USE WITHOUT ISLAND OVHD OPTION.
 - ⑨ USE WITH TV.
 - ⑧ USE WITH FLOURESENT LAMP EXCHANGE.
 - ⑦ USE WITHOUT GENERATOR.
 - ⑥ WITH ISLAND OVHD OPTION.
 - ⑤ WITH GENERATOR.
 - ④ WIRING CONNECTIONS MADE INSIDE CONVERTER.
 - ③ WIRE UNDER FLOOR.
 - ② WIRE IN SIDEWALL.
 - ① WIRE IN ROOF.

TITLE: WIRING INSTL-BODY		90 W/1CN31RD	
30 MIL SCALE DRAWING	SHEET 9 OF 13	DATE	97321

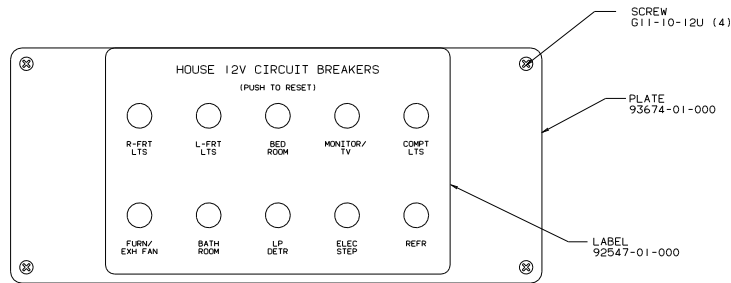

CIRCUIT BREAKER (FRONT VIEW)

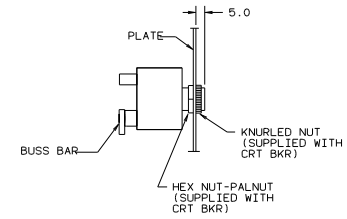

SECTION U-U

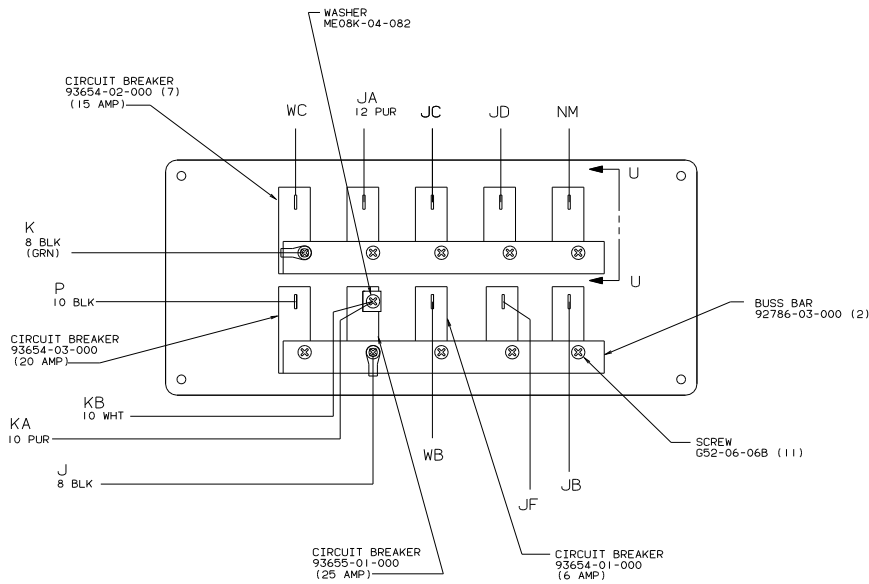

CIRCUIT BREAKER (W) (BACK VIEW)

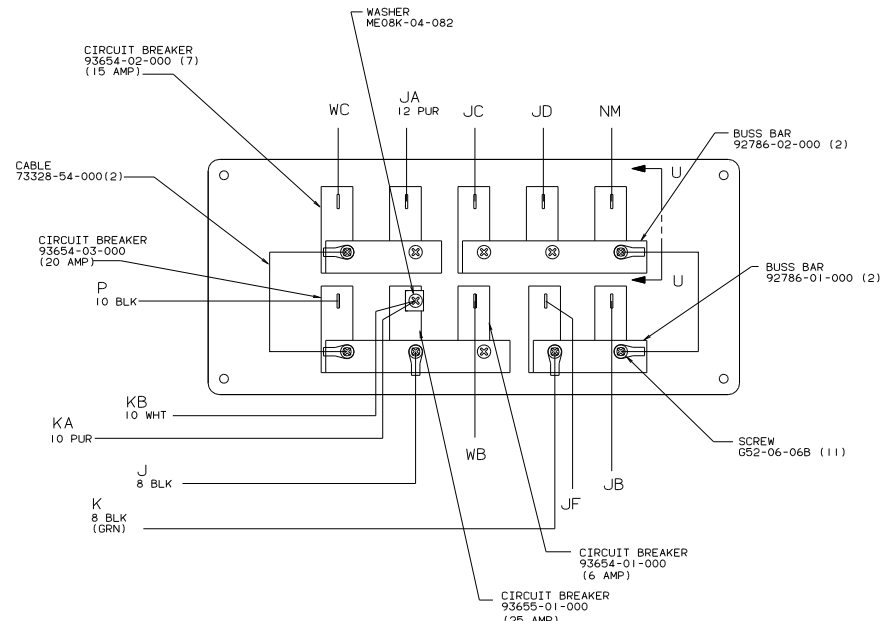

CIRCUIT BREAKER (I) (BACK VIEW)

12V CONTROL CENTER

90 W/1CN31R0

TITLE: WIRING INSTL-BODY	
30 NET SCALE DRAWING	FILE NO 97321
SHEET 10 OF 13	1 E

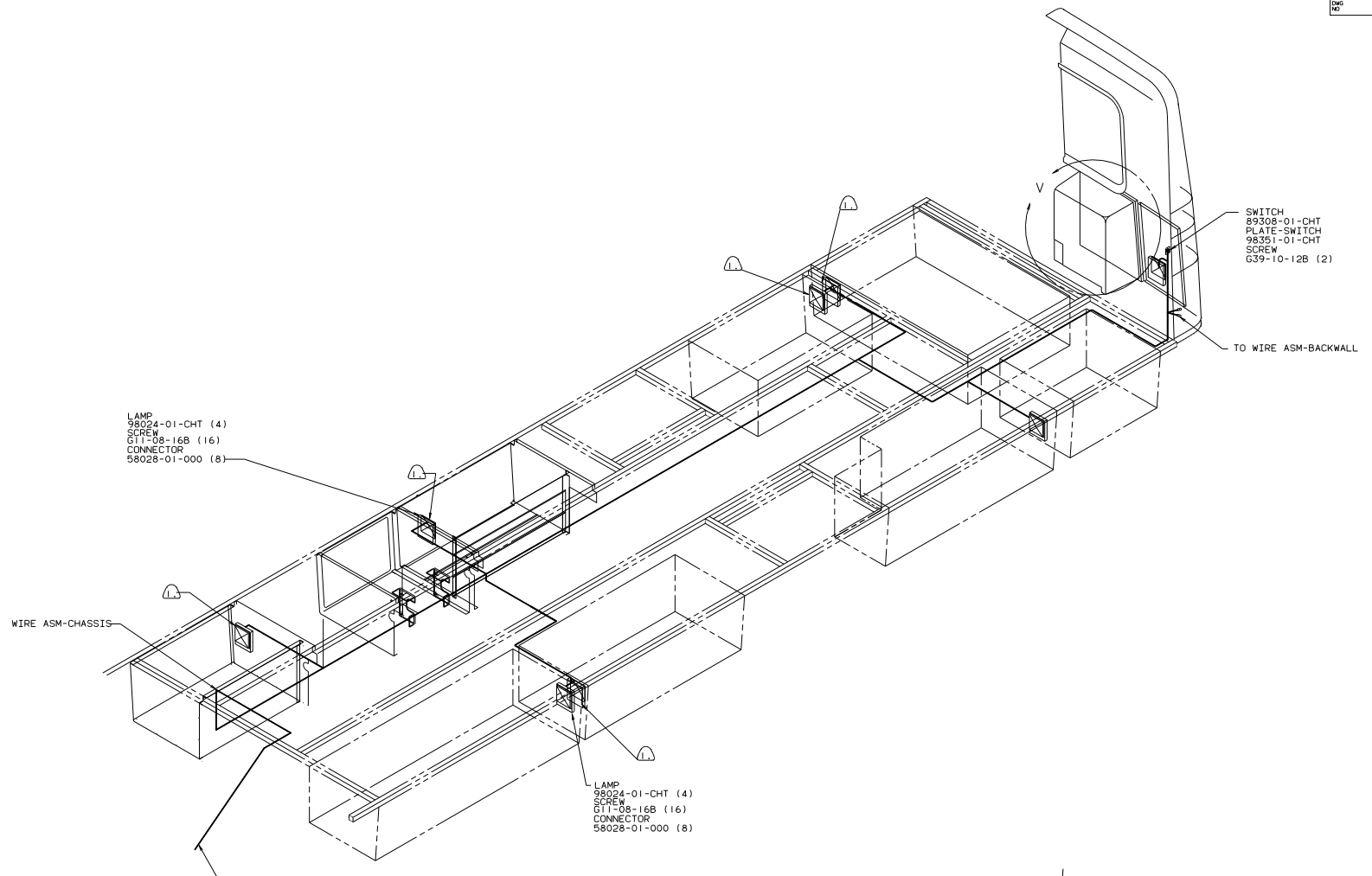

LAMP
98024-01-CHT (4)
SCREW
G11-08-16B (16)
CONNECTOR
58028-01-000 (8)

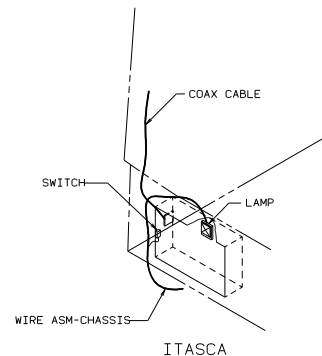
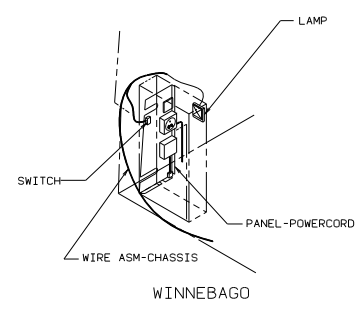

COMPARTMENT LAMP
90 W/ICN31RO

TITLE: WIRING INSTL-BODY	
30 NET SCALE DRAWING	FILE NO 97321
SHEET 11 OF 13	1 E

USE WITH WINNEBAGO.

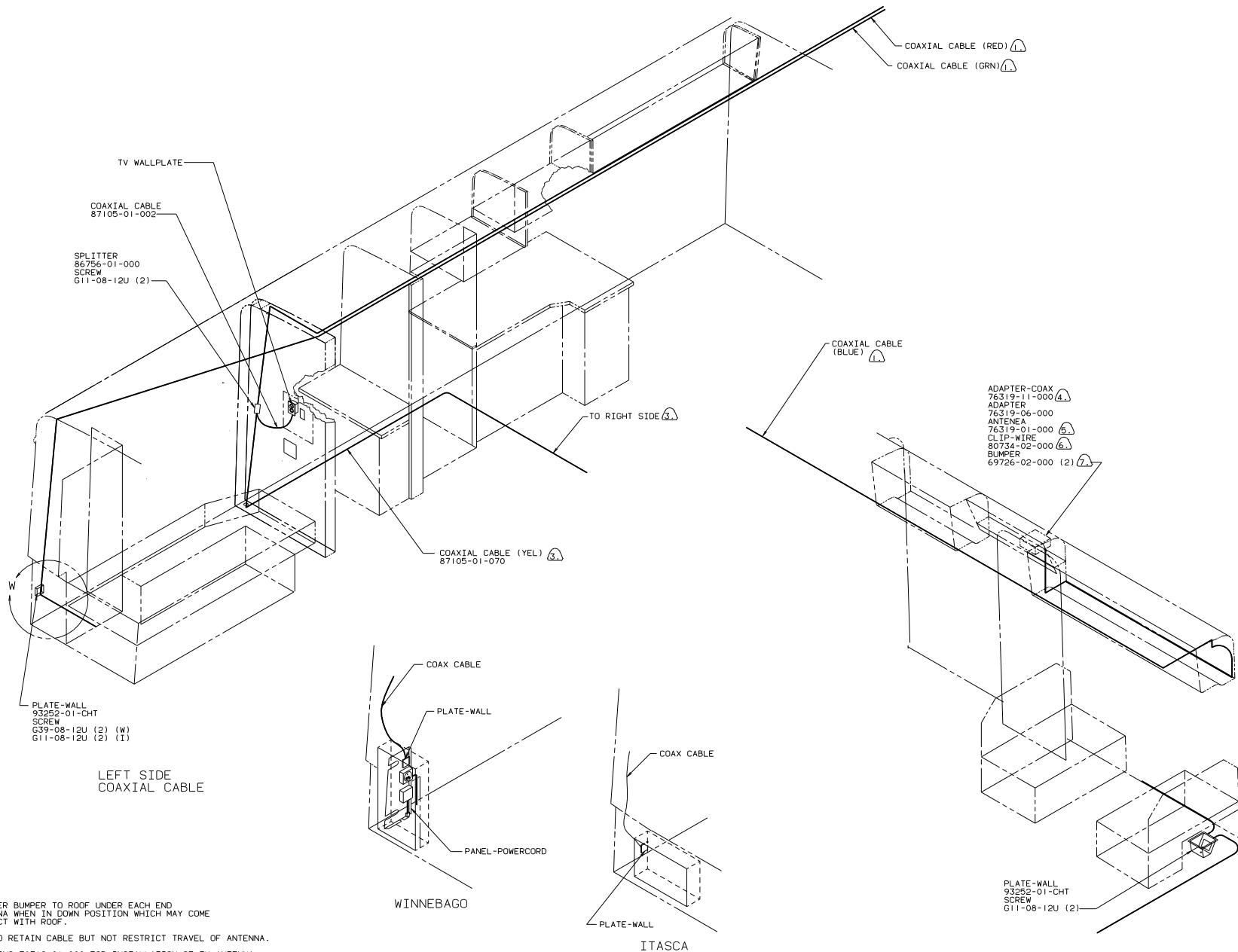

TV WALLPLATE
 COAXIAL CABLE
 87105-01-002

SPLITTER
 86706-01-000
 SCREW
 G11-08-12U (2)

PLATE-WALL
 93252-01-CHT
 SCREW
 G39-08-12U (2) (W)
 G11-08-12U (2) (I)

LEFT SIDE
 COAXIAL CABLE

COAXIAL CABLE (YEL)
 87105-01-070

COAXIAL CABLE (RED)
 COAXIAL CABLE (GRN)

COAXIAL CABLE
 (BLUE)

ADAPTER-COAX
 76319-11-000
 ADAPTER
 76319-06-000
 ANTENNA
 76319-01-000
 CLIP-WIRE
 80734-02-000
 BUMPER
 69726-02-000 (2)

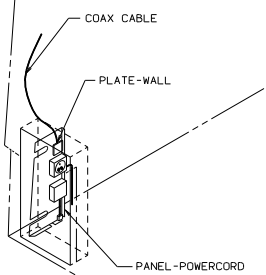

WINNEBAGO

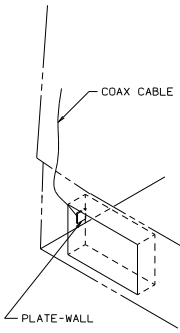

ITASCA

DETAIL W

PLATE-WALL
 93252-01-CHT
 SCREW
 G11-08-12U (2)

COAXIAL CABLE
 90 W/ICN31RD

- NOTES:
- 1 ADD RUBBER BUMPER TO ROOF UNDER EACH END OF ANTENNA WHEN IN DOWN POSITION WHICH MAY COME IN CONTACT WITH ROOF.
 - 2 LOCATE TO RETAIN CABLE BUT NOT RESTRICT TRAVEL OF ANTENNA.
 - 3 SEE DRAWING 76319-01-000 FOR INSTALLATION OF TV ANTENNA.
 - 4 ADAPTER-COAX SUPPLIED LOOSE IN VEHICLE.
 - 5 WIRE UNDER FLOOR.
 - 6 WIRE IN SIDEWALL.
 - 7 WIRE IN ROOF.

TITLE: WIRING INSTL-BODY	
30 NET SCALE DRAWING	FILE NO 97321
SHEET 12 OF 13	1/E

