

# "JOIN THE CLUB"...

## AND BE SOMEONE VERY SPECIAL!

As the proud owner of a Winnebago or Itasca brand motor home, you are eligible to belong to the Winnebago-Itasca Travelers Club (WIT). WIT offers the opportunity to share friendship and fun with people like yourself—special people—for whom travel and adventure have become a way of life...people who are drawn to the open road and the chance to explore the world around them.

### Come along to share the camaraderie and companionship

For many, the best thing about WIT is the goodwill and fellowship that develops among members of this exclusive club. There's something for everybody. Special groups exist within WIT for people with travel-related interests: Amateur Radio Club, the 365 Club (for members who spend 6 months of each year in their unit), Handicapped Club, Traveling Squares (for those who enjoy square dancing), WIT-LEO (for all present and former law enforcement officers) and Singles Club. Those who seek activity can play bingo, hike, pitch horseshoes and more. Those who wish to relax may just want to sit around the campfire swapping tales.

### No matter how frequently you travel, WIT can be of service

Whether you travel one weekend a month or every day of the year, you'll benefit from the many conveniences and services WIT offers: membership directory, monthly club magazine, KOA discount card, trip routing, 10% discount at Winnebago Customer Service on parts and catalog sales, opportunities to purchase personal RV insurance, long term convalescence care insurance, and merchandise, access to TTS (WIT's emergency road service), mail forwarding and more to come!

### We'll make all the plans for trips to near and far

As a WIT member, you'll be invited to attend local outings and state rallies. The Grand National Rally is held each year at Forest City, Iowa. For those on the move WIT sponsors a number of caravans and tours each year to exciting places. WIT members travel together in the comfort and convenience of their own motor homes, headed by profes-

sional tour directors who handle all the arrangements.

### WIT offers the first of its kind Emergency Road Service

WIT has joined with TTS, long known as the "AAA" of the trucking industry, to bring to the No. 1 Owners' Club the success and experience of the leader in the emergency road service. Fast service is provided from more than 7,000 locations nationwide including Canada and Alaska through a toll-free "800" phone service.

### Send in your application now and become a member of our exclusive club

Add to the enjoyment of your motor home and your leisure time by joining this friendly, active group. Simply fill out the application form and send it to us with your check or money order, or charge it to your VISA or MasterCard. Your name will be added to our list of very special people and you'll begin immediately to reap the benefits of membership in the Winnebago-Itasca Travelers Club.

## APPLICATION FOR MEMBERSHIP WINNEBAGO-ITASCA TRAVELERS

P.O. Box 268 Forest City, Iowa 50436 Phone: (515) 582-6874

(PLEASE PRINT)

Name \_\_\_\_\_

Companion's or Spouse's name \_\_\_\_\_

Address \_\_\_\_\_

City \_\_\_\_\_

State Iowa Zip 50436

Telephone: (\_\_\_\_) \_\_\_\_\_

METHOD OF PAYMENT

Personal check or money order

VISA

MasterCard

Card No.: \_\_\_\_\_

Expiration date: \_\_\_\_\_

Signature \_\_\_\_\_

Date \_\_\_\_\_

TYPE OF UNIT:

WIT must have coach serial number (begins with 10 or 70 and has 11 or 12 digits)

Serial No.: \_\_\_\_\_

Year \_\_\_\_\_

Model \_\_\_\_\_

NEW MEMBERSHIP

Dues of \$30 for 1 year

Dues of \$50 for 2 years

Dues of \$65 for 3 years

REINSTATEMENT OF WIT No. \_\_\_\_\_

Dues of \$25 for 1 year

Dues of \$45 for 2 years

Dues of \$60 for 3 years

MEMBERSHIP SPONSORED BY:

Name \_\_\_\_\_

WIT No. \_\_\_\_\_



## TO THE OWNER

Congratulations! We welcome you to the exciting world of motor home travel and camping. You will find it convenient and enjoyable to have all the comforts of home and still enjoy the great outdoors, wherever you choose to go.

Your motor home has been carefully designed, engineered and manufactured to provide dependability as well as safety. Before sliding into the driver's seat, take a few minutes to become familiar with operations and features. This manual was prepared to aid you in the proper care and operation of the vehicle and equipment. We urge you to read it completely. In addition, spend some time with the dealer when you take delivery, you will want to learn all you can about your new motor home.

Your Winnebago motor home is covered by a factory warranty against defects in material and workmanship. This warranty should be validated at once and returned to the factory by your dealer.

Throughout this manual, reference is made to the following terms: Important, Caution and Warning. These terms indicate important information which must be understood and followed. The definitions of these terms are:

### **IMPORTANT**

Indicates a special point of information.

### **CAUTION**

Indicates that a failure to observe can cause damage to equipment.

### **WARNING**

Indicates that failure to observe can cause personal injury or death and possible damage to equipment.

---

OWNER'S NAME

---

STREET ADDRESS

---

CITY AND STATE (OR PROVINCE IN CANADA)

---

MOTOR HOME SERIAL NUMBER

---

VEHICLE CHASSIS IDENTIFICATION NO. (VIN)

---

DATE OF DELIVERY TO FIRST RETAIL PURCHASER

---

VEHICLE MILEAGE AT TIME OF SUCH DELIVERY

---

SELLING DEALER NAME AND ADDRESS



## TABLE OF CONTENTS

### INTRODUCTION

Winnebago-Itasca Travelers Club (WIT) . . .	i
Operators Manual . . . . .	iv
Vehicle Chassis Manual . . . . .	iv
Motor Home Operations Manual (Binder) . . . . .	iv
Before Driving . . . . .	iv
Service Assistance . . . . .	v
Drinking and Driving . . . . .	v
Vehicle Certification Label . . . . .	vi
Exterior Feature Identification . . . . .	vii

### SECTION 1: SAFETY PRECAUTIONS

General Warnings . . . . .	1-1
Driving . . . . .	1-1
Fuel & LP Gas . . . . .	1-1
LP Gas Leaks . . . . .	1-2
LP Leak Gauge . . . . .	1-2
Electrical . . . . .	1-3
Loading . . . . .	1-3
Maintenance . . . . .	1-3
Formaldehyde Warning . . . . .	1-4
Carbon Monoxide Warning . . . . .	1-4
Emergency Exit Window . . . . .	1-5
Safety Devices	
Fire Extinguisher . . . . .	1-5
Smoke Detector . . . . .	1-5

### SECTION 2: DRIVING YOUR MOTOR HOME

Before Entering . . . . .	2-1
Before Driving . . . . .	2-2
Keys . . . . .	2-2
Fuel Selection . . . . .	2-2
Gasoline Fuel Fill . . . . .	2-2
Starting and Stopping Engine . . . . .	2-2
Parking Brake . . . . .	2-2
Hazard Warning Lights . . . . .	2-3
Fuel Pump Shut-Off Switch . . . . .	2-3
Door Locks and Handles . . . . .	2-3
Entrance Step . . . . .	2-4
Seats . . . . .	2-5
Seat Belts . . . . .	2-6
Child Restraints . . . . .	2-7
Mirrors . . . . .	2-7
Rear Vision Camera/Monitor System . . . . .	2-8
Instrument Panel . . . . .	2-9
Electronic Instrument Panel . . . . .	2-16
Windshield Wiper/Washer Switch . . . . .	2-17
Speed Control (Cruise) . . . . .	2-17
Rear Window Wiper . . . . .	2-19
Comfort Controls . . . . .	2-19
Heating . . . . .	2-19
Defrosting . . . . .	2-20
Ventilation . . . . .	2-20
Air Conditioning . . . . .	2-20
Rear Auto Heater . . . . .	2-20
Audio Entertainment System . . . . .	2-20
Radio Switch . . . . .	2-20
Vacuum-Fuel Economy Gauge . . . . .	2-21
Battery Condition Meter and Switch . . . . .	2-21
Battery Mode Switch . . . . .	2-21

Auxiliary Battery Switch . . . . .	2-21
Auxiliary Generator Switch . . . . .	2-21
Auxiliary Generator Hourmeter . . . . .	2-21
Map Light . . . . .	2-21
Beverage Tray Light . . . . .	2-21
Courtesy Lights . . . . .	2-21
Aisle Floor Light Switch . . . . .	2-22
Auxiliary Fan Switch . . . . .	2-22
ICC Courtesy Blink Switch . . . . .	2-22
Air Horns . . . . .	2-22
Coach Leveling Systems . . . . .	2-22

### SECTION 3: IN CASE OF DRIVING

#### EMERGENCY

Hazard Flashers . . . . .	3-1
Spare Tire . . . . .	3-1
Tire Changing	
Safety Precautions . . . . .	3-2
Front Wheel . . . . .	3-2
Dual Rear Wheels . . . . .	3-2
Recovery Towing . . . . .	3-3
Jump Starting . . . . .	3-4
Connecting a Battery Charger . . . . .	3-5
Engine Overheat . . . . .	3-6

### SECTION 4: TRAVELING WITH YOUR MOTOR HOME

Loading the Vehicle . . . . .	4-1
Roof Loading . . . . .	4-1
Trailer Towing . . . . .	4-1
Pre-Travel Checklist . . . . .	4-2
Equipping For Travel	
Emergency Equipment Checklist . . . . .	4-3
Quick Loading Checklist . . . . .	4-3
Travel Tips . . . . .	4-3
Severe Weather Information . . . . .	4-4
Nighttime Driving . . . . .	4-5
Mountain Driving . . . . .	4-5

### SECTION 5: LP GAS SYSTEM

LP Gas Supply . . . . .	5-1
Safe Use of LP Gas System . . . . .	5-1
How LP Gas Works . . . . .	5-1
Selecting Fuel Types . . . . .	5-1
Bulk Tank System . . . . .	5-2
Refilling Tank . . . . .	5-2
Air in the LP Gas Tank . . . . .	5-2
Traveling with LP Gas . . . . .	5-2
Regulator . . . . .	5-3
LP Gas Leaks . . . . .	5-4
LP Leak Gauge . . . . .	5-4
Winter Use of LP Gas . . . . .	5-5

### SECTION 6: ELECTRICAL SYSTEMS

110-Volt AC System . . . . .	6-1
External Power Cord (Shoreline Cord) . . . . .	6-1
Power Control Center (Converter) . . . . .	6-2
Converter and Circuit Breaker Locations	
Chieftain and Sunflyer . . . . .	6-2
Superchief and Suncruiser . . . . .	6-2
Charging Section . . . . .	6-3
Thermal Breaker . . . . .	6-3

110-Volt Circuit Breakers	6-3
110-Volt Receptacles (Outlets)	6-3
Ground Fault Circuit Interrupter (GFCI)	6-4
Auxiliary 110-Volt Generator Operating Instructions	6-4
12-Volt DC System	6-5
12-Volt Fuses and Circuit Breakers	6-6
Auxiliary (Coach) Battery	6-6
Coach Battery Locations	
Superchief and Suncruiser	6-7
Warrior and Spirit (A-Bodies)	6-7
All C-Body Models (Except 427RT)	6-7
Battery Maintenance	6-7
Battery Condition Meter and Switch	6-8
Battery Mode Switch (Except 319RB)	6-8
Auxiliary Battery Disconnect Switch	6-9
Drained Auxiliary Batteries	6-9
Battery Isolator (Diesel Vehicles)	6-9

### SECTION 7: PLUMBING SYSTEMS

Fresh Water System	7-1
Filling Water Tank	7-1
Draining the Tank	7-1
Seasonal Storing and Sanitizing the Water Tank	7-2
Water Pump	7-2
Water Pump Switch	7-2
Disinfection of Water Tank	7-2
External (City Water) Connector	7-3
Flushing External Water Hook-Up	7-3
Water Tank Power Drain	7-4
Shower Valve Pressure Bleed-Off	7-4
Drainage System (Waste)	7-4
Dumping Holding Tanks	7-4
Using On-Site Sewer Hook-Ups	7-5
Holding Tank Level Indicators	7-5
Water System Drain Valve Locations	7-5

### SECTION 8: APPLIANCES

Refrigerator	8-1
Range and Oven	8-6
Lighting Oven Pilot	8-7
Microwave Oven	8-8
Monitor Panel	8-8
Water Heater	8-9
LP Gas Furnace	8-11
Roof Air Conditioner	8-11
TV Antenna	8-11
TV Signal Amplifier	8-12

### SECTION 9: INTERIOR FEATURES AND FURNISHINGS

SLEEPING FACILITIES	
Front Pull-Down Bunk (A-Body)	9-1
Overhead Bunk (C-Body)	9-1
Couch/Bed Conversions	9-1
Dinette/Bed Conversion	9-1
Fold-Up Lavatory Sink	9-2
Fresh Water Toilet	9-2
Power Roof Vent	9-3
Crank-Out Windows	9-4

### SECTION 10: CARE AND MAINTENANCE

Roof	10-1
Underbody	10-1
Exterior	10-1
Interior Maintenance	
Upholstery, Carpeting and Draperies	10-1
Cabinets	10-2
Tables and Countertops	10-2
Stainless Steel Sink	10-2
Range and Refrigerator	10-2
Flooring	10-3
Bathroom	10-3
Washerless Faucet O-Rings	10-3
Doors and Windows	10-3
Roll-Up Window Shade Adjustment	10-3
Pleated Window Shade Adjustment	10-3
Vehicle Maintenance	
Chassis Service and Maintenance	10-4
Engine Access	10-4
Engine Cooling System	10-4
Tires	10-4
Suspension Alignment and Tire Balance	
Balance	10-4
Care of Optional Aluminum Wheels	10-5
Rear Air Springs	10-5
Rear Suspension Information	10-5
Windshield Washers and Wipers	10-6
Color-Keyed Bumper Shells	10-6
Lights	10-6
Automotive 12-Volt Fuses	10-6

### SECTION 11: STORING AND WINTERIZING

Preparing Vehicle For Storage	11-1
Cold Weather Storage	11-1
Removal From Storage	11-3

# INTRODUCTION

Congratulations on the purchase of your new motor home, which has been carefully designed, engineered and quality built by Winnebago Industries, Inc.

## Operator's Manual

Please read this operator's manual thoroughly. It was prepared in order to provide you with information necessary to properly and safely operate your new motor home.

This manual describes those instruments, controls and instructions which are unique to Winnebago and Itasca motor homes. For information regarding all other equipment, controls and instructions not described herein, we urge you to read the "Vehicle Chassis Manual" and the equipment manufacturer's information provided in your "Motor Home Operation Manual."

This manual should be kept in the vehicle at all times for personal reference. The operator's manual, motor home operation manual and vehicle chassis manual are to be considered permanent components of this vehicle. They should remain in the vehicle when sold to provide the next owner with important safety, operating and maintenance information.

**NOTE:** The descriptions, illustrations, and specifications in this manual were correct at the time of printing. We reserve the right to change specifications or design without notice, and without incurring obligation to install the same on products previously manufactured.

## Vehicle Chassis Manual

Throughout this manual, frequent reference is made to the vehicle chassis manual. The chassis manual is the operator's manual provided by the manufacturer of the chassis on which this motor home is built (i.e., Chevrolet, Ford, etc.). Consult the chassis manual for operating safety and maintenance instructions pertaining to the chassis section of the motor home.

## Motor Home Operation Manual (Binder)

Your Motor Home Operation Manual contains information supplied by manufacturers of individual appliances and equipment installed in your motor home.

Consult this information regarding the operation and care of appliances, accessories and special equipment.

## Options and Equipment

Since Winnebago and Itasca motor homes are available in many models and sizes, accessories and components may differ between models. Therefore, some equipment described in this manual may not apply to your vehicle.

## Before Driving

Before entering the driver's seat, always check around your vehicle in all directions to assure that you have proper clearance in order to avoid minor accidents. When backing up, be positive there is nothing behind your vehicle. As an extra precaution, have a passenger check the area around your vehicle as you maneuver out of a difficult parking space.

Even though your motor home has been equipped with automotive features such as power steering and power brakes, driving a motor home requires a somewhat different handling technique than driving an automobile. When driving your motor home, always remember that the weight, length, width and height are greater than that of an automobile. A motor home requires greater stopping distance, more parking space, more maneuvering space and more acceleration time when passing other vehicles than does an automobile.

Always be aware of the dimensions of your motor home. Tunnels, low hanging canopies and signs in service stations and restaurants can cause clearance problems. Keep in mind the added height of any options on the roof such as air conditioner units, TV antennas or luggage boxes. Also, remember that certain bridges, old ones in particular, may not accept the weight of your motor home. Always observe any posted weight limits.

When planning a trip to another state, write to the Chamber of Commerce of the state capital for information on state laws pertaining to RV's.

Remember: Always use your seat belt and instruct your passengers to do so as well. Frequent rest stops while traveling are advised to relieve stress on the driver, passengers and the vehicle.

### **Service and Assistance**

Your dealer will be glad to provide any additional information you need, as well as answer any questions you might have about operating the equipment in your motor home. When it comes to service, remember that your dealer knows your vehicle best and is interested in your satisfaction. Your dealer will provide quality maintenance and any other assistance that you may require during your ownership of the vehicle.

If you need warranty repairs while traveling, you may take your motor home to any Winnebago or Itasca dealership and they will assist you.

### **Warranty**

Your new vehicle is covered by a factory warranty against defects in material and workmanship. This warranty should be validated immediately and returned to the factory by your dealer. For additional information, see your "New Vehicle Limited Warranty" included with this vehicle.

### **DRINKING AND DRIVING**

Winnebago Industries supports the recommendations of the Presidential Commission on Drunk Driving.

- Exercise your good judgement and encourage others to do the same.
- Know the legal limits and do not exceed them.
- Also know your personal limits, which may be lower than the legal limits.
- Should you ever exceed your limits, find alternative transportation; call a cab, ask a friend to drive you home or call a family member to come and get you.

The presence of alcohol in significant levels in the blood increases the probability that the driver will be involved in an accident.

## VEHICLE CERTIFICATION LABEL

This label contains vehicle identification and other important reference information. On A-body motor homes, the vehicle certification label is located on the sidewall to the left of the steering wheel, or on the driver's door. On C-body motor homes, the label is attached to the lower area of the driver's door latch post. Never remove or destroy this label.

MANUFACTURED BY <b>WINNEBAGO</b> <sup>®</sup> Winnebago Industries, Inc.		INCOMPLETE VEHICLE MANUFACTURED BY <b>1</b> MOTORS CORP.	
<b>3</b>	MONTH AND YEAR OF MANUFACTURE: <b>2</b>		
	GVWR <b>4</b> LB. _____ KG		
GAWR:		SUITABLE TIRE AND RIM CHOICE	COLD INFLATION PRESSURE
FRT.	LB _____ KG _____	TIRE _____	PSI _____ K Pa _____
INT.	<b>5</b> LB _____ KG _____	<b>6</b> _____	<b>8</b> PSI _____ K Pa _____
RR.	LB _____ KG _____	<b>7</b> _____	PSI _____ K Pa _____
THIS VEHICLE CONFORMS TO ALL APPLICABLE FEDERAL MOTOR VEHICLE SAFETY STANDARDS IN EFFECT ON THE DATE OF MANUFACTURE SHOWN ABOVE.			
SERIAL NO. <b>10</b> _____		VIN <b>11</b> _____	
TYPE <b>12</b> _____		MODEL <b>13</b> _____ COLOR <b>14</b> _____	

### Explanation of Data

1. Chassis manufacturer.
2. Chassis manufacture date.
3. Month and year of manufacture at Winnebago Industries.
4. Gross Vehicle Weight Rating: Total permissible weight of the vehicle, including driver, passengers, total cargo carried (including all liquids) and equipped with all options.
5. Gross Axle Weight Rating: Total permissible weight allowed for the front, intermediate\* and rear axles (listed in pounds and kilograms).
6. Suitable Tire Choice: Tires recommended to meet handling and safety requirements. When replacing any of the tires on your vehicle, always replace with a tire that meets these specifications.
7. Suitable Rim Choice: Wheel rims recommended to meet handling and safety requirements. When replacing any rim, always replace with a rim that meets these specifications.
8. Cold Inflation Pressure: Inflation pressures recommended (while cold) for the tires originally equipped on your vehicle. These pressure levels must be maintained to assure proper handling, safety and fuel economy.
9. Intermediate\* and Rear Axle Wheel Configuration: Single or Dual.
10. Serial Number: This is the serial number assigned to the completed vehicle by Winnebago Industries.
11. Vehicle Identification Number (VIN): This number identifies the chassis on which the motor home is built.
12. Type: States the NHTSA designated usage classification for your motor home. MPV signifies a Multi-Purpose Vehicle.
13. Model: Lists the Winnebago product model number of your vehicle.
14. Color: Signifies the color code number of the decor used throughout the vehicle. This number is necessary for ordering replacement cushions, curtains, carpet, etc.

\*Intermediate (INT) data applies only to models equipped with tag axle.

## EXTERIOR FEATURE IDENTIFICATION - C-Body Motor Homes

Vehicle shown for illustration purposes only. Actual locations of features depends on model and option combinations

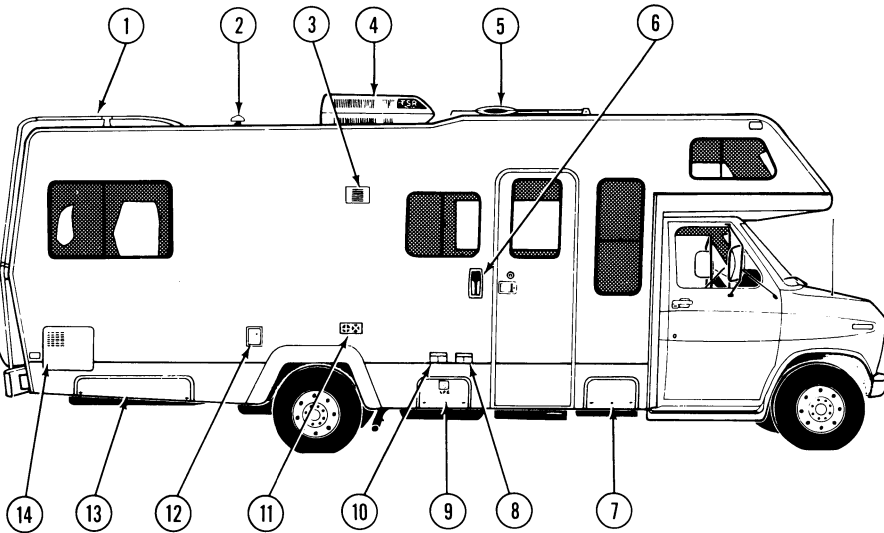

- |                         |                                  |                            |
|-------------------------|----------------------------------|----------------------------|
| 1. Roof Rack & Ladder   | 6. Assist Handle/Porch Light     | 11. Furnace Intake/Exhaust |
| 2. Plumbing Vent        | 7. Auxiliary Battery Compartment | 12. Water Tank Fill Access |
| 3. Range Hood Vent      | 8. 110-Volt Receptacle           | 13. Storage Compartment    |
| 4. Roof Air Conditioner | 9. LP Gas Tank Access            | 14. Water Heater Access    |
| 5. TV Antenna           | 10. Cable TV Connection          |                            |

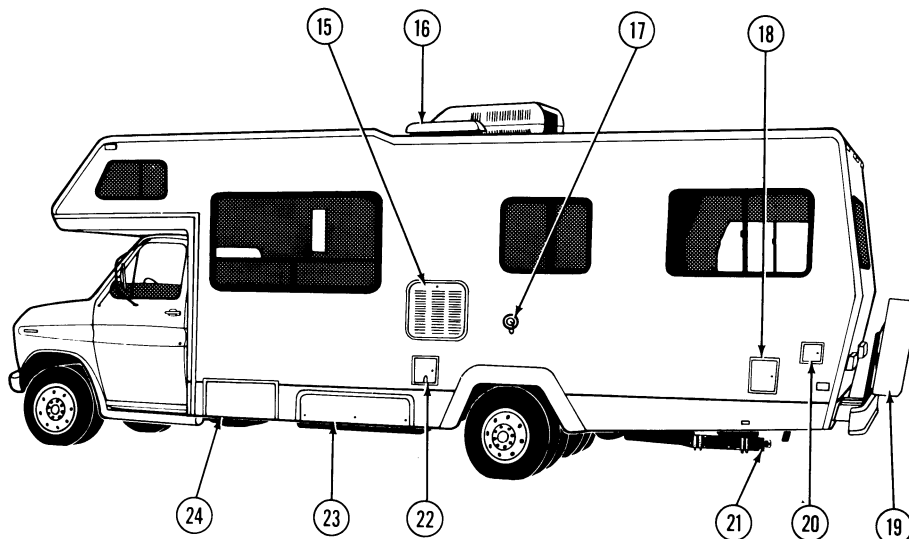

- |                           |                              |                                     |
|---------------------------|------------------------------|-------------------------------------|
| 15. Refrigerator Access   | 19. Spare Tire Storage       | 22. Utility Cord Compartment        |
| 16. Refrigerator Vent     | 20. Water Drain Hose Storage | 23. Storage Compartment             |
| 17. City Water Connection | 21. Water Drain Valve(s)     | 24. Auxiliary Generator Compartment |
| 18. Fuel Fill Access      |                              |                                     |

## EXTERIOR FEATURE IDENTIFICATION - A-Body Motor Homes

Vehicle shown for illustration purposes only. Actual locations of features depends on model and option combinations

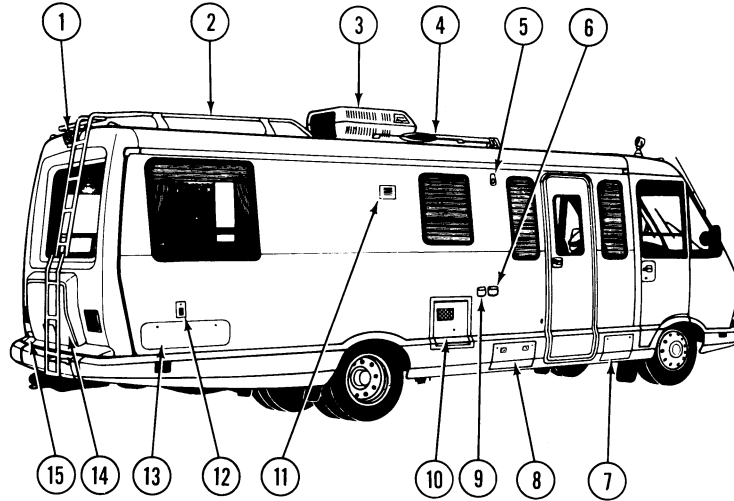

- |                         |                         |                                |
|-------------------------|-------------------------|--------------------------------|
| 1. Rear Monitor Camera  | 6. 110-Volt Receptacle  | 11. Range Hood Vent            |
| 2. Roof Rack & Ladder   | 7. Storage Compartment  | 12. Water Tank Fill Access     |
| 3. Roof Air Conditioner | 8. LP Gas Tank Access   | 13. Storage Compartment        |
| 4. TV Antenna           | 9. Cable TV Connection  | 14. Spare Tire Storage (Trunk) |
| 5. Porch Light          | 10. Water Heater Access | 15. Waste Drain Hose Storage   |

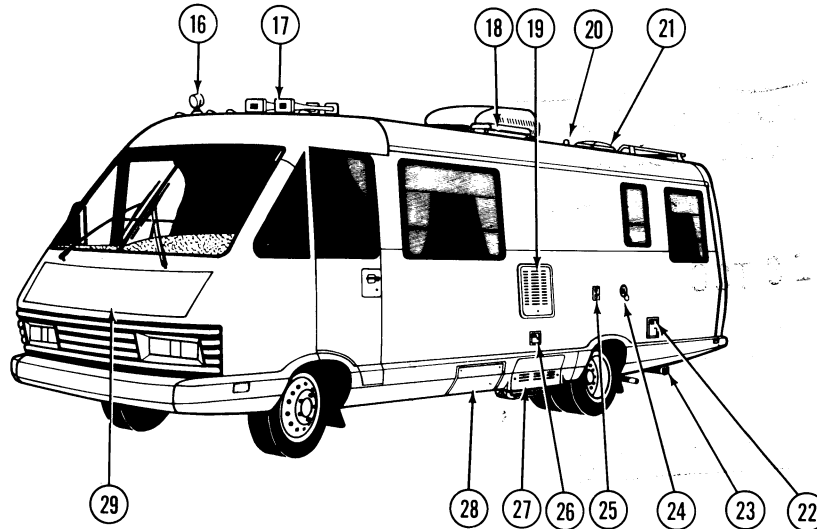

- |                             |                            |                                |
|-----------------------------|----------------------------|--------------------------------|
| 16. Remote Flood/Spot Light | 21. Roof Vent/Skylight     | 26. Utility Cord Compartment   |
| 17. Air Horns               | 22. Fuel Fill              | 27. Auxiliary Generator Access |
| 18. Refrigerator Vent       | 23. Sewage Drain Valves    | 28. Storage Compartment        |
| 19. Refrigerator Access     | 24. City Water Connection  | 29. Hood                       |
| 20. Plumbing Vent           | 25. Furnace Intake/Exhaust |                                |

# SECTION 1

## SAFETY PRECAUTIONS

Read and understand all instructions and precautions in this manual before operating your new motor home. The symbol **WARNING** is used throughout the manual to alert you to precautions that involve your personal safety. Read and follow them carefully. Listed are some safety precautions that must be adhered to. These precautions as well as others that involve damage to equipment are also listed in the appropriate areas in this manual.

### General Warnings

- Only seats equipped with seat belts are to be occupied while the vehicle is in motion.
- Make sure all passengers have seat belts fastened in a low and snug position so the force exerted by the belt in a collision will be spread across the strong hip area.
- Never allow passengers to stand or kneel on seats while the vehicle is in motion.
- Sleeping facilities are not to be utilized while vehicle is in motion.
- Examine the escape window and be familiar with its operation, but do not use except in an emergency.
- The fire extinguisher should be inspected monthly for proper charge and operating condition. This should also be done before beginning a vacation or any extended trip.

### Driving

- Do not attempt to adjust the driver's seat while the vehicle is in motion.
- Do not adjust tilt steering in a moving vehicle.
- Do not operate the cruise control on icy or extremely wet roads, winding roads, in heavy traffic or in any other traffic situation where a constant speed cannot be maintained.
- Use care when accelerating or downshifting on a slippery surface. Abrupt speed changes can cause skidding and loss of control.
- Driving through water deep enough to wet the brakes may affect stopping distance or cause the vehicle to pull to one side. Check brake operation in a safe area to be sure they have not been affected. Never operate any vehicle if a difference in braking efficiency is noticeable.
- Adverse weather conditions and extremes in terrain may affect handling and/or performance of your vehicle. Refer to your chassis manual for related information.

### Fuel & LP Gas

- All pilot lights must be extinguished and appliances turned off while refilling the fuel tank or LP tank.
- Never smoke while refilling vehicle fuel tank or LP gas tank.
- Avoid inhaling exhaust gases produced by burned gasoline, diesel fuel or LP gas in items such as the range, chassis engine, generator engine, refrigerator, furnace and water heater. They contain carbon monoxide, which by itself is an odorless, colorless and poisonous gas.
- Do not bring or store LP gas containers, gasoline or other flammable liquids inside the vehicle because a fire or explosion may result. LP gas containers are equipped with safety valves which relieve excessive pressure by discharging gas to the atmosphere.
- Do not alter the LP gas system at any time or in any way.
- Do not fill LP gas container(s) above 80 percent of capacity. Overfilling the LP gas container can result in uncontrolled gas flow which can cause fire or explosion. A properly filled container will contain approximately 80 percent of its volume as liquid LP gas.
- Never use an open flame to test for LP gas leaks. Replace all protective covers and caps on LP system after filling. Make sure valve is closed and door latched securely.



- Never connect natural gas to the LP gas system.
- When lighting range burners do not turn burner controls to "On" and allow gas to escape before lighting match.
- Portable fuel-burning equipment, including wood and charcoal grills and stoves, shall not be used inside the recreational vehicle. The use of this equipment inside the recreational vehicle may cause fires or asphyxiation.
- LP gas regulators must always be installed with the diaphragm vent facing downward. Regulators that are not in compartments have been equipped with a protective cover. Make sure that the regulator vent faces downward and that the cover is kept in place to minimize vent blockage which could result in excessive gas pressure causing fire or explosion.

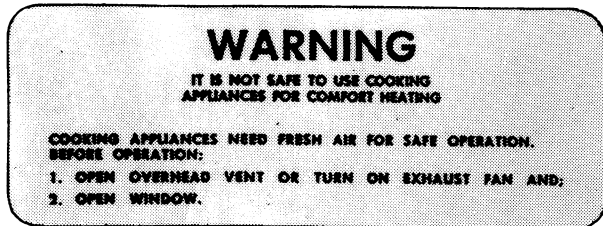

- The above warning label has been located in the cooking area to remind you to provide an adequate supply of fresh air for combustion. Unlike homes, the oxygen supply is limited due to the size of a recreational vehicle. Proper ventilation when using cooking appliances will avoid dangers of asphyxiation. It is especially important that cooking appliances not be used for comfort heating as the danger of asphyxiation is greater when the appliance is used for long periods of time.
- The following label has been placed in the vehicle near the range area:

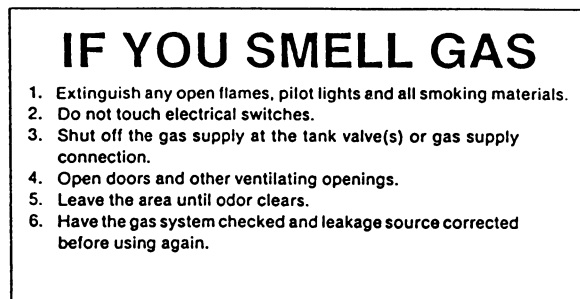

## LP GAS LEAKS

The following label has been placed in the vehicle near the range area. If you smell gas within the vehicle, quickly and carefully perform the procedures listed.

### LP Leak Gauge

Your coach is equipped with a pressure-drop indicator gauge (manometer) to test for LP gas line leaks. This gauge is located in the refrigerator access compartment on the exterior of the coach and is easily accessible when required. A leak test should be performed before using the LP system in the following situations:

- after storage periods.
- each time after opening the main supply valve.
- after each LP tank fill.
- daily during periods of extended use.

Read the following operating instructions and additional information in your Owner Operation Manual before conducting the LP gas leak test.

### IMPORTANT

This device does not prevent leaks. It detects and indicates leakage only while operated and observed.

If the gauge indicates a leak, recheck to be sure all appliance gas valves have been shut off.

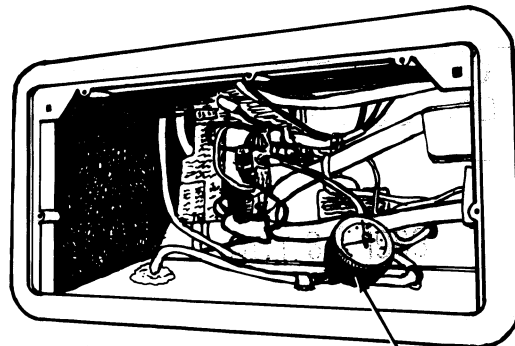

Leak Gauge

(Located in Refrigerator Compartment)

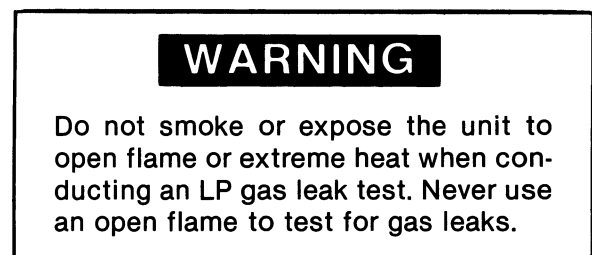

## Instructions:

1. Close LP gas tank or cylinder valve(s).
2. Ventilate vehicle. Open doors and windows.
3. Shut off LP gas appliances, including pilots.
4. Now, slowly open LP gas tank or cylinder valve(s).
5. Observe the pressure reading on the gauge as indicated by the black pointer (A) and match this position with the moveable red pointer (B).

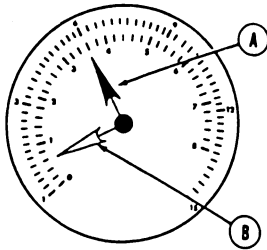

6. Close LP gas tank or cylinder valve(s).
7. With LP gas tank or cylinder valve(s) in a closed position, monitor position of the black pointer for a period of 5 minutes.
  - A. If the black pointer does not move to a lower setting on the gauge, as compared to the red pointer, your system is secure at this time.
  - B. If the black pointer does move to a lower setting on the gauges, as compared to the red pointer, the system has a leak.
8. Conduct a soapy water test at all joints. Tighten if necessary and retest.

## WARNING

Never use an open flame to test for gas leaks.

Check for leaks with the leak gauge each time the gas valve at the tank is opened and each day during periods of prolonged use. When testing for gas line leaks with a soapy water solution, DO NOT use a detergent containing ammonia or chlorine. These substances may generate a chemical reaction causing corrosion to gas lines resulting in dangerous leak conditions.

9. If test still shows a leak, contact your Winnebago/Itasca dealer.

## Electrical

- Careless handling of electrical components can be fatal. Never touch or use electrical components or appliances while feet are bare, while hands are wet, or while standing in water or on wet ground.
- Improper grounding of the vehicle can cause personal injury. Do not plug the utility power cord into an outlet which is not grounded and do not adapt the plug to connect to a receptacle for which it is not designed.
- Do not attach an extension cord to the utility power cord.
- Be sure that all electrical appliances to be used contain 3-prong plugs for proper grounding.
- Avoid overloading electrical circuits. Replace fuses or circuit breakers with those of the same size and amperage rating only. Never use a higher rated fuse or breaker.
- Use caution when handling or working near electrical storage batteries. Always remove jewelry and wear protective clothing and eye covering. Avoid creating sparks.

## Loading

- Store or secure all loose items inside the motor home before traveling.
- Be aware of GVWR, GAWR and individual load limit on each tire or set of duals. (See "Loading the Motor Home" in Section 4.)
- Never load the motor home in excess of the gross vehicle weight rating or the gross axle weight rating for either axle.

## Maintenance

- Do not remove the radiator cap while engine and radiator are still hot. Always check coolant level visually at the see-through coolant reservoir.
- Never get beneath a vehicle that is held up by the jack only.

- Do not mix different construction types of tires on the vehicle such as radial, bias or belted tires, as vehicle handling may be affected. Replace tires with exact size, type and load range.
- Do not attempt to start the vehicle by hot wiring.

## FORMALDEHYDE INFORMATION

### WARNING

Some components in this vehicle contain formaldehyde based adhesives which may release formaldehyde fumes into the air for an unknown period of time until total dissipation occurs. Individuals who are allergic to formaldehyde gas fumes may experience irritation to eyes, ears, nose and throat. Reaction in infants may be more severe. Although long range effects are not well understood, testing to date has not revealed any serious health effects in humans at the level of emission from these products.

## IMPORTANT

To aid in dissipation, ventilate the vehicle by opening all windows and circulating the air with a fan.

## CARBON MONOXIDE WARNING

### WARNING

Avoid inhaling exhaust gases, as they contain carbon monoxide, which is a colorless, odorless and poisonous gas.

If you suspect that exhaust fumes are entering the passenger compartment, have the cause determined and corrected as soon as possible. If you must drive under these conditions, drive only with ALL WINDOWS FULLY OPENED.

The best protection against carbon monoxide entry into the vehicle body is a properly maintained engine exhaust and ventilation system. It is recommended that the exhaust system and body be inspected by a qualified motor home service center.

- Each time the vehicle is raised for an oil change.
- Whenever a change in the sound of the exhaust system is noticed.
- Whenever the exhaust system, underbody or rear of the vehicle is damaged.

To allow proper operation of the vehicle's ventilation system, keep front ventilation inlet grill clear of snow, leaves or other obstructions at all times. **DO NOT OCCUPY A PARKED VEHICLE WITH ENGINE RUNNING FOR AN EXTENDED PERIOD.**

Do not run engine in confined areas, such as a garage, except to move vehicle in or out of area. When vehicle is stopped in an UNCONFINED area with the engine running for any more than a short period, adjust heating or cooling system to force outside air into the vehicle as follows:

1. Set fan to medium or high speed and vent control to "air."
2. On vehicles equipped with air conditioning, set fan to medium or high speed and set control to obtain maximum vent air.

Doors and rear windows should be closed while driving to avoid drawing dangerous exhaust gases into the vehicle.

## EMERGENCY EXITS

### Emergency Exit Window

Your motor home is equipped with an emergency exit window in the rear or the side of the vehicle which functions as an escape exit in an emergency situation. There are two types of emergency exit windows. In one type the glass is installed with a rubber extrusion and is opened by pulling on the red plastic loop located at the bottom of the windows, until the rubber cord is completely removed. This allows the window to be pushed out. In the other type the window is secured by two red safety latches and can be opened by first releasing these two latches and then pushing outward on the lower part of the window. Identify which type of emergency exit

window is in your vehicle. Instructions for removal are also located on a label on the glass for quick reference and for passengers who may not be familiar with the exit. Be sure this label is never removed or destroyed.

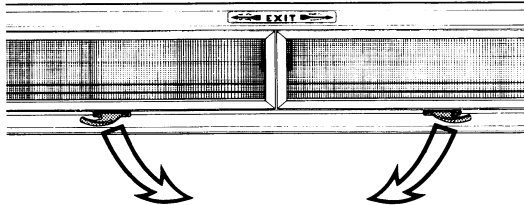

**CAUTION**

Use the window for emergency exit only. Do not test for proper operation.

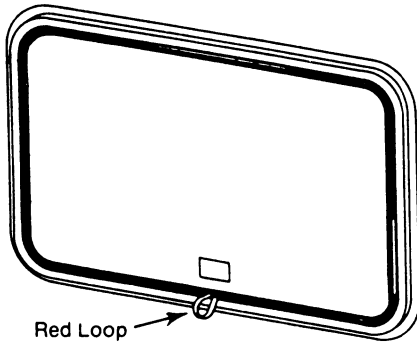

If the cord is released by accident, but the glass remains in place, the cord can be replaced using a blunt instrument, preferably one made of plastic. We suggest you contact your dealer for assistance.

**WARNING**

Use care when exiting emergency window, as broken glass may be present in the exit area.

**Using Slider Windows as Emergency Exits**

Most single and double slider windows along the side of the motor home can also be used as emergency exits, should the need arise. To use

the windows as exits, slide the window open, then strike the screen near one corner to loosen it and push out.

**SAFETY DEVICES**

**FIRE EXTINGUISHER**

A dry chemical fire extinguisher is located near the floor by the side entrance door.

We recommend that you become thoroughly familiar with the operating instructions displayed on the side of the fire extinguisher or in the information supplied in your Motor Home Operations Manual binder.

We also recommend that you inspect the fire extinguisher for proper charge at least once a month in accordance with National Fire Protection Association (NFPA) recommendations as stated on the label.

To test for proper charge, push in on the small, green peg on the side of the fire extinguisher head. If you feel a resistance and the peg immediately pushes back out, the charge is good. If the peg stays in, the charge is insufficient and the fire extinguisher must be replaced.

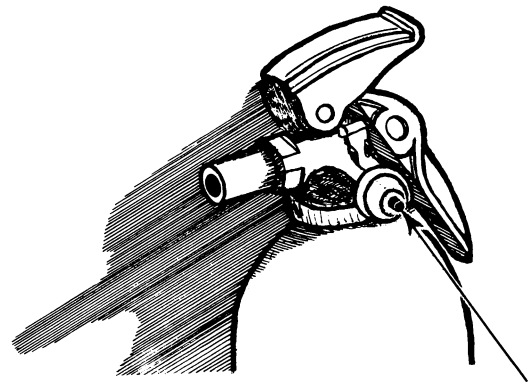

**SMOKE ALARM**

Your motor home is equipped with a smoke alarm located on the ceiling in the galley area. This alarm meets U.L. Standard 217 and NFPA Standard 74 for operation of smoke detection devices.

1. The smoke alarm should be tested for correct operation each time the vehicle is brought out of storage, before each trip and at least once per week during motor home use. To test the electronics, firmly depress the button. To test that smoke reaches the

sensor, blow smoke in a careful, fire-safe manner into your smoke alarm.

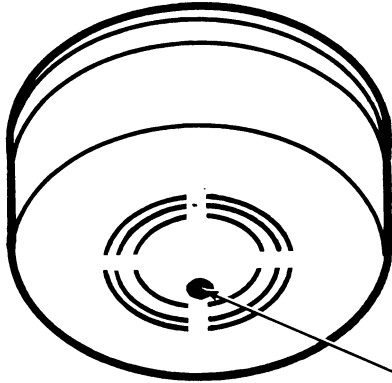

Press  
To  
Test

2. Your smoke alarm will not work without power. Never remove the battery to quiet the alarm. When your smoke alarm “beeps” about once a minute the battery is weak. Immediately install a new battery. Be sure to use only batteries specified in manual or on unit. Test unit after installing a new battery.
3. Clean and vacuum the openings on your smoke alarm once a month.
4. Do not open the smoke alarm or try to repair it. For replacement information see warranty in Owner’s Manual.
5. Smoke alarms have technical limitations and may not respond in all situations. **FIRE PREVENTION** is your best safeguard.

See your motor home Operation Manual binder for further information.

## SECTION 2

# DRIVING YOUR MOTOR HOME

(See also Safety Precautions, Section 1 of this manual.)

### IMPORTANT

This section describes only those instruments and controls which are unique to Winnebago and Itasca motor homes. For complete information regarding all other equipment, controls and instructions, consult the chassis manual or the equipment manufacturer's information provided in your Motor Home Operation Manual. In addition, some items described may be optional or unavailable on your vehicle.

### BEFORE ENTERING YOUR VEHICLE

Before entering your vehicle, there are a few recommended procedures that will aid in your driving safety and equipment.

1. Be sure that the windows, mirrors and light lenses are clean and unobstructed.
2. Make sure all exterior lights operate properly.
3. Check tires for proper cold inflation pressures.
4. Check wheel lug nuts for tightness.
5. Look beneath the vehicle for noticeable fluid leakage.
6. Check fluid levels and fill if necessary. This includes engine oil, transmission fluid, coolant, brake fluid, power steering fluid and windshield washer solvent.

### WARNING

The transmission must be in P (Park) and park brake engaged while performing any checks or adjustments.

The engine should be shut off unless specifically required for a certain procedure.

7. Unhook and store sewer and water supply hoses.
8. Retract step.
9. Be sure that all of your cargo is secured in event of a sudden stop or an accident.

10. Check around your vehicle in all directions to assure that you have proper clearance
11. Lower TV antenna.
12. Disconnect and store shoreline.

### WARNING

Before driving your vehicle, be sure you have read the entire operator's manual and that you understand your vehicle's equipment completely and how to use the equipment safely.

### BEFORE DRIVING YOUR VEHICLE

Before preparing to drive your vehicle, here are a few recommended procedures that will add to your driving safety and enjoyment.

1. Be sure that you adjust the interior and exterior rear view mirrors to your driving preference.
2. Adjust the driver's seat for proper distance from foot pedals and steering wheel to allow for safety and ease in controlling your vehicle.
3. Place front seats in the forward facing position.
4. Be sure to fasten all safety belts to fit you comfortably, but tight enough to obtain the full safety of the belts.
5. Make sure all doors are completely shut and locked. When the doors are locked and shut, there is less chance of the doors flying open in event of an accident. It also prevents unintentional opening of doors and keeps intruders out of your vehicle.
6. Check to see that all gauges are operating properly.
7. Check the fuel level in the vehicle.
8. Be certain that the fire extinguisher is fully charged and secure in its mounting bracket.

## CAUTION

Be sure hood and all compartment doors are latched securely before driving vehicle.

### KEYS

Your motor home is supplied with several sets of keys. In addition to the chassis manufacturer's ignition key, you receive keys for front doors and entrance door, exterior compartment doors and fuel fill.

Each set of keys has an identification number, either on a small metal tag or on a knock-out plug in the key head. Record these numbers and keep them in a safe place. In case keys are lost or stolen, your dealer or a locksmith can provide you with duplicate keys or modify the locks.

### FUEL SELECTION

Refer to your vehicle chassis manual for the manufacturer's recommendations on proper fuel selection.

## WARNING

Modern fuel systems may build up pressure within the tank as the gasoline warms during use or in hot weather.

Under certain conditions, sudden release of this pressure when removing the gasoline cap can spray gasoline from the fuel fill opening, causing a possible hazard.

### GASOLINE FUEL FILL

#### Removing the Fuel Cap

When removing the gasoline cap, slowly rotate it **only far enough to allow pressure to release**. After any "hissing" sounds stop, continue removing the cap.

#### Filling the Tank

**Do not overfill the fuel tank.** Allow gasoline to pump into the tank until the auto-shutoff valve in the fuel pump nozzle stops the flow of fuel, indicating a full tank. This provides a pre-determined

vapor space at the top of the tank to allow for expansion of the gasoline.

## CAUTION

Continuing to fill above this level may cause damage to the fuel/evaporative emissions system.

### Replacement Fuel Caps

To protect gasoline system from excessive pressure or vacuum, or from sudden pressure, replace lost caps with caps of the same design available from your motor home dealer.

### STARTING AND STOPPING ENGINE

Refer to your vehicle chassis manual for the manufacturer's recommendations on starting and stopping the engine.

### PARKING BRAKE (A-Body)

Never drive your vehicle with the parking brake set as this will reduce parking brake effectiveness and cause excessive wear. Your vehicle is equipped with either a pedal or a hand-lever operated parking brake.

#### Instructions for Pedal Operated Parking Brake

The parking brake pedal is located to the left of the foot service brake and to the left of the clutch if equipped.

To set the parking brake, depress the service brake pedal firmly with your right foot while you apply the parking brake with your left foot. The BRAKE warning light will go on as soon as you start to press the parking brake pedal. The brake will not prevent the vehicle from moving unless you push it down firmly and fully. Remove your foot from the service brake pedal and make sure there is no vehicle movement.

To release the parking brake, apply the service brake with your right foot and hold the parking brake pedal down with your left foot while you pull the release lever. The release lever is located above the brake pedal.

#### Instructions for Hand-Lever Operated Parking Brake

The hand-lever is located on the floor on the right side of the driver's seat.

To set the parking brake, hold the brake pedal down and pull the hand-lever up as far as it will go. The BRAKE warning light will go on as soon

as you start to pull the lever. If the parking brake does not hold the vehicle securely, it can be adjusted by turning the knurled adjustment knob at the end of the lever while the parking brake is released. As the effort to set the brake increases, the degree of brake application also increases.

To release the parking brake, hold the brake pedal down while pushing the lever all the way down. Make sure the lever is completely disengaged and the brake warning light is out before driving.

### Parking Brake (C-Body)

Consult your vehicle chassis manual in your Motor Home Operations Manual.

### HAZARD WARNING LIGHTS

See chassis manual or "Instrument Panels" in this section for location of hazard flasher switch. See also Section 3 for further operating information.

### FUEL PUMP SHUT-OFF SWITCH (Oshkosh and Ford Chassis Only)

Vehicles built on Oshkosh and Ford chassis are equipped with an inertial type switch that shuts off the fuel pump in the event of collision. This switch must be manually reset to resume the fuel supply to the engine.

See your vehicle chassis manual for location and reset procedures for this switch.

### IMPORTANT

It is possible to inadvertently trigger this switch by abruptly striking an object such as a curb or parking block. If your vehicle exhibits symptoms of running out of fuel immediately after such an occurrence, the fuel pump shut-off switch may need to be reset.

Consult your vehicle chassis manual for additional information.

### DOOR LOCKS AND HANDLES

#### IMPORTANT

Keys should always be removed when leaving the vehicle. Since doors can be locked without keys, make sure they have been removed from the ignition before locking the driver's compartment.

#### Elandan & Windcruiser

To lock and unlock the entrance and cab doors from the outside of the vehicle, insert the key into the lock and turn.

To open the cab and entrance doors from the inside of the vehicle, pull the latch lever outward. The doors are locked from the inside of the vehicle using the lock rocker switch. Deadbolts are also provided for extra security.

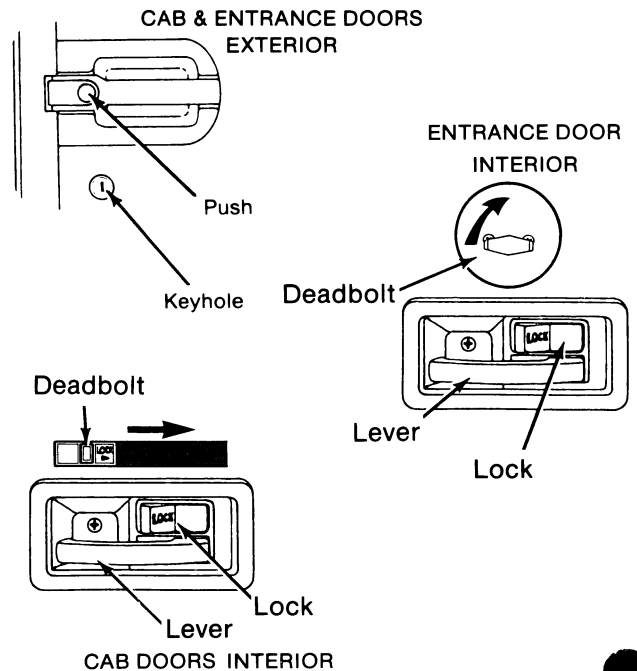

#### All Models except Elandan & Windcruiser

To lock and unlock the cab doors from the outside of the vehicle, insert the key into the lock and turn.

To open the cab doors from the inside of the vehicle, pull the latch lever outward. The doors are locked from the inside of the vehicle using the lock rocker switch. Deadbolts are also provided for extra security.

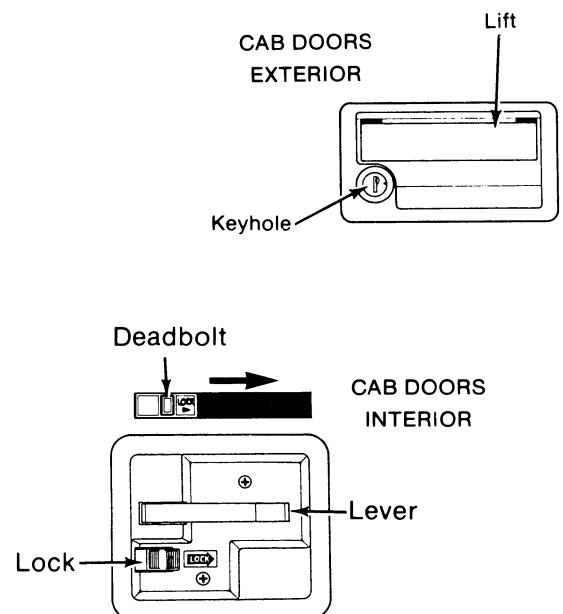



The entrance door may be opened from outside the vehicle by pulling the door handle outward. To open the door from inside, pull upward on the door handle. When the door is locked, neither the inside nor the outside door handle can be operated.

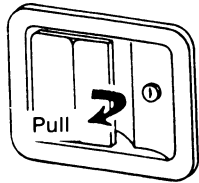

The entrance door can be locked or unlocked from the outside of the vehicle by inserting the key into the lock and turning. To lock the door from inside, slide the lock button to the right. The deadbolt locks are for added security and should be used as security night locks. Lubricate the locks periodically with graphite to maintain good working condition.

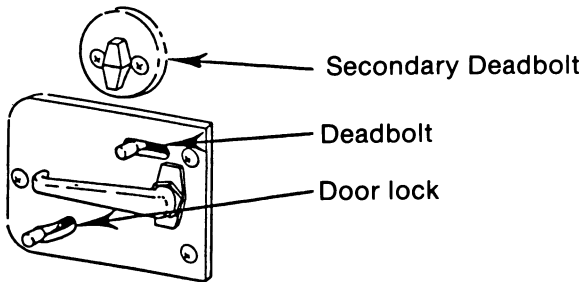

**CAUTION**

When releasing security night lock, be sure to retract bolt before opening door latch to prevent drag on bolt pin. Instruct all passengers in operation of this door catch system as well as emergency exit window.

Never force the inside door handle downward, as damage could occur.

**DRIVER COMPARTMENT DOOR LOCK (C-Body Only)**

Consult your vehicle chassis manual.

**POWER DOOR LOCKS—Optional**

Cab and entrance doors may be locked or unlocked using the switches located on the inside door panels.

Doors may also be locked or unlocked from outside the vehicle using the door key in the usual manner.

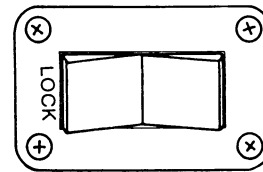

**POWER WINDOWS—Optional**

The driver's door window may be raised up or down using the switch located on the top edge of the driver door.

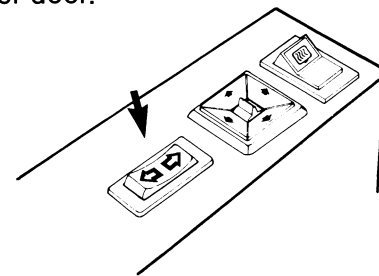

**ENTRANCE STEP—Manual**

To extend the entrance step, lift up on the front of the step and pull out until it drops into position. To retract, lift up on front of step and push back until step locks into travel position.

**ENTRANCE STEP—Powered**

The step power switch is located to the right of the door as you exit. See the power step owner's manual in your Motor Home Operations Manual for operating instructions and additional information.

**CAUTION**

The steps will remain extended, and can be damaged, if the auxiliary battery disconnect switch is not connected before leaving a site after the steps have been locked in the extended position. The Auxiliary Battery Disconnect Switch should only be turned off (disconnected) when storing your vehicle.

**WARNING**

Do not use steps unless they are fully extended.

## CAUTION

Always remember to retract the entrance step before traveling or moving the vehicle.

### SEATS—Standard (Except Elandan & Windcruiser)

The driver and co-pilot seats may be independently adjusted to suit individual preference. To move the seat forward or backward, move the slide release lever, located under the front of the seat, to the left and exert slight body pressure in the direction desired.

The seats may be swiveled to provide easy entrance and exit. The swivel feature also allows the seats on some models to be turned toward the living area for additional seating while the unit is parked. To swivel the seats, press the release lever, located on the right side of the seat, to the rear and rotate seat. The seats are designed to lock only when returned to the forward facing position.

To recline the seats, depress reclining lever, lean back to desired incline and release the lever. To return to the upright position, depress the lever and lean body forward. Allow the seat to return to the desired position and release the lever.

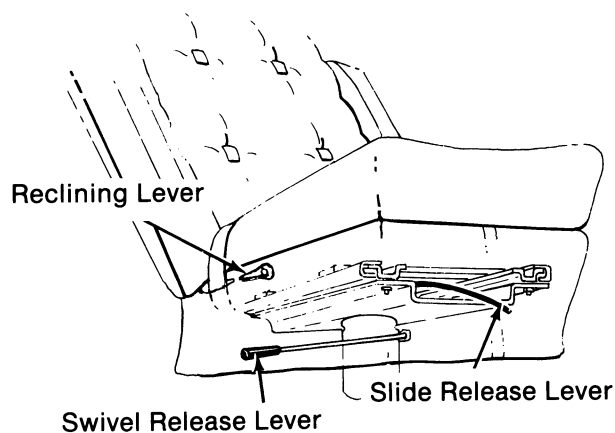

## WARNING

Do not adjust drivers seat while vehicle is in motion.

After adjusting seat, always use body pressure to make sure slide and swivel locking mechanisms have engaged.

### Arm Rest Adjustment

The seat assembly arm rest may be adjusted to alter the angle at which the arm rest will remain when placed in the lowered position. To reposition the arm rest angle, proceed as follows:

Position 1—Raise armrest, push in toward seat body and lower into position.

Position 2—Raise armrest, pull outward from seat body and lower into position.

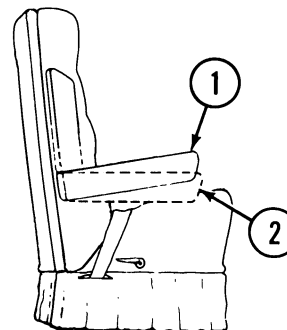

### SEATS—Elandan and Windcruiser

The recliner and slider controls are located at the front of the armrests.

**To Recline:** The control lever is located at the front of the right armrest.

1. Lean body forward slightly to reduce pressure on seat back.
2. Pull upward on control lever.
3. Lean body and seat back to desired angle of recline.
4. Release lever.

Return the seat back to an upright position by pulling the control lever upward and leaning your body forward at the same time.

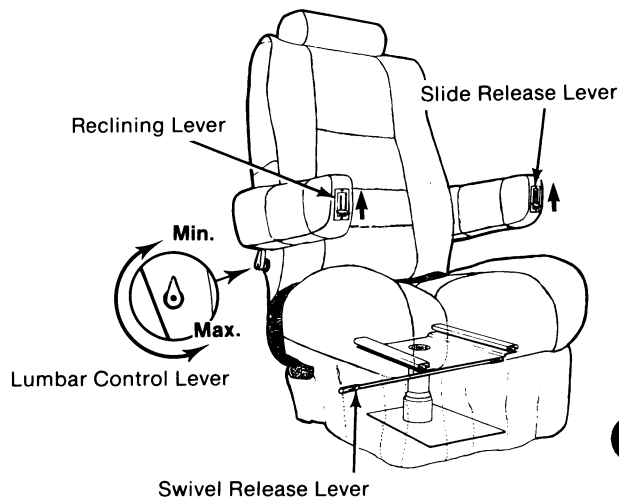

**To Move the Seat Forward or Backward:** The control lever is located at the front of the left armrest.

1. Pull upward on control lever.
2. Use body motion to move seat forward/backward as desired.
3. Release lever.

**Armrest Adjustment:** See “Seats—Standard.”

### SEATS—Optional 6-Way Powered

The driver seat is adjusted using the switch panel shown, located on the left-hand side of the seat. Switch 1 controls seat front elevation and switch 3 controls the seat rear elevation. The fore-aft positioning of the seat is controlled by switch 2.

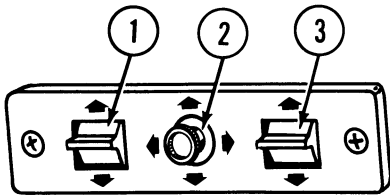

Power Seat Control

Refer to “Seats—Elandan and Windcruiser” for armrest positions and seat reclining instructions.

### POWER CO-PILOT SEAT (Chieftain/Sunflyer 27RT & 31RQ Only)

On these models, the co-pilot front seat doubles as the front lounge chair while parked. To use, swivel the seat to face rearward and press the switch on the wall to raise or lower. Always return the seat to the front facing travel position before the vehicle is in motion for proper use of seat belts.

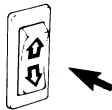

### SWIVEL/RECLINER LOUNGE CHAIRS

Some vehicles are equipped with lounge chairs which swivel and recline. They may also be moved fore and aft on a slider mechanism. Refer to “Seats—Elandan and Windcruiser” for reclining and slider adjustment instructions.

These chairs feature a slide-facing swivel lock for your safety while the vehicle is moving.

**To Lock:** The lock handle is located below the right side of the seat, behind the skirt.

1. Turn handle so that it points either upward or downward.
2. Swivel chair to aisle-facing position.
3. When you hear a “click,” seat is locked into position.

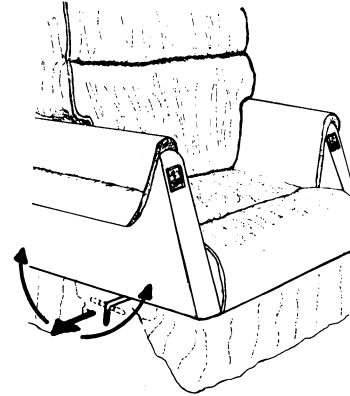

**To Unlock:** Pull the handle outward (away from the seat base) and turn it to a horizontal position. The seat can now swivel freely.

### SEAT BELTS

Seats intended for occupancy while the vehicle is in motion are equipped with seat belts for the protection of the driver and passengers. The lap belts must be worn as low as possible and fit snugly across the hip area. Always sit erect and well back into the seat. To implement full protection of the safety belt, never allow more than one occupant to use the same safety belt at any one time, and do not let the safety belts become damaged by pinching them in the doors or in the seat mechanism. After any serious accident, any safety belts which were in use at the time should be replaced.

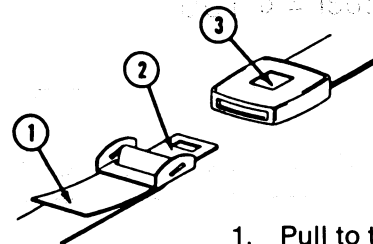

1. Pull to tighten.
2. Tongue.
3. Push to release.

**Adjustment:** To lengthen belt, turn tongue at a right angle to belt and pull to desired length. To shorten, pull loose end of belt.

**To Fasten:** Be sure belt is not twisted. Grasp each part of the belt assembly and push tongue into buckle. Adjust to a snug fit by pulling the loose end away from the tongue.

**To Release:** Depress button in center of buckle and slide tongue out of buckle.

## WARNING

Snug and low belt positions are essential. This will ensure that the force exerted by the lap belt in a collision is spread over the strong hip area and not across the abdomen, which could result in serious injury.

Only seats equipped with seat belts are to be occupied while vehicle is in motion.

### Lap-Shoulder Belt

**Fastening:** Hold the belt just behind the tongue using the hand nearest to the door. Next, bring the belt across your body and slide the tongue into the buckle until the latch engages.

**Unfastening:** Press the release button in the buckle. Hold onto the tongue when you release it from the buckle to keep it from retracting too rapidly.

When the lap-shoulder belt is in use, the lap portion must ride across the strong hip area and the shoulder portion must ride diagonally over the shoulder blade toward the buckle.

The shoulder belt is designed to lock only during a sudden stop, sudden body movement or a collision. At all other times it will move freely with the occupant.

## WARNING

Never wear the shoulder belt in any position other than as stated above. Failure to do so could increase the chance or extent of injury in a collision.

### CHILD RESTRAINTS

All 50 of the United States and the District of Columbia now require the use of child/infant restraint systems for children in vehicles.

A properly installed and secured child restraint system can help reduce the chance of severity of personal injury to a child in an accident or during a sudden maneuver. Children may be injured in an accident if they are not seated in a child restraint system or if seated in a child restraint system which is not properly secured.

A child restraint system is designed to be secured in a vehicle seat by a lap belt or the lap belt portion of a lap-shoulder belt. According to accident statistics, children are also safer when properly restrained in rear seating positions than in front seating positions.

When purchasing a child restraint system:

1. Look for the label certifying that it meets all applicable U.S. Federal Motor Vehicle Safety Standards (FMVSS) or, in Canada, requirements of the Children's Car Seats and Harnesses Regulations (CCSHR).
2. Make sure that it will attach to your vehicle and restrain your child securely and conveniently so that you are able to install it correctly each time it is used.
3. Be certain that it is appropriate for the child's height, weight and development. The instructions and/or the regulation label attached to the restraint typically provides this information.
4. Review the instructions for installation and use of the restraint. Be sure that you understand them fully and can install the restraint properly and safely in your vehicle.

### OUTSIDE MIRRORS

Always adjust mirrors for maximum rear visibility before driving off. Make sure the seat is adjusted for proper vehicle control and that you are sitting back squarely into the seat.

#### Standard Mirrors

Tilt the surface of the mirror gently up or down, left or right, to obtain the best rear view.

#### POWER ELECTRIC MIRRORS—Optional

The electric mirrors are adjusted using a multi-directional switch located on the driver's door or the driver's side panel.

Select the mirror to be adjusted by pushing the switch in the middle of the control to the right or

left. Then press the arrow buttons as necessary to obtain the best view.

When mirrors are adjusted to preference, place the selector switch back in the middle position to cancel power to the buttons. This prevents accidental misadjustment of mirror settings.

The mirrors also contain heating elements to defog or de-ice the mirror glass during cold weather operation. An ON-OFF switch for the mirror heaters is located near the remote mirror controls.

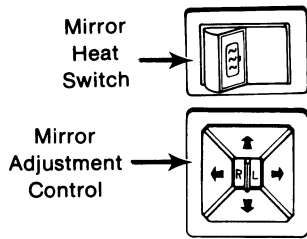

### REAR VISION CAMERA/MONITOR SYSTEM—Optional

If your motor home is equipped with this optional system, refer to the Motor Home Operation Manual for specific instructions.

The following illustrations show all available features.  
Your motor home may not be equipped with every option.

### INSTRUMENT PANEL - Warrior/Spirit (Toyota Chassis)

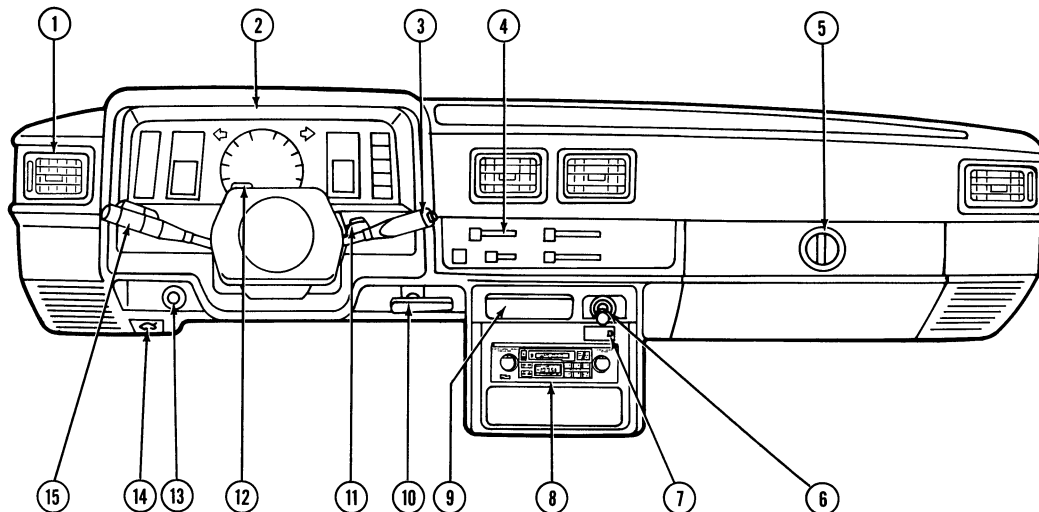

- |                                    |                               |                              |
|------------------------------------|-------------------------------|------------------------------|
| 1. Vent Register                   | 6. Cigarette Lighter          | 11. Ignition Switch          |
| 2. Instrument Cluster              | 7. Overdrive Indicator Light  | 12. Emergency Flasher Switch |
| 3. Windshield Wiper/Washer Switch  | 8. Audio Entertainment System | 13. Instrument Panel Dimmer  |
| 4. Heater/Air Conditioner Controls | 9. Ashtray                    | 14. Hood Release             |
| 5. Glove Compartment               | 10. Park Brake Lever          | 15. Headlight/Dimmer/Signal  |

### INSTRUMENT PANEL - Minnie Winnie/Sundancer/Warrior/Spirit (Ford Chassis)

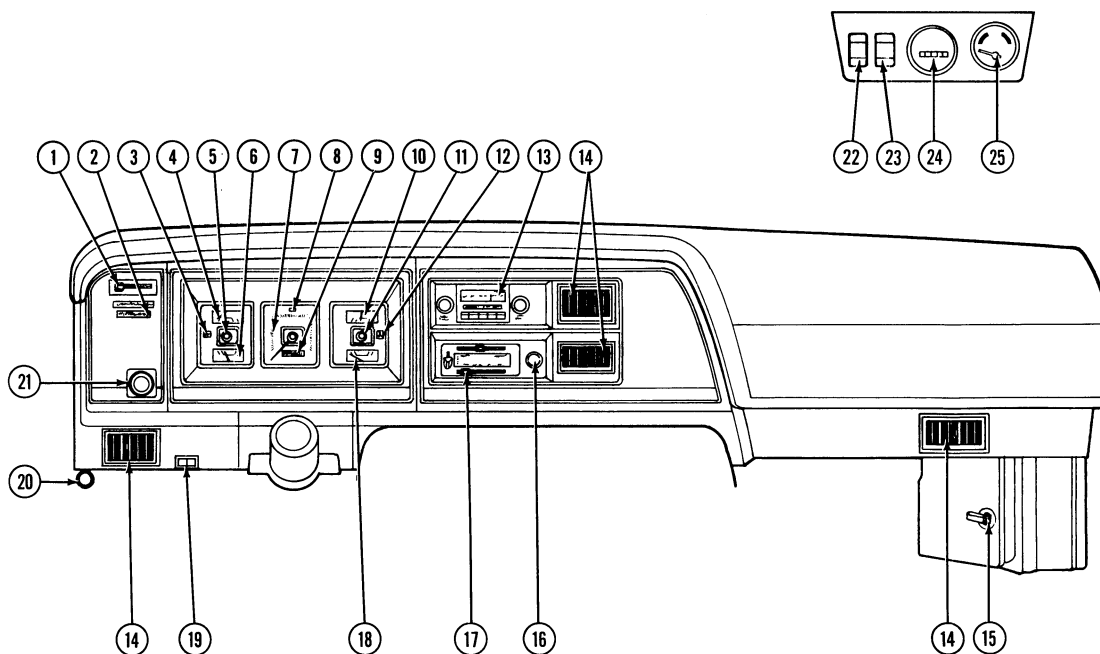

- |  |                                     |  |
|--|-------------------------------------|--|
| 1. Windshield Wiper/Washer Switch      | 9. Odometer                         | 19. Battery Mode Switch                            |
| 2. Rear Windshield/Wiper/Washer Switch | 10. Alternator Indicator            | 20. Left Fresh Air Vent Knob                       |
| 3. Seat Belt Reminder Light            | 11. Right Turn Indicator            | 21. Headlight Switch                               |
| 4. Oil Pressure Indicator              | 12. Brake Warning Light             | 22. Battery Condition Switch                       |
| 5. Left Turn Indicator                 | 13. Radio                           | 23. Auxiliary Electric Generator Start/Stop Switch |
| 6. Fuel Gauge                          | 14. Vent/Air Conditioner Controls   | 24. Auxiliary Electric Generator Hourmeter         |
| 7. Speedometer                         | 15. Right Fresh Air Vent Knob       | 25. Battery Condition Meter                        |
| 8. High Beam Indicator                 | 16. Cigarette Lighter               |  |
|  | 17. Heater/Air Conditioner Controls |  |
|  | 18. Engine Temperature Gauge        |  |

**INSTRUMENT PANEL - Warrior/Spirit  
(Chevrolet Chassis)**

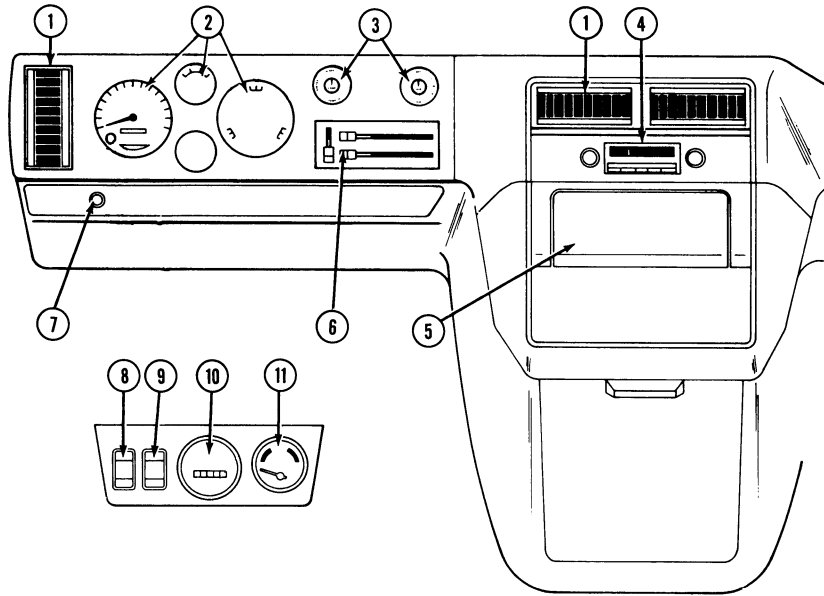

- |                                    |   |
|------------------------------------|---|
| 1. Vent/Air Conditioner Register   | 7. Headlight Switch                               |
| 2. Instrument Cluster              | 8. Battery Condition Switch                       |
| 3. Air Conditioner Controls        | 9. Auxiliary Electric Generator Start/Stop Switch |
| 4. Audio Entertainment System      | 10. Auxiliary Electric Generator Hourmeter        |
| 5. Ashtray/Cigarette Lighter       | 11. Battery Condition Meter                       |
| 6. Heater/Air Conditioner Controls |   |

**INSTRUMENT PANEL - Minnie Winnie/Sundancer/Warrior/Spirit  
(Chevrolet Chassis)**

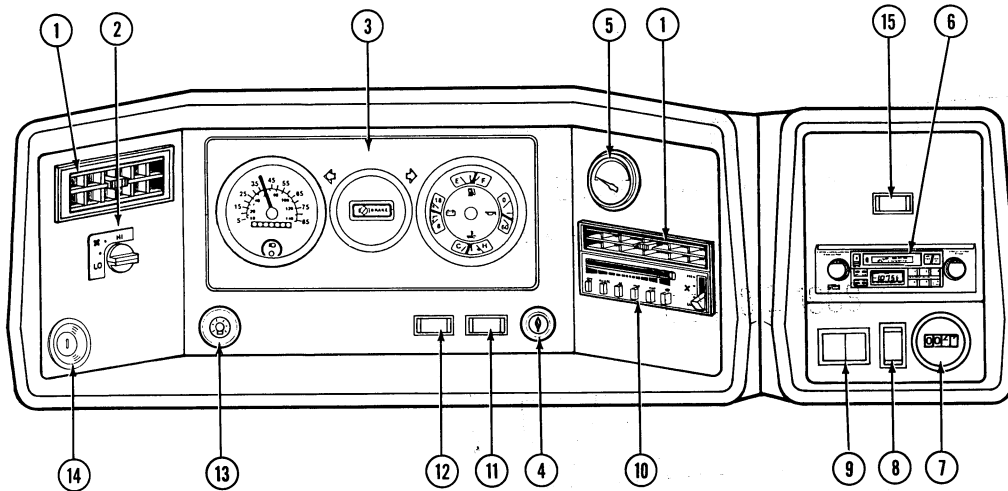

- |                                |   |                              |
|--------------------------------|---|------------------------------|
| 1. Vent/Air Condition Register | 6. Audio Entertainment System                     | 11. Battery Mode Switch      |
| 2. Rear Auto Heater Switch     | 7. Auxiliary Electric Generator Hourmeter         | 12. Battery Condition Switch |
| 3. Instrument Cluster          | 8. Auxiliary Electric Generator Start/Stop Switch | 13. Headlight Switch         |
| 4. Cigarette Lighter           | 9. Choke/Check Engine Indicator                   | 14. Ignition Switch          |
| 5. Battery Condition Meter     | 10. Heater/Air Conditioner Controls               | 15. Radio Power Switch       |

**INSTRUMENT PANEL - Superchief/Suncruiser  
(Chevrolet Chassis)**

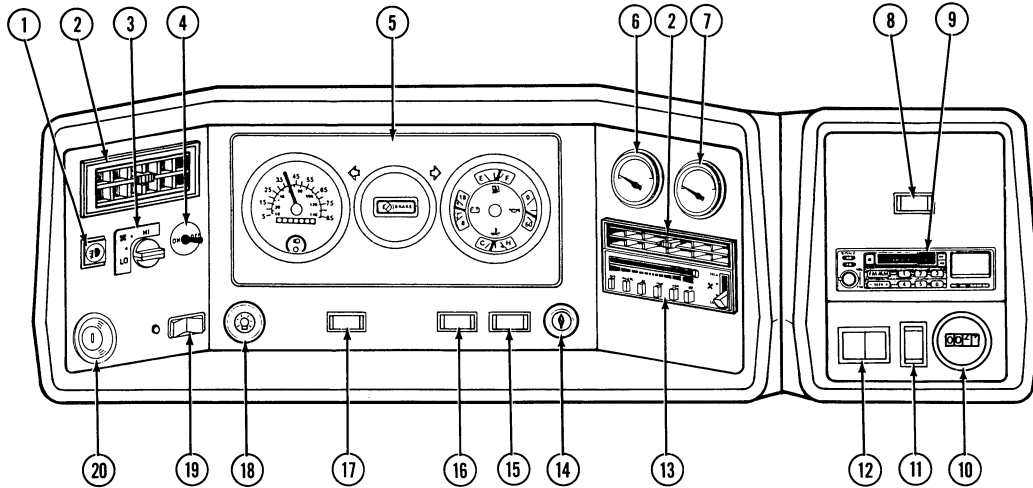

- |   |   |
|---|---|
| 1. Fog Light Switch                           | 11. Auxiliary Electric Generator<br>Start/Stop Switch |
| 2. Vent/Air Conditioner Register              | 12. Choke/Check Engine Indicator                      |
| 3. Rear Auto Heater Switch                    | 13. Heater/Air Conditioner Controls                   |
| 4. Air Horn Switch                            | 14. Cigarette Lighter                                 |
| 5. Instrument Cluster                         | 15. Battery Mode Switch                               |
| 6. Battery Condition Meter                    | 16. Battery Condition Switch                          |
| 7. Vacuum/Fuel Economy Gauge                  | 17. Rear Wiper Switch                                 |
| 8. Radio Power Switch                         | 18. Headlight Switch                                  |
| 9. Audio Entertainment System                 | 19. Auxiliary Battery Switch                          |
| 10. Auxiliary Electric Generator<br>Hourmeter | 20. Ignition Switch                                   |

**INSTRUMENT PANEL - Superchief/Suncruiser  
(Chevrolet Chassis - Electronic Instrumentation)**

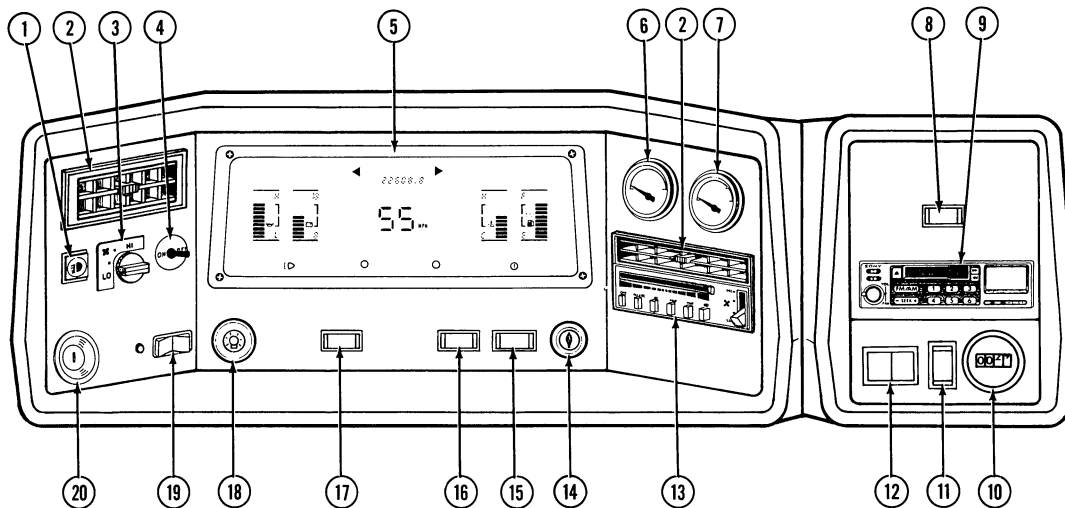

- |   |   |
|---|---|
| 1. Fog Light Switch                           | 11. Auxiliary Electric Generator<br>Start/Stop Switch |
| 2. Vent/Air Condition Register                | 12. Choke/Check Engine Indicator                      |
| 3. Rear Auto Heater Switch                    | 13. Heater/Air Conditioner Controls                   |
| 4. Air Horn Switch                            | 14. Cigarette Lighter                                 |
| 5. Instrument Cluster                         | 15. Battery Mode Switch                               |
| 6. Battery Condition Meter                    | 16. Battery Condition Switch                          |
| 7. Vacuum/Fuel Economy Gauge                  | 17. Rear Wiper Switch                                 |
| 8. Radio Power Switch                         | 18. Headlight Switch                                  |
| 9. Audio Entertainment System                 | 19. Auxiliary Battery Switch                          |
| 10. Auxiliary Electric Generator<br>Hourmeter | 20. Ignition Switch                                   |



**INSTRUMENT PANEL - Superchief/Suncruiser  
(Ford Chassis)**

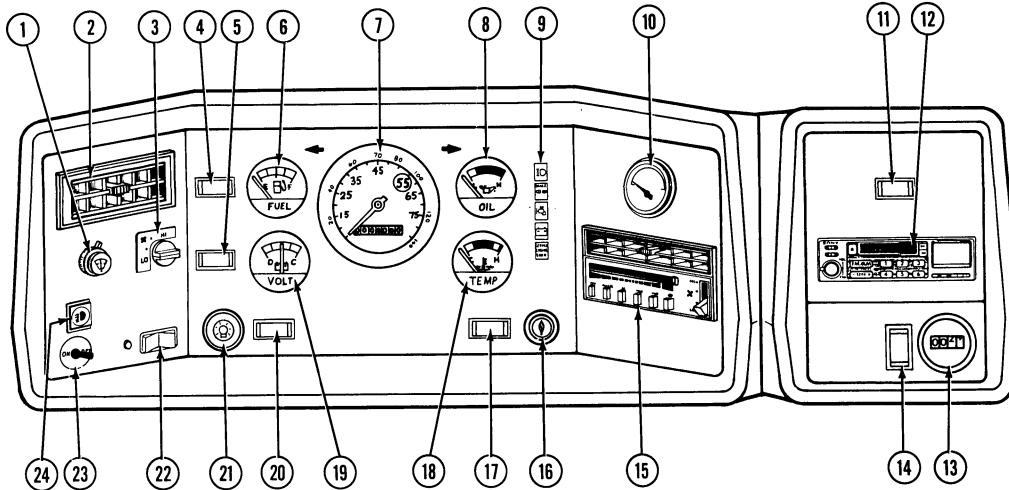

- |   |  |
|---|--|
| 1. Windshield Wiper/Washer/Delay Switch   | 12. Audio Entertainment Center                     |
| 2. Vent/Air Conditioner Register  | 13. Auxiliary Electric Generator Hourmeter         |
| 3. Rear Auto Heater Switch  | 14. Auxiliary Electric Generator Start/Stop Switch |
| 4. Battery Condition Switch   | 15. Heater/Air Conditioner Control                 |
| 5. Battery Mode Switch  | 16. Cigarette Lighter                              |
| 6. Fuel Gauge   | 17. Rear Wiper Switch                              |
| 7. Speedometer  | 18. Coolant Temperature Gauge                      |
| 8. Oil Pressure Gauge   | 19. Battery Condition Meter                        |
| 9. High Beam/Brake System - Park Brake/Check Engine/Alternator/Service Engine Soon Indicators | 20. Rear Fan Switch                                |
| 10. Vacuum/Fuel Economy Gauge   | 21. Headlight Switch                               |
| 11. Radio Power Switch  | 22. Auxiliary Battery Switch                       |
|   | 23. Air Horn Switch                                |
|   | 24. Fog Light Switch                               |

**INSTRUMENT PANEL - Superchief DX/L/Suncruiser DX/L**

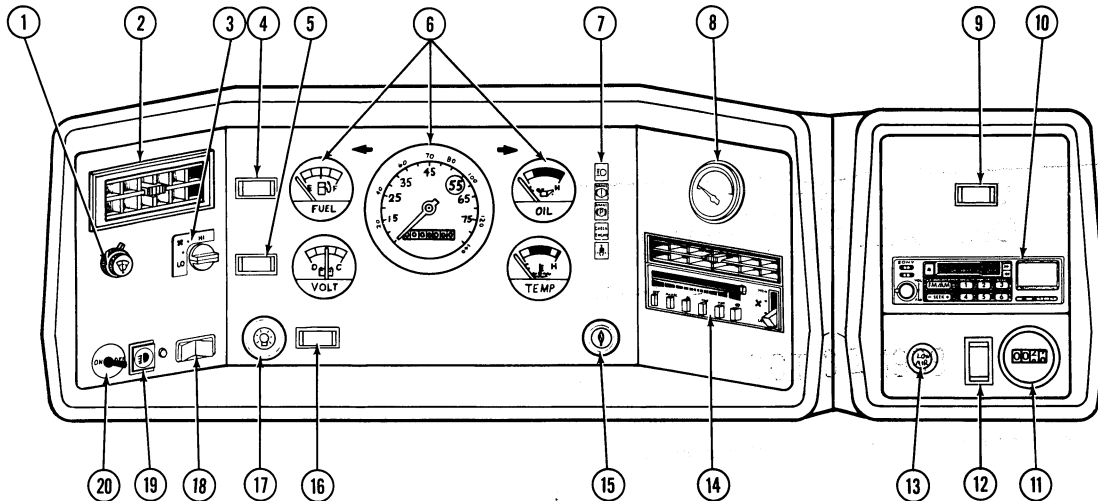

- |   |  |
|---|--|
| 1. Windshield Wiper/Washer/Delay Switch                   | 11. Auxiliary Electric Generator Hourmeter         |
| 2. Vent/Air Conditioner Register                          | 12. Auxiliary Electric Generator Start/Stop Switch |
| 3. Rear Auto Heater Switch                                | 13. Low Air Indicator                              |
| 4. Battery Mode Switch                                    | 14. Heater/Air Conditioner Control                 |
| 5. Battery Condition Switch                               | 15. Cigarette Lighter                              |
| 6. Instrument Cluster                                     | 16. Rear Fan Switch                                |
| 7. High Beam/Brake System/Park Brake/Seat Belt Indicators | 17. Headlight Switch                               |
| 8. Vacuum/Fuel Economy Gauge                              | 18. Auxiliary Battery Switch                       |
| 9. Radio Power Switch                                     | 19. Fog Light Switch                               |
| 10. Audio Entertainment Center                            | 20. Air Horn Switch                                |

**INSTRUMENT PANEL - Chieftain/Sunflyer  
(Chevrolet Chassis)**

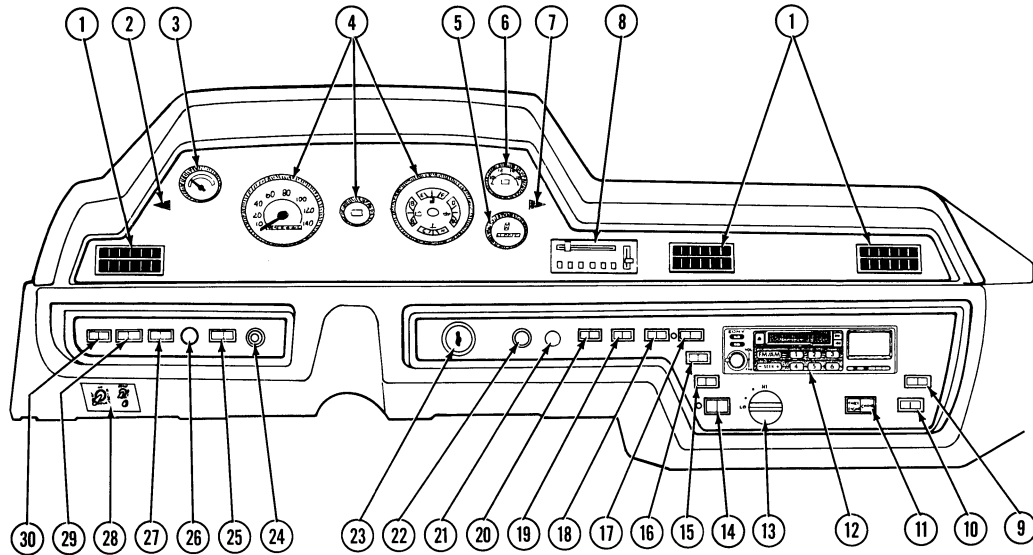

- |                                  |                                     |   |
|----------------------------------|-------------------------------------|---|
| 1. Vent/Air Conditioner Register | 11. Check Engine/Choke Indicator    | 21. Low Air Warning Light (Tag Axle Only) |
| 2. Left Turn Indicator           | 12. Audio Entertainment System      | 22. Cigarette Lighter                     |
| 3. Vacuum/Fuel Economy Gauge     | 13. Rear Auto Heater Switch         | 23. Ignition Switch                       |
| 4. Instrument Cluster            | 14. Auxiliary Battery Switch        | 24. Headlight Switch                      |
| 5. Auxiliary Generator Hourmeter | 15. Radio Power Switch              | 25. ICC Courtesy Blink Switch             |
| 6. Battery Condition Meter       | 16. Auxiliary Windshield Fan Switch | 26. Leveling Jacks Down Indicator         |
| 7. Right Turn Indicator          | 17. Auxiliary Generator Switch      | 27. Battery Mode Switch                   |
| 8. Heater A/C Controls           | 18. Fog Light Switch                | 28. Rear Washer Switch                    |
| 9. Map Light Switch              | 19. Battery Condition Switch        | 29. Remote Flood/Spotlight Control        |
| 10. Beverage Light Switch        | 20. Air Horn Compressor Switch      | 30. Rear Wiper Switch                     |

**INSTRUMENT PANEL - Chieftain/Sunflyer  
(Chevrolet Chassis - Electronic Instrumentation)**

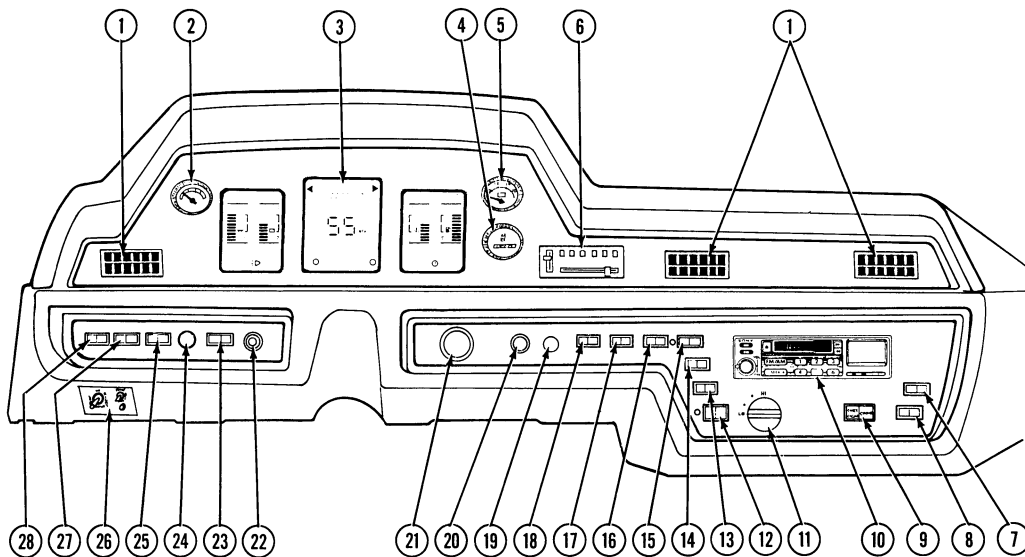

- |                                  |   |                                    |
|----------------------------------|---|------------------------------------|
| 1. Vent/Air Conditioner Register | 11. Rear Auto Heater Switch               | 20. Cigarette Lighter              |
| 2. Vacuum/Fuel Economy Gauge     | 12. Auxiliary Battery Switch              | 21. Ignition Switch                |
| 3. Instrument Panel              | 13. Radio Power Switch                    | 22. Headlight Switch               |
| 4. Auxiliary Generator Hourmeter | 14. Auxiliary Windshield Fan Switch       | 23. ICC Courtesy Blink Switch      |
| 5. Battery Condition Meter       | 15. Auxiliary Generator Switch            | 24. Leveling Jacks Down Indicator  |
| 6. Heater A/C Controls           | 16. Fog Light Switch                      | 25. Battery Mode Switch            |
| 7. Map Light Switch              | 17. Battery Condition Switch              | 26. Remote Flood/Spotlight Control |
| 8. Beverage Tray Light Switch    | 18. Air Horn Compressor Switch            | 27. Rear Washer Switch             |
| 9. Check Engine/Choke Indicator  | 19. Low Air Warning Light (Tag Axle Only) | 28. Rear Wiper Switch              |
| 10. Audio Entertainment System   |   |                                    |

**INSTRUMENT PANEL - Chieftain/Sunflyer  
(Ford Chassis)**

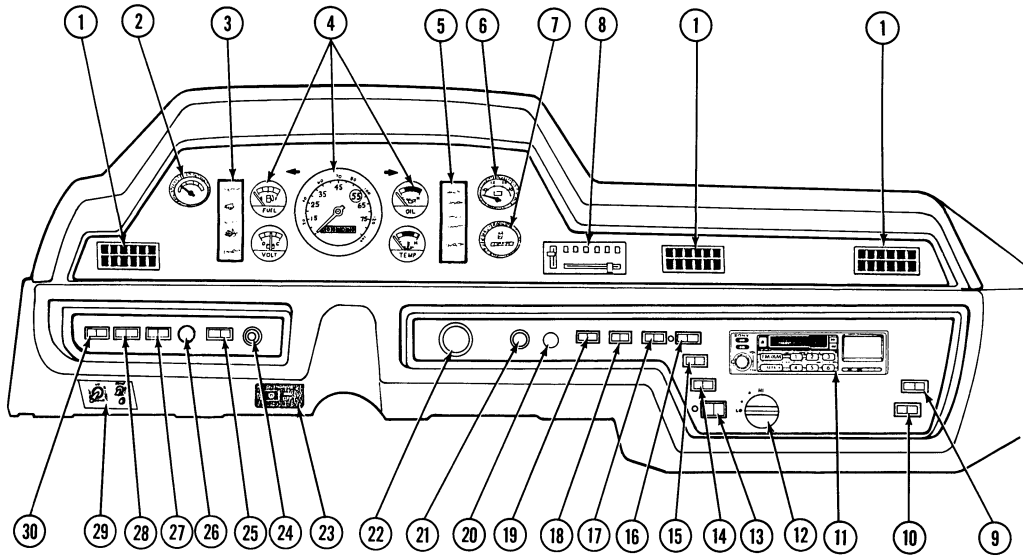

- |   |  |                                    |
|---|--|------------------------------------|
| 1. Vent/Air Conditioner Register                              | 11. Audio Entertainment System               | 21. Cigarette Lighter              |
| 2. Vacuum/Fuel Economy Gauge                                  | 12. Rear Auto Heater Switch                  | 22. Windshield Wiper/Washer Switch |
| 3. Service Engine Soon/Alternator/<br>Check Engine Indicators | 13. Auxiliary Battery Switch                 | 23. Overdrive Cancel Switch        |
| 4. Instrument Cluster   | 14. Radio Power Switch                       | 24. Headlight Switch               |
| 5. Highbeam/Brake System - Park<br>Brake Indicators           | 15. Auxiliary Windshield Fan Switch          | 25. ICC Courtesy Blink Switch      |
| 6. Battery Condition Meter                                    | 16. Auxiliary Generator Switch               | 26. Leveling Jacks Down Indicator  |
| 7. Auxiliary Generator Hourmeter                              | 17. Fog Light Switch                         | 27. Battery Mode Switch            |
| 8. Heater A/C Controls  | 18. Battery Condition Switch                 | 28. Rear Washer Switch             |
| 9. Map Light Switch   | 19. Air Horn Compressor Switch               | 29. Remote Flood/Spotlight Control |
| 10. Beverage Tray Light Switch                                | 20. Low Air Warning Light (Tag Axle<br>Only) | 30. Rear Wiper Switch              |

**INSTRUMENT PANEL - Elandan/Windruiser  
(Ford Chassis)**

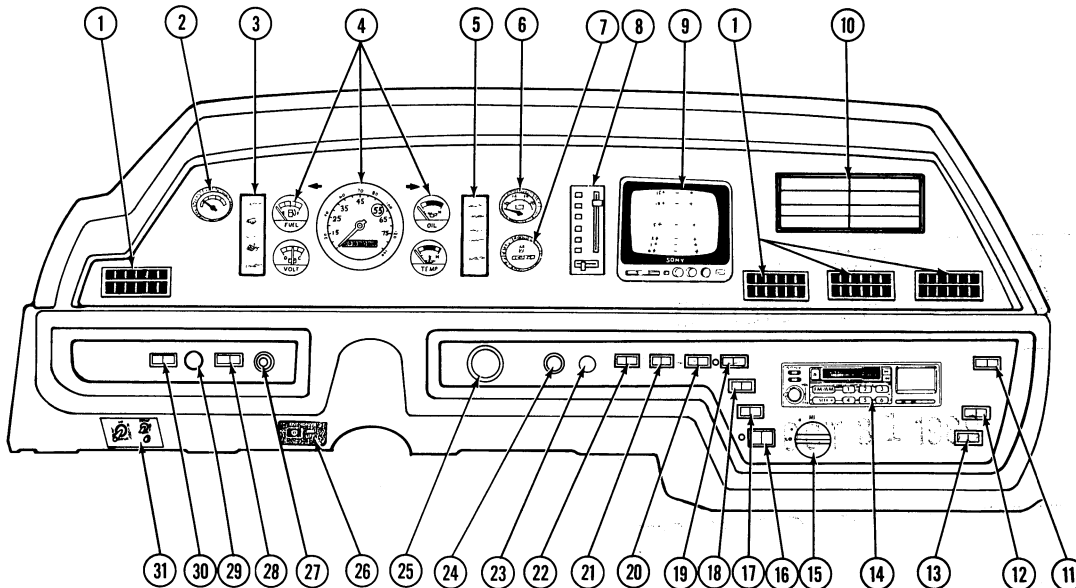

- |   |                                     |  |
|---|-------------------------------------|--|
| 1. Vent/Air Conditioner Register                              | 11. Courtesy Lights Switch          | 21. Battery Condition Switch                 |
| 2. Vacuum/Fuel Economy Gauge                                  | 12. Map Light Switch                | 22. Air Horn Compressor Switch               |
| 3. Service Engine Soon/Alternator/<br>Check Engine Indicators | 13. Beverage Tray Light Switch      | 23. Low Air Warning Light (Tag Axle<br>Only) |
| 4. Instrument Panel   | 14. Audio Entertainment System      | 24. Cigarette Lighter                        |
| 5. High Beam/Brake System - Park<br>Brake Indicators          | 15. Rear Auto Heater Switch         | 25. Wiper/Washer Control                     |
| 6. Battery Condition Meter                                    | 16. Auxiliary Battery Switch        | 26. Overdrive Cancel Switch                  |
| 7. Auxiliary Generator Hourmeter                              | 17. Radio Power Switch              | 27. Headlight Switch                         |
| 8. Heater A/C Controls  | 18. Auxiliary Windshield Fan Switch | 28. ICC Courtesy Blink Switch                |
| 9. Rearview Monitor   | 19. Auxiliary Generator Switch      | 29. Leveling Jacks Down Indicator            |
| 10. Cassette Tape Holder                                      | 20. Fog Light Switch                | 30. Battery Mode Switch                      |
|   |                                     | 31. Remote Flood/Spotlight Control           |

**INSTRUMENT PANEL - Elandan/Windcruiser  
(Chevrolet Chassis)**

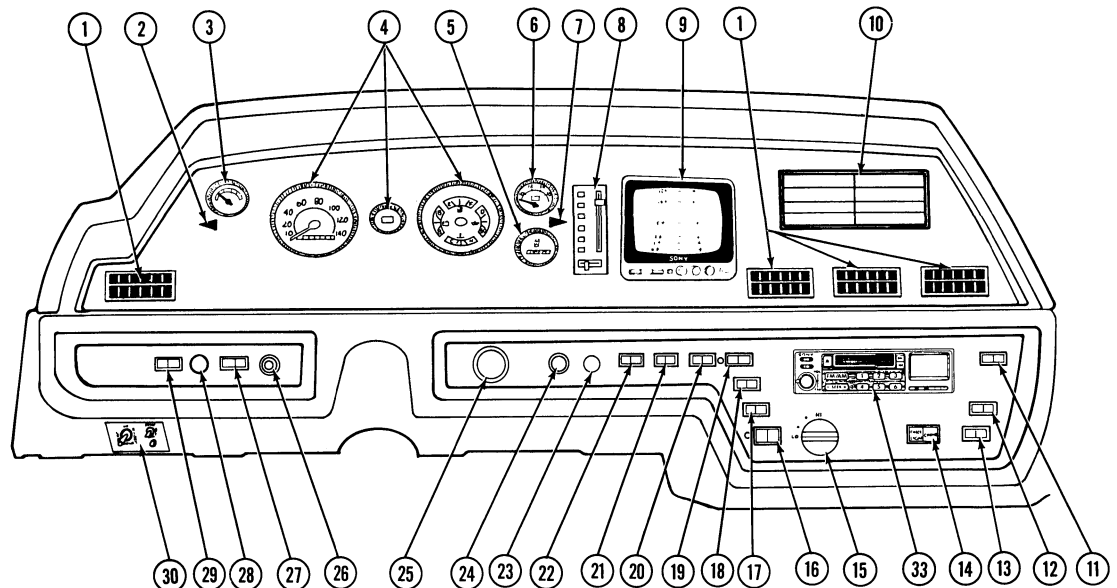

- |                                  |                                  |   |
|----------------------------------|----------------------------------|---|
| 1. Vent/Air Conditioner Register | 11. Courtesy Lights Switch       | 21. Auxiliary Windshield Fan Switch       |
| 2. Left Turn Indicator           | 12. Map Light Switch             | 22. Air Horn Compressor Switch            |
| 3. Vacuum/Fuel Economy Gauge     | 13. Beverage Tray Light Switch   | 23. Low Air Warning Light (Tag Axle Only) |
| 4. Instrument Cluster            | 14. Check Engine/Choke Indicator | 24. Cigarette Lighter                     |
| 5. Auxiliary Generator Hourmeter | 15. Rear Auto Heater Switch      | 25. Ignitor Switch                        |
| 6. Battery Condition Meter       | 16. Auxiliary Battery Switch     | 26. Headlight Switch                      |
| 7. Right Turn Indicator          | 17. Radio Power Switch           | 27. ICC Courtesy Blink Switch             |
| 8. Heater A/C Controls           | 18. Auxiliary Generator Switch   | 28. Leveling Jacks Down Indicator         |
| 9. Rearview Monitor              | 19. Fog Light Switch             | 29. Battery Mode Switch                   |
| 10. Cassette Tape Holder         | 20. Battery Condition Switch     | 30. Remote Flood/Spotlight Control        |

**INSTRUMENT PANEL - Elandan/Windcruiser  
(Chevrolet Chassis - Electronic Instrumentation)**

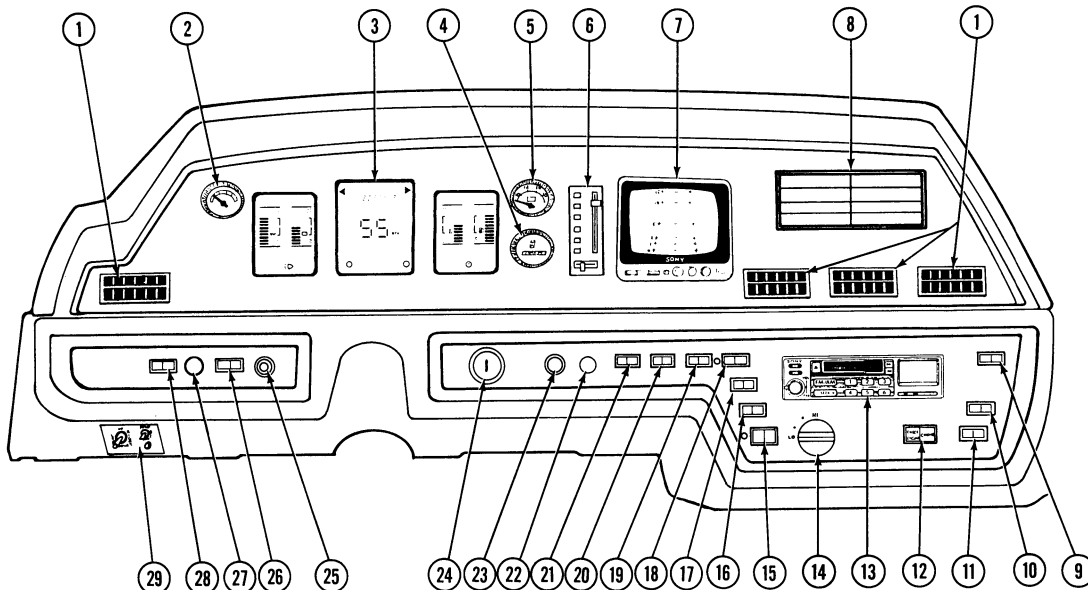

- |                                  |                                     |   |
|----------------------------------|-------------------------------------|---|
| 1. Vent/Air Conditioner Register | 11. Beverage Tray Light Switch      | 22. Low Air Warning Light (Tag Axle Only) |
| 2. Vacuum/Fuel Economy Gauge     | 12. Check Engine/Choke Indicator    | 23. Cigarette Lighter                     |
| 3. Instrument Panel              | 13. Audio Entertainment System      | 24. Ignition Switch                       |
| 4. Auxiliary Generator Hourmeter | 14. Rear Auto Heater Switch         | 25. Headlight Switch                      |
| 5. Battery Condition Meter       | 15. Auxiliary Battery Switch        | 26. ICC Courtesy Blink Switch             |
| 6. Heater A/C Controls           | 16. Radio Power Switch              | 27. Leveling Jacks Down Indicator         |
| 7. Rearview Monitor              | 17. Auxiliary Windshield Fan Switch | 28. Battery Mode Switch                   |
| 8. Cassette Tape Holder          | 18. Auxiliary Generator Switch      | 29. Remote Flood/Spotlight Control        |
| 9. Courtesy Lights Switch        | 19. Fog Light Switch                |   |
| 10. Map Light Switch             | 20. Battery Condition Switch        |   |
|                                  | 21. Air Horn Compressor Switch      |   |

## ELECTRONIC INSTRUMENT PANEL (If Equipped)

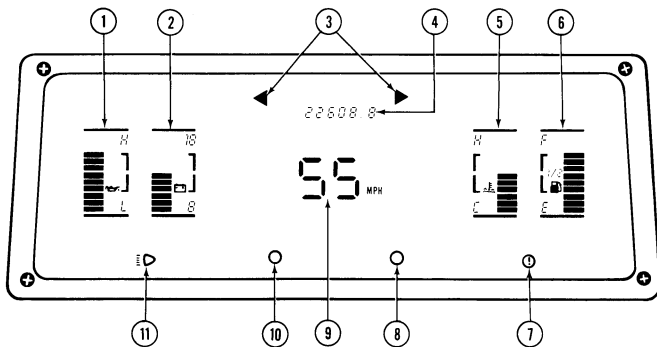

### DISPLAY FEATURES

The digital cluster displays the same information that a standard cluster does, except that it uses fluorescent digital numbers and bar graph gauges to display information, rather than dials and needles.

The dash contains a memory that stores mileage and mode information, so the odometer mileage and MPH-km/h mode will always remain the same as when the vehicle was last driven.

- Oil Pressure Gauge**—Indicates approximate oil pressure while engine is operating. The gauge symbol will blink if oil pressure drops below warning level (approx. 3 bars).
- Battery Voltage Gauge**—Indicates battery voltage from approximately 8 to 18 volts. If voltage drops below 12 volts, the gauge symbol will flash as a warning.
- Turn Signal Indicators**—One of the green arrows will flash to correspond to the direction selected with the turn signal lever. Both arrows flash in unison when emergency warning flashers are activated.
- Odometer**—Displays total vehicle miles traveled in MPH or km/h as selected with the mode selector button (#8). Also displays trip odometer using the trip odometer selector button (#10). A small **t** will appear at the left end of the display to indicate miles traveled since last reset.
- Coolant Temperature Gauge**—Indicates approximate engine coolant temperature in degrees F. The gauge symbol will flash if the coolant temperature exceeds the warning level (approx. 240 degrees F).

- Fuel Level Gauge**—The low fuel warning will begin to flash when the fuel indicator displays less than 1/4 tank (3 bars or less).
- Brake Warning Indicator**—The red brake warning symbol will flash when brakes are applied if there is a loss of hydraulic pressure in either half of the dual braking system.
- MPH-km/h Mode Selector**—Push the lower right-hand button to select the display mode (MPH or km/h) for the speedometer, odometer and trip odometer.
- Speedometer**—Displays vehicle speed from 0-85 MPH or 0-137 km/h as selected with the mode selector button. (See #8.)

Each time the motor home is started, the speedometer will display **188** for a short period to verify proper display operation.

- Trip Odometer Selector/Reset**—To turn the trip odometer function on or off, press and release the lower left-hand button. While the trip odometer function is in use, a small **t** will appear at the left end of the odometer display. To reset the trip odometer, press and hold the button until the display resets to zero (about 2-3 seconds).
- High Beam Indicator**—The blue headlight symbol illuminates when the high beams are selected.

### MULTI-FUNCTION SIGNAL LEVER (Chevrolet A-Body)

The multi-function signal lever controls the turn signals, high/low beam changing, windshield washer, wipers and wiper delay, and the electronic speed control.

#### Headlight Beam Change and Turn Signals

Move multi-function lever upward for right turn signal and downward for left turn signal.

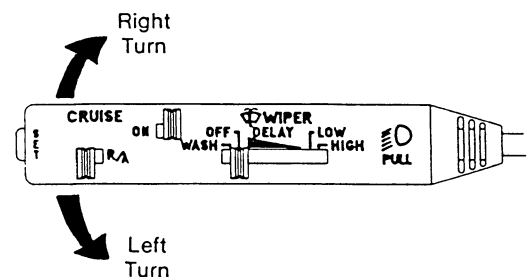

Compress handle to switch high to low beam, or low to high beam.

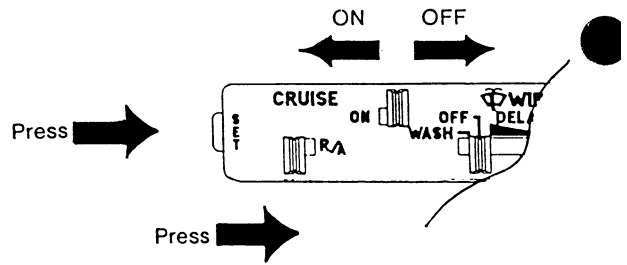
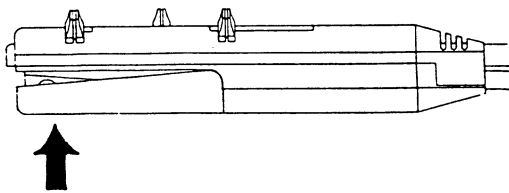

### Windshield Wipers and Wiper Delay

Move slide button from OFF to DELAY; you will get a wipe and a delay between wipes (ranging from 45 seconds to 2 seconds) as slide moves to the right.

A continuous LO speed or HI speed wipe can be obtained by moving slide button to position.

Moving slide button to OFF position stops wipers and puts wiper motor in PARK position.

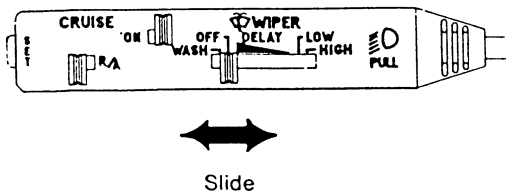

### Windshield Washer

Move slide button to WASH position and release; wash solution is delivered with an approximate five second wipe cycle to follow. A (demand) wash and wipe is performed as long as the WASH button is ACTIVATED.

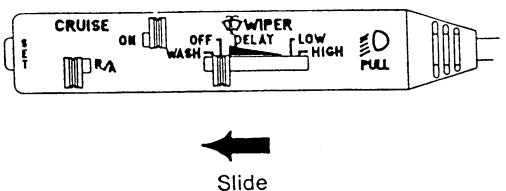

### SPEED CONTROL (CRUISE)

In the regulator box of your Speed Control is a safety switch which will not let the system operate until your vehicle is moving above a pre-selected low speed. At the factory this "low speed switch" is set to close between 27 and 33 mph.

**NOTE:** SET = SET/COAST  
R/A = RESUME/ACCELERATION

**Set Speed**—On the control switch, move the slide button to the ON position and drive at any speed above 32 mph at which you want automatic control. Hold that speed with your foot while you press and release the SET/COAST button. One second after release, take your foot off the accelerator pedal.

You can increase speed at any time with the accelerator pedal. When you release the pedal, you will return to the set speed.

**Acceleration**—Hold the slide button in the RESUME/ACCEL position and your vehicle will accelerate until you release it, then your vehicle will slow to your set speed and again control there.

If you want to make the higher speed your new set speed, release the slide button when you reach the speed you want, and as you do, quickly press and release the SET/COAST button. Remember, you set speed as you release the button—not when you press it.

**Coast**—When you press and hold the SET/COAST button, you erase the set speed from the regulator's memory and allow the vehicle to coast. Just before you reach the lower speed you want, release the button and it will maintain speed there, provided it is above the low speed setting.

**Disengagement**—Depress the brake pedal about an inch and you again are in control of the vehicle speed. You can also disengage the speed control by pushing the slide button to OFF, but this erases the set speed from the regulator's memory.

**Resume**—When you disengage the system with the brake, you do not erase the set speed from the regulator's memory, even if you come to a complete stop. To return to your chosen speed, drive to a speed above 32 mph, then move the slide button to the RESUME/ACCEL position and release it. The speed control will take you back to your set speed and control there.

If the rate of acceleration is faster or slower than you like, drive with the accelerator to a speed close to the set speed, then slide the button to the RESUME/ACCEL position and release it.

**Unusual Conditions**—When the regulator is adjusted right, your selected speed should be held within plus or minus 4 mph so long as grades do not exceed 7% (most interstate highways). Since the speed control is vacuum operated, this speed range will widen as you drive at higher altitudes.

Any opening of the throttle lowers the vacuum to some degree. A wide open throttle can drop the vacuum almost to zero. When you are pulling an extra heavy load, climbing a very steep hill, or bucking a severe head wind, a much wider than normal throttle opening is called for, but this drops the vacuum so low that the throttle is deprived of the strength it needs to hold speed.

The way to handle these occasional problems is to bring the vehicle up to speed with the accelerator pedal and then let the speed control take over again.

## WARNING

Do not use your speed control on slippery roads, or in heavy traffic.

There is no drain on the battery when the ignition switch is off—even if the control switch is left on.

**NOTE:** Before leaving on vacation or a long trip, make a short road test to see that all functions are working. If your speed control does not function as desired above, contact your Winnebago or Itasca dealer or call 1-800-GET-DANA.

## SPEED CONTROL (CRUISE) (Toyota C-Body)

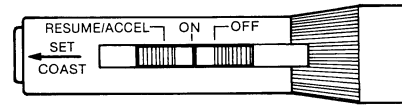

**NOTE:** SET = SET/COAST  
R/A = RESUME/ACCELERATION

**Set Speed**—On the control switch, move the slide button to the ON position and drive at any speed above 32 mph at which you want automatic control. Hold that speed with your foot while you press and release the SET/COAST button. One second after release, take your foot off the accelerator pedal.

You can increase speed at any time with the accelerator pedal. When you release the pedal, you will return to the set speed.

**Disengagement**—Depress the clutch or brake pedal about an inch and you again are in control of the vehicle speed. You can also disengage the speed control by pushing the slide button to OFF, but this erases the set speed from the regulator's memory.

**Resume**—When you disengage the system with the clutch or brake, you do not erase the set speed from the regulator's memory, even if you come to a complete stop. To return to your chosen speed, drive to a speed above 32 mph, then move the slide button to the RESUME/ACCEL position and release it. The speed control will take you back to your set speed and control there.

If the rate of acceleration is faster or slower than you like, drive with the accelerator to a speed close to the set speed, then slide the button to the RESUME/ACCEL position and release it.

**Unusual Conditions**—When the regulator is adjusted right, your selected speed should be held within plus or minus 4 mph so long as grades do not exceed 7% (most interstate highways). Since the speed control is vacuum operated, this speed range will widen as you drive at higher altitudes.

When you are pulling an extra heavy load, climbing a very steep hill, or bucking a severe head wind, a much wider than normal rack (throttle) opening is called for.

The way to handle these once-in-a-while problems is to bring the vehicle up to speed with the accelerator pedal and then let the speed control take over again.

## WARNING

Do not use your speed control on slippery roads, or in heavy traffic.

There is no drain on the battery when the ignition switch is off—even if the control switch is left on.

**NOTE:** Before leaving on vacation or a long trip, make a short road test to see that all functions are working. If your speed control does not function as desired above, contact your Winnebago or Itasca dealer or call 1-800-GET-DANA.

### MULTI-FUNCTION SIGNAL LEVER (All other models)

Consult your vehicle chassis manual for operating instructions.

### REAR WINDOW WIPER (If Equipped)

The optional rear window wiper is controlled by a switch on the instrument panel. Refer to the instrument panel illustration for your model for the specific location of this switch.

## COMFORT CONTROLS

### AUTO AIR CONDITIONER/HEATER (A-Body)

Controls for the air conditioner, heater, defroster and vent are all incorporated into one control panel. Refer to the following instructions for use of individual controls.

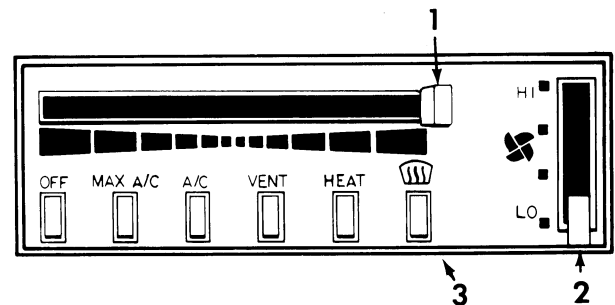

1. Temperature Lever
2. Front Heater Fan Switch
3. Function Switches

### Heating

- A. For maximum heating:
  1. Press the HEAT or VENT mode selection button.
  2. Move the temperature control lever to WARM (red).
  3. Place the fan switch to HI.
- B. For reduced heating:
  1. Move the temperature control lever to the left to an intermediate setting.
  2. Adjust the fan speed for desired volume.

### Defrosting

- A. For maximum defrosting and defogging:
  1. Press the DEF mode selection button.
  2. Move the temperature control lever to WARM (red).
  3. Place the fan switch in HI.



B. For reduced defrosting:

1. Move the temperature control lever to the left to an intermediate setting.
2. Adjust the fan speed for desired volume.

**Ventilation**

- A. To vent outside air into the vehicle when neither heating or cooling is required:
1. Press the VENT mode selection button.
  2. Move the temperature control lever to COOL (blue).
  3. Adjust the fan speed for desired volume.

**Air Conditioning**

- A. For maximum cooling:
1. Press the MAX A/C mode selection button.
  2. Move the temperature control lever all the way left to the COOL (blue) position.
  3. Place the fan speed switch in HI.
- B. For reduced cooling:
1. Set the fan speed to a lower setting and/or move the temperature control lever toward a warmer setting.
- C. The A/C mode selection button offers cooled outside air at a slightly reduced capacity.

**Off**

When no heating, cooling or defrosting are required:

1. Press the OFF mode selection button. This will shut off the fan and prevent outside air from entering the unit.

**IMPORTANT**

The automotive air conditioner is not designed to cool the entire interior of the motor home, but is intended to cool the driver's compartment only.

**Rear Auto Heater**

To provide auxiliary heat to the rear area of the vehicle, turn the rear heater fan switch to the desired speed.

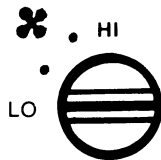

**AUTOMOTIVE AIR CONDITIONER (C-Body, Chevrolet-Gas Engine Only)**

The air conditioner is controlled by two separate knobs located above the heater control panel. The "Air" knob controls fan speed while the "Temp" knob controls cooling temperature. The "Air" knob provides three fan speeds which are obtained by rotating the knob clockwise. Rotating the "Temp" knob clockwise produces colder air temperature. For maximum cooling, turn the "Air" knob to the high position and the "Temp" knob to the coldest position.

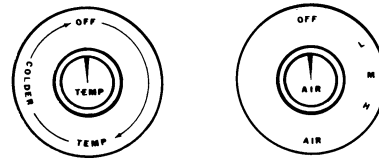

**IMPORTANT**

The automotive air conditioner is not designed to cool the entire interior of the motor home, but is meant to cool only the driver's compartment.

**AUDIO ENTERTAINMENT SYSTEMS**

Most vehicle models are available with optional or standard audio entertainment systems that provide high quality stereo sound for your traveling and living enjoyment. Refer to your Motor Home Operation Manual for operating and care instructions.

**CAUTION**

If your radio is equipped with an electronic tuning receiver, disconnect the radio power leads before attaching a battery charger or jumper cables to the battery. The radio tuner may become damaged if this is not done.

**RADIO SWITCH**

The radio switch allows you to connect the auto radio to the coach batteries for operation while parked, with the ignition switch off. This prevents accidental draining of the automotive (starting) battery by the radio.

### **VACUUM-FUEL ECONOMY GAUGE—Optional (Gas Engine A-Body Only)**

This gauge provides a guide to efficient engine operation. It is impossible to specify an ideal gauge reading, as this will vary a great deal according to operating conditions. However, as a general rule, a high reading usually indicates the most efficient engine operation and the best fuel economy. The vacuum level will be high at idle speed, and as speed and load increase, the vacuum level will drop. To obtain maximum fuel economy, operate the motor home in such a way as to maintain vacuum level as high as possible.

### **BATTERY CONDITION METER AND SWITCH**

See related item under “Battery Information” in Electrical section.

### **BATTERY MODE SWITCH (DUAL-MOM.)**

See related item under “Battery Information” in Electrical section.

### **AUXILIARY BATTERY SWITCH—Optional**

See related item under “Battery Information” in Electrical section.

### **AUXILIARY GENERATOR SWITCH**

See related information under “Auxiliary 110-Volt Generator” in Electrical section.

### **AUXILIARY GENERATOR HOURMETER**

See related information under “Auxiliary 110-Volt Generator” in Electrical section.

### **MAP LIGHT**

The map light is mounted above the windshield on a flexible shaft. A master ON-OFF switch is located on the instrument panel. A switch is also located on the light, and is operated by slightly rotating the rounded rear section of the light. (This switch operates only while the master switch is on.)

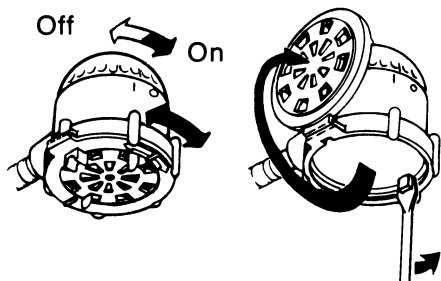

Light intensity may be adjusted by slightly rotating the face bezel of the light, which opens or closes a set of apertures. If full intensity lighting is desired, the face bezel may be hinged open and snapped to the side of the light.

To replace a burned out bulb, carefully pry the lens out of the light using a coin or small screwdriver against the small tab on the lens. Always replace a bulb with one of the same type and size.

### **MAP LIGHT**

The aircraft style map lights are mounted overhead in the driver compartment. Each light may be swiveled to the desired lighting position. Individual switches for each light are located on the base of the light. A master switch, labeled “Map Light” is located on the dash.

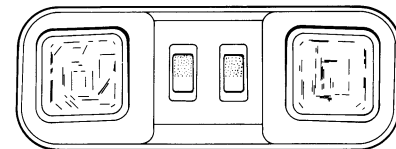

If you wish to control the lights from the dash, leave the individual switches on and use only the dash switch.

### **BEVERAGE TRAY LIGHT**

#### **(Elandan/Windcruiser/Chieftain/Sunflyer)**

The beverage tray on the engine cover contains a small light for nighttime convenience. The switch for this light is located on the instrument panel to the right of the radio/cassette player.

### **COURTESY LIGHTS (Elandan/Windcruiser)**

The courtesy lights are located near the floor of the driver's compartment ahead of the cab doors and illuminate while the cab doors are open. The switch, located on the instrument panel, allows you to turn the courtesy lights on while the doors are closed.

### AISLE FLOOR LIGHT SWITCH

The aisle light is mounted near the floor. The aisle light may be controlled using the switch at the entrance door or by a second switch (if equipped) on the dash.

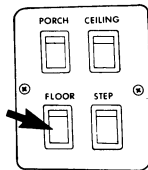

### AUXILIARY FAN SWITCH

If your vehicle is equipped with auxiliary defrost fans, a switch is located on the instrument panel.

### ICC COURTESY BLINK SWITCH

May be used to momentarily blink clearance lights off and on when meeting another Winnebago/Itasca owner, for example, or anyone else you wish to greet in this manner. This function is also helpful in signaling to truckers when they may safely pull back into the lane after passing you. To use, press the right side of the switch momentarily and release. This switch will operate only while the headlight switch is in either the "Park" or "Headlight" position.

### AIR HORNS—Optional

A switch located on the instrument panel activates the optional air horn system. While this switch is on, the air horns are sounded using the steering wheel horn button. When the switch is turned off, only the standard horns will sound.

**NOTE:** Since air horns are extremely loud, it is recommended that you deactivate them while driving in areas where noise abatement ordinances may be in effect.

A 50-foot air hose is also supplied with the vehicle if equipped with air horns. The hose may be connected to the air horn compressor in the engine compartment and used to inflate beach equipment, air mattresses, tires, etc.

### COACH LEVELING SYSTEMS

Coach leveling systems are designed to diminish site selection problems, making "set up" at a camping site faster and more convenient for you.

### IMPORTANT

When parking at an uneven site, always park the front of the motor home to the downhill side. This allows you to level by raising the front end rather than the rear. Since only the rear wheels are locked while in PARK, raising the rear wheels off the ground could allow the vehicle to roll off the jacks.

### HYDRAULIC LEVELING SYSTEM (HWH®)

The leveling system control panel is located on the floor to the left of the driver's seat. Each of the four leveling units (jacks) is controlled by its own lever.

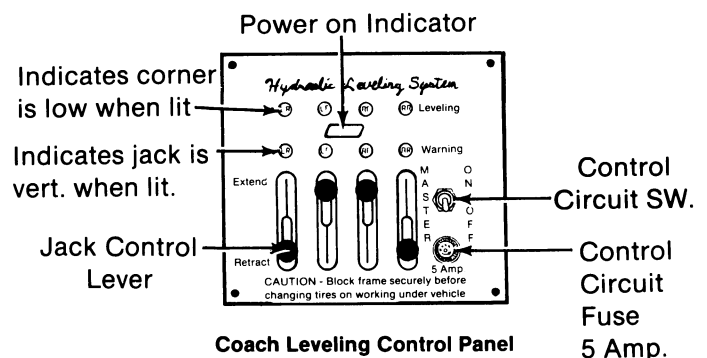

### To Level the Motor Home:

1. Be sure the vehicle is in PARK and the parking brake is applied.
2. Turn the Master switch ON.
3. Operate the jack levers alternately, beginning with the front leveling units, until all of the lights on the lever control panel are off, indicating that the vehicle is level.
4. Turn the Master switch off.

### AIRLIFT SENSORIDE™ SUSPENSION SYSTEM

#### OPERATING INSTRUCTIONS

##### Normal Driving Mode

**Without Park & Level™**—No special instructions or precautions must be observed since the system is always in road travel mode.

**With Park & Level™**—The red Auto/Manual switch should be placed in the Automatic (up) position before driving off. The switch handle emits a red light to alert the operator when the system is in the Park & Level™ (Manual) mode.

The optional Park & Level™ system incorporates electronic air distribution controls for vehicle leveling purposes. It allows air spring pressure to be manually adjusted up-and-down or side-to-side to simulate the function of a hydraulic leveling system. This provides the vehicle owner with a reasonable degree of flexibility in parking/camping site selection.

### CAUTION

Do not drive the vehicle with the Auto/Manual Switch in the Manual position (red handle lit). Damage to suspension components could result.

**NOTE:** Automatic leveling is deactivated when the ignition is switched off. Therefore, it is possible for the vehicle to appear “jacked up” in the rear under certain circumstances.

An example situation would be if several people were occupying the rear of the coach while the ignition is switched off. The height control valves would be compensating for the extra load at the time of power down by adding air pressure to the springs. When the ignition is turned off, the additional air remains inside the springs. When the occupants exit the coach, thereby subtracting the excess weight from the rear, the rear of the vehicle rises.

This is not a malfunction and should be no cause for alarm. When the vehicle is restarted, the automatic leveling system will immediately correct this situation.

### Park & Level™ Controls

The optional Park & Level™ control panel is located at the lower left-hand side of the dash. It contains 3 toggle switches and a compressor indicator light.

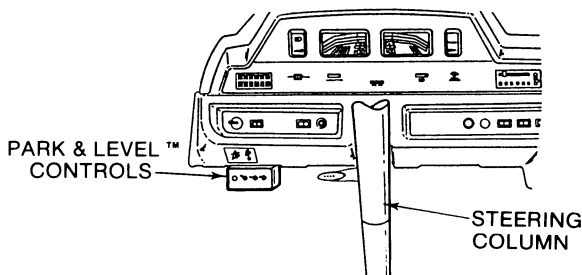

### Leveling

Flip the red toggle switch to “Manual.” The switch will illuminate to indicate that the leveling feature is activated. Level the vehicle by operating the black switches.

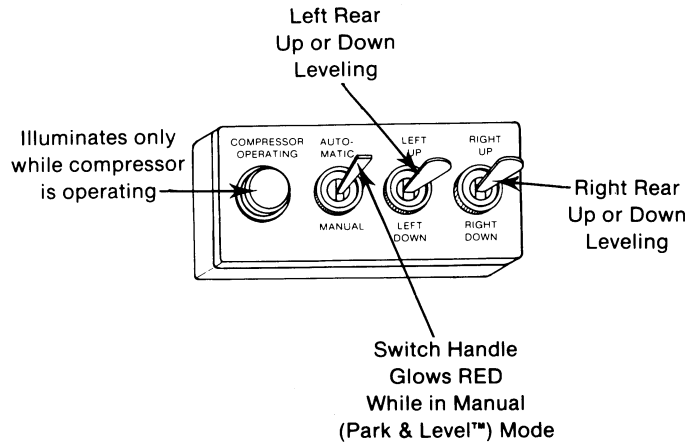

- When raising the rear of the vehicle, operate **both** springs at the same time to provide maximum lifting power.
- When parked on a side hill, raise both springs as mentioned above, then lower the spring on the “uphill” side until the vehicle is level.
- When you’re ready to drive off, switch the mode to “Automatic.” The springs will automatically be adjusted for road travel.

### Compressor Light

The red indicator light labeled “Compressor Operating” will illuminate only while the compressor is operating. When air pressure depletes to a preset minimum amount, the compressor will operate until maximum pressure is restored.

The compressor normally operates periodically while driving to maintain air pressure in the system. It will also operate for a few minutes after starting the vehicle and switching the Auto/Manual switch back to “Automatic” (when Park & Level™ has been in use) to restore air pressure released during leveling.

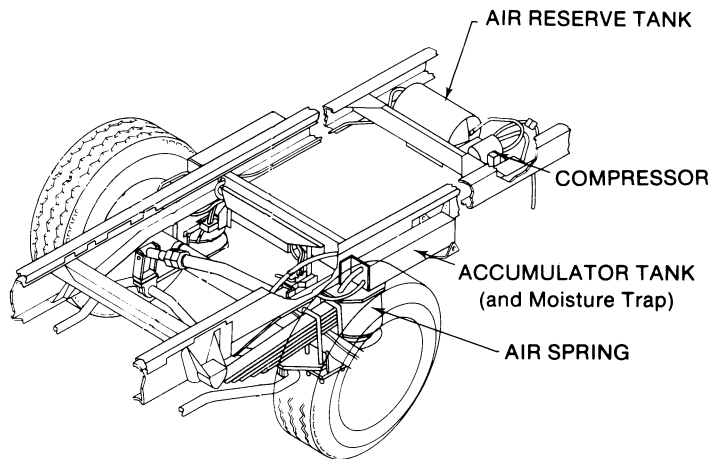

### Periodic Maintenance

There are very few items on this suspension system that require periodic maintenance. Here are a few simple maintenance suggestions:

- Purge moisture from air reserve and accumulator tanks before freezing temperatures and/or vehicle storage. Turn the butterfly valve on the bottom of each tank 90° to expel water. Close the valve when water stops spraying from the valve.
- Periodically inspect air springs for cracks that could develop into rips or holes.
- Periodically inspect air hoses for abrasions, pinholes or other conditions which could result in air leaks.
- Pressure wash underside of vehicle periodically to avoid build-up of mud on suspension components, which can prematurely wear moving parts.

1. [Illegible]  
2. [Illegible]

OCT 31 1989

## SECTION 3 IN CASE OF DRIVING EMERGENCY

### HAZARD WARNING FLASHER

The hazard warning flasher provides additional safety when the vehicle must be stopped on the side of the roadway and presents a possible hazard to other motorists. When the flasher is on, it serves as a warning to the other drivers to approach and overtake your vehicle with caution.

#### WARNING

Operating the hazard warning flasher system while moving on the highway is illegal.

The front directional signals and the taillights will flash intermittently when the flashers are in operation. The hazard warning flashers will not operate when the service brake pedal is depressed. The turn signal will not operate when the flashers are on. When it is necessary to leave the vehicle, the flasher system will continue to operate with the ignition key removed.

### IF YOU GET A FLAT TIRE

In case of sudden tire failure, avoid heavy brake application. Gradually decrease speed. Hold steering wheel firmly and move slowly to a safe, off-road place. Park on a level spot, turn off the ignition, and turn on the hazard flasher system.

#### Spare Tire Storage

##### All Models except Sunflyers:

The spare tire is located on the rear of the vehicle or in the rear "trunk" compartment.

##### Sunflyers except Model 25RC:

The spare tire is stored in the passenger side rear cargo compartment.

#### Sunflyer 25RC Only:

The spare tire is mounted on a hoist assembly beneath the rear of the vehicle as shown in the illustration.

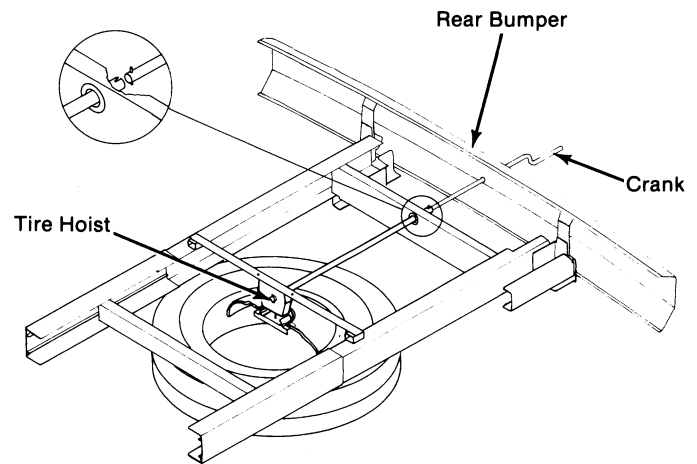

Top View of Chassis

#### To Access Spare:

1. Insert the crank handle through the hole in the rear bumper. Be sure the pins on the crank handle engage with the slots in the hoist shaft (see inset).
2. Turn the crank handle counterclockwise to lower the tire to the ground.
3. Remove the spare from the carriage plate by passing the plate through the large center hole of the wheel.

#### To Stow Spare:

1. Insert the carriage plate through the wheel and align so the retainers will engage into the center hole of the wheel.
2. Insert the crank handle into the rear bumper and crank clockwise to raise the tire up. Check to see that the carriage plate is firmly engaged in the center hole of the wheel as the cable becomes taut.
3. When the tire makes snug contact with the frame, crank the handle an additional 1/2 turn to lock the hoist into position. Remove and stow the crank handle.

## MOTOR HOME JACKING AND TIRE CHANGING PROCEDURE

### IMPORTANT

The jack referred to in the following instructions is not supplied with the vehicle and must be obtained by the owner from the selling dealer.

A jack is designed for use as a tool for changing tires only, not for use as a leveling device or as a support for service purposes.

### WARNING

Tire change procedures should be used in emergency situations only. The operator is advised to obtain qualified road service when possible.

### SAFETY PRECAUTIONS

Before attempting to change either the front or rear tires, the following precautions should be adhered to:

1. Park vehicle on level surface only.
2. Turn off engine and set parking brake.
3. Activate hazard warning flasher.
4. Block both front and back of wheel opposite wheel to be removed.
5. On soft ground, use a board or other material under jack as a firm base to ensure that the jack will not shift.

### JACKING POINT ON VEHICLE

MODELS	FRONT	REAR
All	Lower Control Arm	Under Axle Housing Near Wheel to be Raised

### Front Wheel

Before attempting to remove the front wheel, observe the above safety precautions, then initiate the following procedures:

1. Turn the jack extension out to approximately ground to spring height.
2. Position jack under lower control arm.

**NOTE:** Lower control arm base must be supported by the jack. Begin jacking until the jack is firmly positioned, but do not jack tire off the ground.

3. Loosen wheel nuts with lug wrench.
4. Resume jacking until wheel is free of ground.
5. Remove wheel nuts and wheel; put spare wheel in place.
6. Install wheel nuts and tighten as much as possible with wheel and tire off the ground.
7. Lower tire until tire just contacts the ground. Tighten nuts with lug wrench in sequence recommended by chassis manufacturer.
8. Finish lowering jack, remove jack and blocks.

### WARNING

Upon satisfactory completion of emergency tire change, it is highly recommended that wheel nuts be properly torqued and inspected by qualified service personnel as soon as possible.

### Dual Rear Wheels

Before attempting to remove the rear wheel, follow safety precautions in the beginning of the motor home jacking procedures and then initiate the following procedures:

1. Turn jack extension out to approximate ground axle housing tube height.
2. Place jack under axle housing near wheel to be raised. Center jack on the housing so vehicle will not slide off jack. Place jack far enough inboard on the axle housing so that when the handle is inserted, the jack may be operated from either in front or behind the tire without crawling under the vehicle.
3. Begin jacking, but **DO NOT** lift wheel and tire off the ground.
4. Loosen wheel nuts with lug wrench.
5. Resume jacking until wheel and tire are free of ground.

**NOTE:** Full torque must be applied to dual rear wheel nuts with both wheels off the ground.

### WARNING

**DO NOT** crawl under the vehicle when it is supported by a jack.

6. Remove wheel nuts and wheel.

## IMPORTANT

When installing the outboard wheel and tire assembly, rotate the wheel so that an outboard wheel cutout, without the tire valve, is opposite the inboard wheel tire valve.

NOTE: When installing or tightening dual wheels, both wheels on the same side must be off the ground (not resting on the inner dual). This minimizes the possibility of loose wheels after correct mounting torque is applied.

7. Mount spare wheel on studs and replace wheel nuts. Refer to your vehicle chassis manual for wheel nut torque and tightening sequence.

### Wheel Nuts

To properly seat the wheel nuts and to eliminate the possibility of the wheel nuts becoming loosened while driving, they should be tightened at frequent intervals to the torque specified in your vehicle chassis manual. This is especially important during the first 100, 1,000 and 6,000 miles of operation after replacement of a wheel or wheel nuts.

## WARNING

The operator is advised to obtain road service whenever possible and attempt tire changing under emergency conditions only and with close adherence to instructions. If it becomes necessary to change a wheel, that wheel should be checked, after being properly torqued and inspected by qualified service personnel, at 100 miles and every oil change thereafter.

Upon satisfactory completion of emergency tire change, it is highly recommended that the wheel nuts be properly torqued and inspected by qualified service personnel as soon as possible.

## WARNING

Do not use wheel nuts intended for aluminum wheels to mount the steel wheel spare tire. These nuts will not seat properly on steel wheels. Use only the wheel nuts and steel clamp ring provided with the spare tire for mounting.

### RECOVERY TOWING

These instructions are intended to aid the towing operator in preparing the motor home. Correct preparation is necessary to avoid damage to motor home body and chassis components.

Winnebago does not assume responsibility for damage incurred while towing this vehicle.

NOTE: Always consult the chassis operating guide for any additional towing instructions by the chassis manufacturer.

### C-Body Vehicles

See chassis operating guide for proper recovery towing procedures.

### A-Body Vehicles with Osh Kosh Chassis

Due to the automatic parking brake feature on this chassis, special towing procedures must be followed.

See "Towing" in Osh Kosh chassis operating guide for recovery towing instructions. Front bumper removal may be required depending on method of towing.

### A-Body Vehicles with Chevrolet or Ford Chassis

1. Remove front bumper or soft bumper facia, depending on model. Some models may also require removal of bumper mounting brackets.

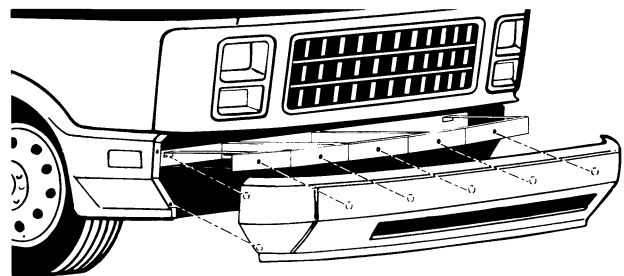

Front Bumper Removal



## CAUTION

Do not lift on bumper. Damage will result to front body components.

2. Attach tow hooks where they cannot damage brake lines or suspension or steering components.
3. ELANDAN, WINDCRUISER & SUNFLYER: Place a 4" x 4" (minimum) wooden or metal beam beneath the forward extension channels ahead of the steel tube crossmember as shown.

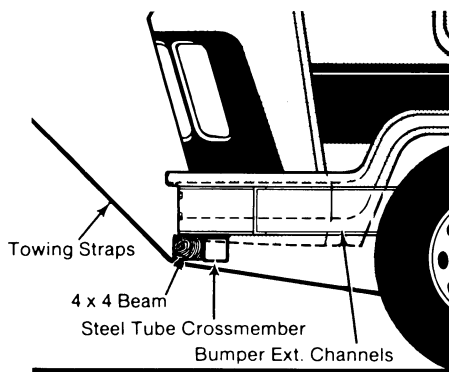

TOWING ATTACHMENT  
(Elandan, Windcruiser & Sunflyer)

CHIEFTAIN, SUPERCHIEF, SUNCRUISER, WARRIOR (Class A) & SPIRIT (Class A): These models do not have the steel tube crossmember.

- a. Position a 6" x 6" (minimum) beam beneath the original chassis rails just behind the forward chassis extensions.
- b. Then place a 4" x 4" beam beneath the extensions ahead of the automotive battery tray as shown below.

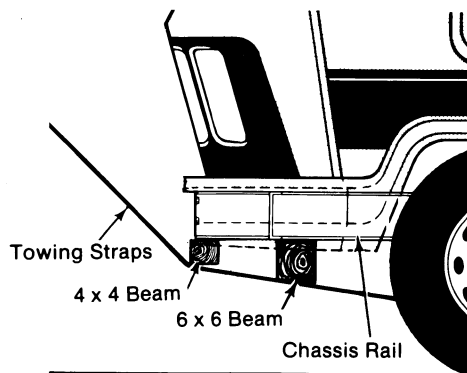

TOWING ATTACHMENT  
(Chieftain, Superchief, Suncruiser, Warrior & Spirit)

4. Be sure towing straps, cables or chains do not touch grille or front body shroud.
5. Use a safety chain system that is completely independent of the primary lift/tow assembly.
6. Secure any loose or protruding parts of damaged vehicle before towing.

## WARNING

Stay out from beneath the motor home while it is suspended by the towing assembly unless the vehicle is adequately supported by safety stands. Do not allow passengers to occupy a towed vehicle.

## IMPORTANT

Know and obey all state and local towing regulations. Tow at reduced speed.

## JUMP STARTING

## WARNING

Automotive batteries produce caustic acid, explosive gases and electrical current which may cause burns. It is important that the instructions below are followed **exactly**, or personal injury (particularly to eyes) or property damage may result due to battery explosion, battery acid, or electrical (short circuit) burns.

- NEVER smoke near the battery or expose it to open flame or electrical sparks.
- Wear eye protection or shield your eyes while working near either battery, in case an explosion does occur. NEVER lean over a battery.
- Do not allow battery fluid to contact eyes, skin, clothing, or painted surfaces. Immediately flush any contacted area with water. If eyes are affected seek medical help after flushing.
- Remove all metal jewelry to lessen the risk of a short circuit occurring.

### Connecting Jumper Cables

1. Make sure that the other vehicle has a 12-volt battery and negative ground compatible with your vehicle's electrical system.
2. Position the vehicle with the good battery so that the jumper cables will reach, but **do not allow the vehicles to touch.**
3. Turn off all electrical accessories, motors, and lights except those required for safety or to illuminate the work area. Place automatic transmission in P (Park). Be sure parking brakes are engaged in both vehicles.
4. If the discharged battery has filler caps, make sure the electrolyte is at proper level. Add distilled water if fluid is low. If electrolyte is not visible or appears to be frozen—**do not attempt jump starting!** A battery may rupture or explode if the electrolyte is frozen or not filled to the proper level.
5. Connect one end of the positive “+” (red) jumper cable to the positive “+” terminal of the discharged battery. Connect the other end to the positive “+” terminal of the charged battery.
6. Connect one end of the negative “-” (black) jumper cable to the negative “-” terminal of the charged battery.
7. Finally, connect the remaining end of the negative “-” (black) cable to a solid, metal grounded location on the engine of the vehicle with the weak battery at a point at least 18 inches from the battery.  
Do not connect to any moving parts.  
**THE PRIMARY SAFETY PRECAUTION IS TO MAKE THE FINAL CONNECTION TO GROUND ON THE ENGINE AT A SAFE DISTANCE FROM THE BATTERY. THIS HELPS TO REDUCE THE CHANCE OF EXPLOSION DUE TO SPARKS.**
8. Start the engine of the vehicle with the charged battery, and allow it to run for a few minutes at moderate r.p.m. Then start the engine of the vehicle with the discharged battery.
9. Reverse the above sequence **EXACTLY** when removing the jumper cables. Start by removing the cable from the ground location on the engine first, then continue in reverse sequence.

### WARNING

Do not attempt to push-start this vehicle. Damage to the transmission or other parts of the vehicle could occur.

### CONNECTING A BATTERY CHARGER

#### CAUTION

Disconnect the radio power leads before attaching a battery charger or jumper cables to the battery. The radio tuner may become damaged if this is not done.

To connect a battery charger, first make sure the engine is switched off. Disconnect the positive lead from the battery. Never disconnect the battery while the engine is running or alternator damage could result.

Connect the positive “+” (red) lead of the charger to the positive “+” terminal on the battery. Next, connect the negative “-” (black) lead of the charger to a suitable ground. Finally, plug in or switch on the charger.

To disconnect the charger after charging, unplug the charger from the electrical outlets, remove the charger leads from the vehicle, and reconnect the vehicle leads to the battery.

### ENGINE OVERHEAT

If you see or hear steam escaping from the radiator or the engine compartment or have any other reason to suspect an extreme engine overheating condition, pull the vehicle over to the roadside as soon as it is safe to do so, stop the engine and get out of the vehicle.

#### WARNING

Operating a vehicle under a severe overheating condition can result in damage to the vehicle and may result in personal injury.

An engine will overheat if the coolant is low or there is a sudden loss of coolant because of one or more of the following:

- a slow leak in the cooling system
- a hose failure
- a drive belt breaking
- water pump failure.

Also, be aware of the following situations, which can cause temporary engine overheating:

- climbing a long hill on a hot day
- idling while stopped in traffic for long periods of time
- towing a trailer or automobile
- stopping after a period of high speed driving

If the TEMP indicator on the instrument panel shows a rise in engine coolant temperature while driving, take the following steps to attempt to lower the overheating condition:

- If you are using the automotive air conditioner, turn it off.
- If you are stopped in traffic, shift the transmission into P (Park), and engage parking brake.

If the temperature does not drop within a minute or two:

- Pull the vehicle over to the roadside as soon as it is safe to do so.
- Place the transmission in P (Park) and press the accelerator to increase engine speed (r.p.m.'s) to twice that of normal idle speed, and hold it there for approximately two or three minutes.
- If engine temperature does not go down, turn the engine off and wait until the engine has cooled before attempting to open the hood.

When no trace of escaping steam is heard or seen, open the hood to check for the cause of the overheat. Check hose connections and tighten if necessary. Make sure there are no broken belts, pulleys or hoses before adding any coolant to the radiator.

For further information in a case of overheating consult your vehicle chassis manual.

100-100000-00  
100-100000-00  
OCT 31 1989

## SECTION 4

# TRAVELING WITH YOUR MOTOR HOME

(See also SAFETY PRECAUTIONS, Section 1 of this manual.)

### LOADING THE VEHICLE

When loading the vehicle, distribute the cargo load equally so that you do not exceed either the Front or Rear Gross Axle Weight Rating (GAWR) or the Gross Vehicle Weight Rating (GVWR). Have your vehicle weighed to determine the proper load distribution for your vehicle. The GVWR is listed on the Vehicle Certification Label.

The total combined weight allowed for the vehicle, including trailer towing load weight, is known as the Gross Combined Weight Rating (GCWR). If trailer towing is not recommended, the GCWR will be equal to the GVWR.

Your cargo capacity will vary according to the options equipped on your vehicle and your additional equipment and components not supplied with the vehicle. **Do not exceed** any of the recommended weight ratings.

**NOTE:** We recommend that you dump all holding tanks before traveling to avoid carrying unnecessary weight.

### CAUTION

The weight of the loaded vehicle (including options, attachments, passengers, water, fuel, luggage and all other cargo) must not exceed the GVWR or the GAWR of either axle.



**Rear GAWR**  
(Rear Axle Only)



**Front GAWR**  
(Front Axle Only)



**GVWR**  
(Both Axles)

### WEIGHING YOUR MOTORHOME

We recommend that front suspension and steering alignment be checked and adjusted if necessary after you have fully loaded the vehicle according to your needs. Thereafter, alignment should be periodically inspected to maintain vehicle steering performance and to prevent uneven tire wear.

### ROOF LOADING

The roof on most models is capable of carrying some lightweight articles while the vehicle is in motion. A roof-mounted luggage carrier designed for this purpose is available from your dealer. However, maximum roof load while the vehicle is in motion is not to exceed 10 pounds per square foot or a maximum of 100 pounds.

When the vehicle is stationary, a cargo load of 100 pounds plus the weight of a 225 pound person to load the cargo or to conduct inspection and maintenance is permissible.

Weight added to both the roof and the trailer hitch contribute to the gross vehicle weight, which must not exceed the vehicle's GVWR.

### TRAILER TOWING

Vehicles which are equipped with factory installed trailer hitches have a towing capacity label affixed to the rear of the vehicle.

### TOWING CAPACITY

TOWED VEHICLE	*	LB. GROSS MAXIMUM
HITCH BALL	*	LB. MAXIMUM

\*SEE THE LABEL ON YOUR VEHICLE FOR WEIGHT LIMITATIONS.

Because of individual vehicle use and loading habits, we recommend weighing the vehicle while fully loaded to avoid exceeding any of the listed Gross Weight Ratings. Refer to the illustration "Weighing Your Motor Home" on page 4-1. See "Vehicle Certification Label" for information on gross weight ratings.

Towing will affect handling, durability and economy. Exceeding any of the listed Gross Weight Ratings will result in unacceptable overall vehicle performance. Maximum safety and satisfaction when towing depends on proper use of correct equipment.

Installation of a proper trailer brake system is recommended. Check state regulations concerning trailer weight and trailer brake requirements to ensure selection of suitable equipment before attempting to tow.

Before descending a steep or long grade when towing a trailer, reduce speed and shift into a lower gear to control vehicle speed. Avoid prolonged or frequent application of the brakes which could cause overheating.

### WARNING

For safe towing and vehicle handling, maintain proper trailer weight distribution.

The total weight of the motor home and the vehicle towed must not exceed the Gross Combined Vehicle Weight rating. Contact the chassis manufacturer to obtain the Gross Combined Vehicle Weight rating for your chassis.

### CAUTION

Exceeding any of the recommended gross weight ratings may result in vehicle damage.

Do not install a frame equalizing type hitch on your vehicle.

### PRE-TRAVEL CHECK LIST

Before starting the engine in preparation for an outing, be sure your motor home has been properly prepared and maintained. This will ensure an enjoyable trip and help avoid delays. Use this checklist as a guide.

- \_\_\_ Fluid Levels—Check and fill if necessary; engine oil, transmission, power steering, radiator, brake, battery and windshield washer.
- \_\_\_ Wheel Lug Nuts—Check for tightness.
- \_\_\_ Tires—Check for proper cold inflation pressures as specified on the Vehicle Certification Label.

\_\_\_ Drive Belts—Check for proper condition and tension (not cracked, frayed or loose, etc.).

\_\_\_ 110-Volt Generator (Optional)—Check oil level in generator engine.

### WARNING

Never check oil level in generator while engine is operating.

- \_\_\_ Fire Extinguisher—Make sure it is fully charged and secured in mounting bracket.
- \_\_\_ Lights—Make sure all exterior lights operate.
- \_\_\_ Sewer and Water Supply Hose—Unhook and store.
- \_\_\_ TV Antenna—Make certain the TV antenna is lowered and seated in its support cradle.
- \_\_\_ Loose Items Inside the Motor Home—Store or secure items.
- \_\_\_ Pilot Lights—Make sure all pilots are off.
- \_\_\_ Fuel Tanks—Check level.
- \_\_\_ Water Tank—Fill with fresh water.
- \_\_\_ Exterior Door and Step—Make sure doors are closed, locked and step retracted.
- \_\_\_ Seats—Adjusted for comfortable position and locked in place.
- \_\_\_ Mirrors—Adjust for maximum visibility from driver's seat.

### EQUIPPING FOR TRAVEL

When beginning a trip, several items should be taken in addition to the basic clothes, food and recreational items. A checklist is provided for your convenience. Remember, it is important to distribute weight and store all heavy items near the floor.

## EMERGENCY EQUIPMENT CHECKLIST

Flashlight  
First Aid Kit  
Road Emergency Flares  
Tool Box with Assortment of Hand Tools  
Plastic Bucket  
Tow Chain or Rope  
Wheel Blocks for Leveling or Extra Jacks  
Water Hose  
100-150 Feet of 3 Wire Electrical Cord with at least 30 AMP Capacity  
Fire Extinguisher  
Hydraulic Jack and Lug Wrench  
Spare Tire

## QUICK LOADING CHECKLIST

### LINENS

Sleeping Bags  
 Sheets  
 Pillow Cases and Pillows  
 Mattress Pads  
 Extra Blankets  
 Laundry Bags

### COOKING

Can Opener  
 Bottle Opener  
 Aluminum Foil  
 Matches  
 Plastic Bags  
 Coffeepot  
 Storage Dishes

### CLEANING

Scouring Pads  
 Cleanser  
 Glass Cleaner  
 Dish Soap  
 Sponge  
 Laundry Soap  
 Cleaning Rags or Paper Towels  
 Garbage Bags

### BATHROOM

Bath/Hand Soap  
 Bath Towels that can double as beach towels  
 Toiletry Kits  
 Toothbrushes and toothpaste  
 Shaver  
 Toilet Tissue (RV)

### BABY NEEDS

Car Seat (Child Restraint)  
 Porta-Crib  
 Play Pen

## PERSONAL

Credit Card  
 Traveler's Checks  
 Money  
 Driver's License  
 Proof of Citizenship for Canadian or Mexican Crossing  
 Sunglasses

## PET NEEDS

Food  
 Leash  
 Water and Food Dishes  
 Proof of Rabies Shot

## MISCELLANEOUS

String  
 Clothesline  
 Insect Repellent  
 Masking Tape

## TRAVEL TIPS

As you travel around the country in your motor home, you will pick up various tips from other motor home owners.

A number of tips can also be picked up by reading articles and regular columns in some of the outdoor and camping magazines. Some magazines and publishing companies print an annual park and campground directory. These can be found at your local newsstand or RV supply dealer. Following are just a few travel tips to start out with.

1. Always check for sufficient clearance. Remember the height and width of your unit.
2. Taste the water before filling the water tank in an unfamiliar location. The water in some areas may contain an undesirable taste. Do not use a new hose to fill the water tank. It can leave a distinct rubber or vinyl taste.
3. Showers can take a lot of water. Conserve water by taking a "SEA SHOWER." This is done by: wetting down, turning off the water, soaping thoroughly and then rinsing.
4. Dump sewage only at approved dumping stations.
5. Store liquids in plastic containers with tight fitting caps to prevent spills.
6. Keep an eye on the water and holding tank levels. It is a good idea to dump the holding tank at least every two days.

7. When traveling with children, it is helpful to plan their wardrobe for a week. Place each day's clothing in a plastic bag and label the bag with the child's name and day of the week for use.
8. Use sleeping bags whenever possible. They save laundry and take up less storage space than bedding.
9. Make sure all compartment doors have been closed and the door step has been stowed in the correct position before moving the vehicle.
10. Before traveling, make sure the refrigerator door has been secured. Use care when opening the refrigerator door after the vehicle has been stopped. Any articles that have shifted may fall out when the door is opened.
11. During peak tourist season and holidays, it is best to phone ahead and make reservations at the park where you plan to stop.
12. Some states or cities will not permit vehicles with LP gas containers to pass through highway tunnels. If your route includes a tunnel, check with the highway patrol or department of highways to avoid inconvenience.
13. Do not leave food or odor-causing material in your vehicle for extensive periods of time. Always allow damp clothing, hunting gear, etc., to dry before stowing.
14. Become familiar with the fire extinguisher and make sure it is always fully charged. Remove and replace it and read instructions so you know the correct operating procedure before an emergency.
15. Make a list of all groceries, fresh meats, vegetables, newspapers, etc., that you may need and try to pick them up during your last fuel stop of the day. This will prevent leaving a good parking spot once you have arrived at your destination.
16. When you sit over the front wheels while driving, as in a motor home, you have a tendency to crowd the middle of the road. Check the side view mirror frequently to observe how close you are driving to the center line.

## SEVERE WEATHER INFORMATION

One of the more serious conditions affecting the motor home traveler and camper is that of the weather. Should you desire the high mountain terrain, the lower desert and flatland or the plain country of the midwest, the weather is always with you and subject to change, sometimes with little or no notice, but usually with adequate warnings broadcast over local radio and TV stations.

Motor home travelers and campers often seek secluded areas for weekend recreation or extended summer vacations. Many recreational areas are vulnerable to severe weather situations, especially flash flooding conditions. A few simple precautions may help lessen the hazards of flash flooding or reduce your immediate involvement.

### IMPORTANT

It is recommended that all motor home occupants become familiar with these safety precautions, and be constantly alert for any changes in the weather.

- Be alert, keep an eye to the sky because thunderstorms can form at any time in any month of the year. Thunderstorms can produce heavy amounts of rain over a small area in a short time which may result in a flash flood. Listen frequently to weather reports on radio for weather and flood conditions.
- When camping near a stream, leave plenty of sloping bank between you and the stream.
- Avoid deep canyons and dry washes during stormy or threatening weather (constantly be alert for alternate exits).
- If heavy rain occurs, move to high ground immediately (at least 30-40 feet above the canyon floor or bottom of dry wash).
- During a flash flood, if you can't move your vehicle, abandon it. Don't attempt to return to your vehicle before the water has receded.
- Don't attempt to wade to your vehicle if the water is above your knees—fast moving water exerts an enormous amount of pressure, making it impossible to remain standing or walking.
- Don't try to drive through flooded areas.

- Follow instructions of local authorities. Leave immediately when advised to do so. Many lives have been lost because people didn't heed warnings.
- Have on hand survival supplies for several days, including food, water, first aid equipment and necessary medications. In desert areas during hot weather allow 3-4 gallons of drinking water per person, per day.
- Before you leave home, inform someone of your destination and when you expect to return. Authorities at your destination should be notified immediately if you do not return on time.

### REMEMBER THESE TERMS:

**WATCH:** Severe weather may develop in the specified area. Be alert and prepare for possibility of an emergency.

**WARNING:** Severe weather is occurring, or is imminent in certain areas. Move to a safe location immediately.

It is highly recommended that the motor home operator obtain a weather radio. These radios offer up-to-date weather condition broadcasts. During good weather, the latest observations and forecasts are tape-recorded by local Weather Service offices in messages that last from three to five minutes. These messages are replayed continually 24 hours a day.

The recorded messages are revised every three to four hours, or more frequently when appropriate. When severe weather threatens, forecasters at the local Weather Service office interrupt the broadcasts with storm warnings, either recorded or "live" as the situation demands.

The frequencies used for NOAA Weather Radio (National Oceanic and Atmospheric Administration) nationwide are 162.40, 162.475 or 162.55 megahertz.

### NIGHTTIME DRIVING

- Make sure all running lights and signal lights are clean and in working order. Periodically have your headlights checked and adjusted.
- Although cars can tell when they are clear of you when they pass, longer vehicles such as motor homes have a more difficult time making judgement. Use care when passing other vehicles. Have occupants assist in observing traffic and the vehicle being passed.

### MOUNTAIN DRIVING

Special techniques must be used when driving in mountainous or hilly country. When ascending upgrades the transmission will automatically drop into a lower gear. If the grade of the incline is constantly changing and the automatic transmission is repeatedly upshifting and downshifting, select the lowest adequate gear range for the duration of the incline.

#### CAUTION

Observe the engine temperature gauge more frequently than normal. In the event an overheating condition occurs, pull off to the side of the road and allow the engine to thoroughly cool before refilling the radiator and restarting the engine.



## SECTION 5

# LP GAS SYSTEM

(See also Safety Precautions, Section 1 of this manual.)

### LP GAS SUPPLY

The LP gas system supplies fuel for the range, water heater, furnace and refrigerator (while in gas mode). When used and handled properly, this system is safe and economical and provides modern living conveniences wherever you travel.

### SAFE USE OF THE LP GAS SYSTEM

- Exercise caution at all times. Be familiar with the distinctive odor of LP gas. If a leak is suspected, turn off the supply valve immediately. Have the LP gas system checked by your dealer or a qualified LP gas service center.
- Be sure that the LP gas leak gauge is operating properly. Perform the recommended tests daily. Refer to the manufacturer's information in your Motor Home Operation Manual for further instructions.
- Do not tamper with the LP gas piping system, pressure regulator or gas appliances. Service and maintenance of LP gas system components should be performed only by your dealer or a qualified LP gas service center.
- Never attempt to connect natural gas to the LP gas system.
- Have the entire LP gas system inspected for possible leaks and missing or damaged parts at each tank filling. Also inspect before and after each trip, and any time trouble is suspected.
- Turn the LP supply valve off when not using the LP gas system.
- Never use a wrench to tighten the tank supply valve. It is designed to close leak-tight by hand. If a wrench is required to completely close the valve, it is defective and must be replaced.
- Never allow the tank to be filled above the 80 percent level indicated by the flow of liquid gas out of the overflow valve or by the automatic stop-fill device.
- Be sure appliance and outside vents are open and free from obstruction when using the LP gas system.

- Never attach a lock or any device requiring a key to the LP tank compartment door. According to standards set for recreation vehicles, the LP supply valve must be readily accessible in an emergency.
- Exercise caution when drilling holes or attaching objects to the walls. Gas lines and electrical wiring could be seriously damaged and present an extreme safety hazard.

### How LP Gas Works

LP (Liquified Petroleum) gas is a true gas compressed into liquid form for easy transportation and storage. It is known by several names such as tank gas, bottled gas or simply as butane or propane, which are the two types of LP available.

LP is used by appliances in vapor form only, but is stored in the tank as a liquid under very high pressure. As the liquid gas is released, it reverts back to a vapor and expands to many times its compressed volume. It passes through a regulator which reduces the pressure to be used by the appliances. This is how so much fuel is available from a relatively small container.

### Selecting Fuel Types

Butane burns hotter than propane, but will not develop a usable gas vapor at temperatures lower than 32° F. Propane, on the other hand, does not burn as hot but will convert to usable gas at temperatures down to -44° F. For this reason, propane is popular in cold climates, while butane and propane/butane mixtures are used most widely in milder climates.

### IMPORTANT

Most LP dealers normally handle only the type of LP gas commonly used in their climate and area. If you anticipate filling your tank in one of the warmer states prior to traveling to a colder area, it is advisable to request propane only. Otherwise your LP system may fail to operate if the temperature drops below 32° F.

Each gallon of liquid LP gas contains approximately 92,000 BTU's of heat energy; or putting it another way, each gallon of LP gas produces approximately 36.2 cubic feet of dry gas for cooking, heating, water heating and refrigeration.

To find out how long a gallon of LP gas will last, you should determine the total BTU input on all your LP gas appliances in use. Let's say you have a heater that has a 10,000 BTU input per hour of operation. A gallon of LP gas would last 9.2 hours of continuous operation ( $92,000 \div 10,000 = 9.2$ ). To estimate how long a gallon of LP gas lasts, try to determine what your total daily BTU input is, then divide into 92,000 to arrive at an approximate daily LP gas consumption.

## WARNING

Test the LP system with the leak detector each time the gas valve at the tank is turned on. Never attempt to connect natural gas to the LP gas system.

### BULK TANK SYSTEM

The storage reservoir for the LP gas system is a horizontally mounted tank which is permanently attached to the vehicle frame. The tank is accessible only from the outside of the vehicle. The tank control valve is located near the top center of the tank, next to the regulator. Before opening the control valve, check to be sure all controls for gas appliances are in the "Off" or "Pilot Off" position. If this step is not performed, LP gas could accumulate inside the motor home creating a fire or explosion hazard.

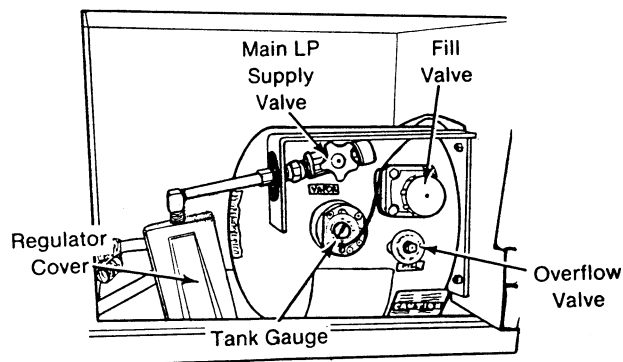

Typical LP Gas System Controls

### Refilling Bulk LP Tank

There are many LP gas refueling stations located throughout the country. These stations are listed in the telephone directory in the Yellow Pages under "Gas—Liquified Petroleum—Bottled and Bulk."

Since the bulk LP container is permanently mounted to the frame, the motor home must be taken to an LP dealership for filling. Do not attempt to remove the LP tank from the vehicle. The bulk tank is equipped with a fill adapter with both internal and external threads which allows easy filling with any LP filling equipment. The tank is full when liquid LP gas appears at the overflow valve.

NOTE: The LP tank is equipped with an automatic 80% stop-fill device.

### Air in the LP Gas Tank

Air in LP gas containers must be removed prior to initial filling with LP gas. If the container is not properly purged, air in the container dilutes the LP gas vapor. Appliances then require constant adjustment and pilot lights won't stay lit. This condition could exist for several months until all air is depleted, leaving pure LP gas vapor. Your LP gas dealer is equipped to purge the tank of air prior to filling.

### TRAVEL WITH LP GAS

It is illegal for vehicles equipped with LP tanks to travel on certain roadways or through certain tunnels in the U.S. To avoid inconvenience, check state regulations concerning flammable gas transportation.

## WARNING

Do not alter or remove LP tank gauge at any time.

## WARNING

DO NOT FILL CONTAINER TO MORE THAN 80 PERCENT OF CAPACITY. Make sure the motor home is level when filling. It is possible to accidentally overfill the tank if the vehicle is unlevel, especially if the fill valve is on the uphill side. Overfilling the LP gas container can result in uncontrolled gas flow which can cause fire or explosion. A properly filled container will contain approximately 80 percent of its volume as liquid LP gas.

All pilot lights **must be extinguished** and supply valve closed before refilling LP gas tanks or vehicle fuel tanks.

Because of the extreme flammability of LP gas and its heavier-than-air qualities, **do not** smoke or expose the tank to an open flame while near a refueling area. **Never** use an open flame to test for gas leaks.

Replace all protective covers and caps on LP system after filling.

**Never** fill the LP tank with engine or generator running.

## REGULATOR

The pressure regulator is protected from the elements by a plastic cover which should be left in place at all times. Any removal of the cover and adjustments of the regulator should be done by your dealer or a qualified LP gas dealership.

## WARNING

Inspect the pressure regulator vent hole periodically for blockage. If any obstruction is apparent, have the regulator serviced by your dealer or a qualified LP gas service center.

LP gas regulators are installed with the diaphragm vent facing downward. Make sure that the regulator vent always faces downward to minimize vent obstruction which could result in excessive pressure, causing a fire or explosion.

Regulator freeze-ups are caused by the presence of moisture in fuel. This moisture will pass through the cylinder valve and into the regulator where it freezes. Fuel producers, tank and bottle manufacturers and LP gas dealers take every precaution to reduce moisture, but sometimes only a fraction of an ounce entering the tank can cause problems. To help avoid the possibility of freeze-up, always keep tank control valve closed when not in use, even when tank is empty, to prevent moisture from collecting on the inside.

If in spite of every precaution, regulator freeze-up should occur, you may attempt to thaw the regulator using a small light bulb. **DO NOT USE AN OPEN FLAME OR HEAT LAMP.**

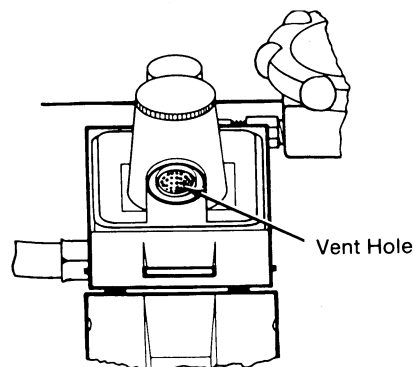

LPG PRESSURE REGULATOR  
(Cover Open)

If moisture begins causing problems, have your LP gas dealer inject a small amount of dry methyl alcohol in your tank (approximately one ounce to 20 pounds or one pint to 100 gallons) to help guard against regulator freeze-ups.

In very cold weather when a large volume of gas is being used for heat production, it is possible to experience a loss of gas pressure. At first occurrence this problem may appear to be caused by a regulator freeze-up, but is actually caused by failure of the liquid gas to vaporize as fast as it is needed. As the temperature becomes colder, it is increasingly harder for the liquid LP gas to "boil-off" into a vapor. At the same time, the demand for LP to produce heat increases to the point where the system cannot maintain production. The only actual solution to this problem is to reduce the consumption of gas where possible. Adjusting the temperature on the gas/electric refrigerator may be a first step. Using less hot water will help as well.

## LP GAS LEAKS

The following label has been placed in the vehicle near the range area. If you smell gas within the vehicle, quickly and carefully perform the procedures listed.

### IF YOU SMELL GAS

1. Extinguish any open flames, pilot lights and all smoking materials.
2. Do not touch electrical switches.
3. Shut off the gas supply at the tank valve(s) or gas supply connection.
4. Open doors and other ventilating openings.
5. Leave the area until odor clears.
6. Have the gas system checked and leakage source corrected before using again.

## LP Leak Gauge

Your coach is equipped with a pressure-drop indicator gauge (manometer) to test for LP gas line leaks. This gauge is located in the refrigerator access compartment on the exterior of the coach and is easily accessible when required. A leak test should be performed before using the LP system in the following situations:

- after storage periods.
- each time after opening the main supply valve.
- after each LP tank fill.
- daily during periods of extended use.

Read the following operating instructions and additional information in your Owner Operation Manual before conducting the LP gas leak test.

### IMPORTANT

This device does not prevent leaks. It detects and indicates leakage only while operated and observed.

If the gauge indicates a leak, recheck to be sure all appliance gas valves have been shut off.

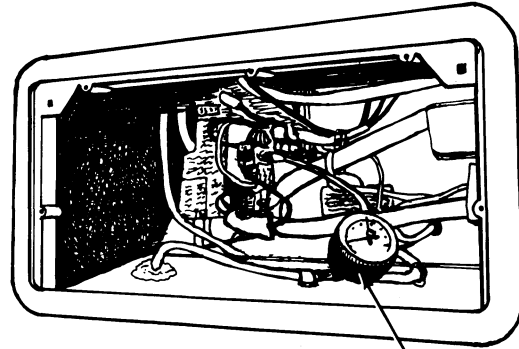

Leak Gauge

(Located in Refrigerator Compartment)

## WARNING

Do not smoke or expose the unit to open flame or extreme heat when conducting an LP gas leak test. Never use an open flame to test for gas leaks.

### Instructions:

1. Close LP gas tank or cylinder valve(s).
2. Ventilate vehicle. Open doors and windows.
3. Shut off LP gas appliances, including pilots.
4. Now, slowly open LP gas tank or cylinder valve(s).
5. Observe the pressure reading on the gauge as indicated by the black pointer (A) and match this position with the moveable red pointer (B).

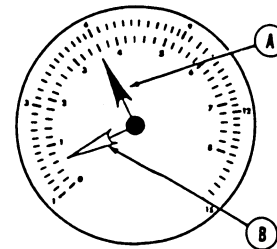

6. Close LP gas tank or cylinder valve(s).
7. With LP gas tank or cylinder valve(s) in a closed position, monitor position of the black pointer for a period of 5 minutes.
  - A. If the black pointer does not move to a lower setting on the gauge, as compared to the red pointer, your system is secure at this time.

- B. If the black pointer does move to a lower setting on the gauges, as compared to the red pointer, the system has a leak.
- 8. Conduct a soapy water test at all joints. Tighten if necessary and retest.

**WARNING**

Never use an open flame to test for gas leaks.

Check for leaks with the leak gauge each time the gas valve at the tank is opened and each day during periods of prolonged use. When testing for gas line leaks with a soapy water solution, DO NOT use a detergent containing ammonia or chlorine. These substances may generate a chemical reaction causing corrosion to gas lines resulting in dangerous leak conditions.

- 9. If test still shows a leak, contact your Winnebago/Itasca dealer.

**WINTER USE OF LP GAS**

Due to vaporization characteristics of LP gas, it is important that the winter camper knows how to most efficiently use the LP system. The vaporization rate of LP gas decreases in a direct relationship to a decrease in temperature. As explained in the "Selecting Fuel Types" section, butane does not vaporize below 32° F, so propane must always be used in cold climates. However, even propane vaporizes at a slower rate as it becomes colder.

The greater the amount of liquid gas in the tank (up to the 80% level) the greater the amount of LP gas vapor generated. The following is an example of the number of BTU's available from an 84-pound tank at 0° F at three levels. As you can see, the number of BTU's decreases as the tank is emptied. Nearly twice as many BTU's are available from a full tank than one that is one-fourth full.

BTU's Available at 0° F.

Tank Level	BTU's
80%	64,400
50%	50,400
20%	33,000

The following LP Gas Vaporization and Temperature Relationship chart typifies the LP gas loss with a decrease in temperature. The percentage figures are the increase or decrease of vapor that would be available at 0° F. These figures are applicable to all size LP gas tanks.

Temperature	Percentage of BTU's Available at 0° F.
20° F.	200%
10° F.	150%
-5° F.	75%
-10° F.	50%
-15° F.	25%
-20° F.	12½%
-44° F.	Propane will not vaporize

**WARNING**

Make sure the filling attendant uses the 80% overflow valve when filling the tank. A tank should never be filled above the 80% level to allow for vaporization and liquid expansion.

Do not place LP gas containers inside the vehicle. LP gas containers are equipped with safety devices which relieve excessive pressure by discharging gas to the atmosphere.

Do not place LP gas containers, gasoline, or other flammable liquids inside the vehicle. Fire or explosion may result.

037 8 1 1000

## SECTION 6 ELECTRICAL SYSTEMS

(See also Safety Precautions, Section 1 of this manual.)

All Winnebago and Itasca motor homes are equipped with an electrical system consisting of two separate voltages: a 12-volt DC system and a 110-volt AC system. The 12-volt system consists of two internal power sources, while the 110-volt system is operated from an outside power source or the optional 110-volt generator. All systems operate through a single power converter control center to provide electrical power to the motor home.

### 110-VOLT AC SYSTEM

The 110-volt system operates from an outside 110-volt utility service such as those at campgrounds, or from the optional 110-volt generator on units so equipped. When the power cord is connected to an outside power source, or when the generator is in operation, the power converter automatically changes a portion of the 110-volt current to 12-volt DC current. All equipment in the motor home that is normally powered by the auxiliary battery is then powered through the converter.

In addition, the following equipment is entirely dependent on the 110-volt generator or outside source: roof air conditioner, refrigerator (when placed in 110-volt mode), microwave oven, ice maker, vacuum cleaner and other 110-volt electrical equipment used at convenience outlets.

### External Power Cord (Shoreline)

The external utility power cord (commonly referred to as a "shoreline") is stored in a compartment located on the left side of the motor home. (On Chieftain or Sunflyer models, it is located in the "trunk" compartment.)

## WARNING

**Do not** connect the external power cord to any receptacle **until** you have contacted the owner and/or attendant of the premises to verify proper polarity and grounding.

It is the responsibility of the owner of the electrical receptacle to ensure that the receptacle is properly wired and grounded.

Reverse polarity and improper grounding of the vehicle can cause personal injury or death.

To connect to an external power source, remove the cord from the storage compartment and plug it into a suitable power receptacle.

A small "hatch" provided in the compartment door allows the door to be closed while the cord is attached to an external source.

30 Amp Receptacle

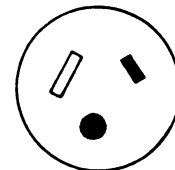

The three-wire power cord is designed to ground the electrical system through the receptacle. It is also designed to carry the amperage output of most campground outlets. If the electrical receptacle to be used is designed to mate with the three prongs on the power cord plug, the electrical connection can be expected to carry rated load.

Should an overload on an appliance occur due to an excessive amperage draw, the breaker for the appliance, located on the power converter panel, will trip.

## WARNING

**Do not** plug the power cord into an outlet which is not grounded, or adapt the plug to connect to a receptacle for which it is not designed.

Be sure that all three prongs of the supply cord are properly plugged into the receptacle.

**Do not** connect the power cord to an extension cord.

**Do not** plug the power cord into the generator receptacle while the generator is running.

Most campgrounds are equipped with a fuse or circuit breaker at the receptacle. This protects the park's wiring, as well as the power cord on your vehicle, from electrical damage. If electrical power fails, contact the park attendants and have them check the fuse or breaker for your supply receptacle.

When disconnecting the power cord, neatly replace it in the storage compartment.

### Power Control Center (Converter)

The power converter changes 110-volt AC current from the auxiliary generator or the shoreline into 12-volt DC current for use by 12-volt equipment in the motor home.

Certain circuits, however, remain unchanged for use by items which require 110-volt current, such as the air conditioner(s), the refrigerator in AC mode, the microwave oven, etc.

Current drawn from the coach batteries passes through the power center unchanged, although it is routed through a series of protective fuses located on the power panel.

The converter is located in a lower cabinet face in the galley, living area or beneath a bed. The converter power panel contains the coach electrical system 110-volt circuit breakers and 12-volt fuses.

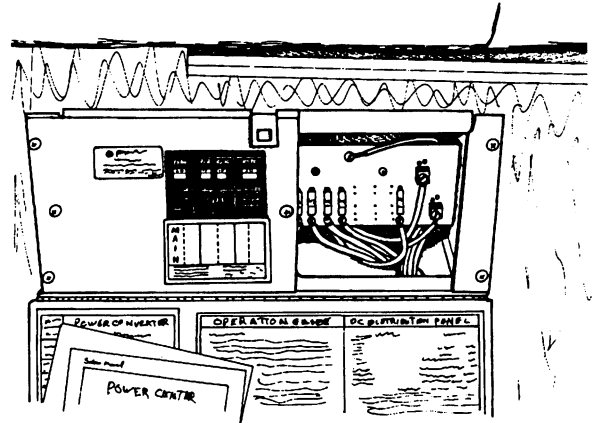

Power Converter

## WARNING

Do not store anything on or around the power converter, as it requires unrestricted air flow to dissipate generated heat.

### Power Converter and Circuit Breaker Locations (Chieftain and Sunflyer)

Chieftains and Sunflyers are not equipped with the combination converter/power center shown in the illustration. These models are equipped with a converter system made up of individual components located in various parts of the coach.

- Converter Unit: beneath driver compartment floor riser.
- 12-Volt Circuit Breaker Panel: behind cabinet door above refrigerator; contains pop-out breakers.
- 110-Volt Breaker Panel: beneath twin bed or in lower face of nightstand cabinet on driver side or in a rear overhead cabinet above the bed.

### Power Converter and Circuit Breaker Locations (Superchief DX/L and Suncruiser DX/L)

Superchief and Suncruiser DX/Ls are not equipped with the combination converter/power center shown in the illustration. These models are equipped with a converter system made up of individual components located in various parts of the coach.

- Converter Unit: in the basement compartment behind the drive axle.
- 110-Volt Circuit Breaker Panel: in cabinet in bedroom closet.

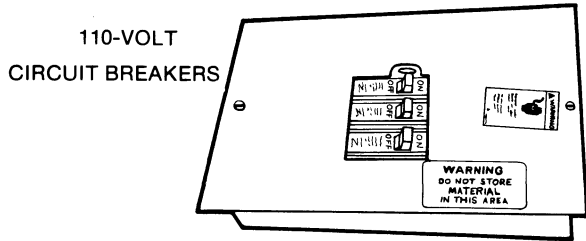

- 12-Volt Circuit Breaker Panel: in left side of cabinet above toilet.

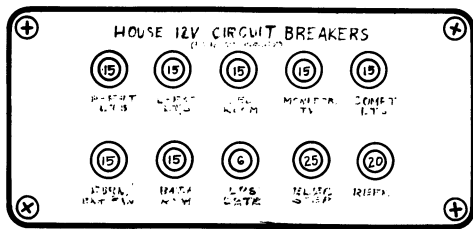

12V Circuit Breaker Panel

### Charging Section

The converter charges coach batteries while 110-volt external power is connected. The converter will automatically “sense” the condition of the RV battery. If it is below “full charge,” the Charging Section will start charging the battery.

If the coach batteries have been extremely discharged, they will accept charge at a relatively high amperage rate. If they are only slightly discharged, they will charge at a lower amperage rate. The rate of charge will decrease as the batteries reach “full charge.” Active charging will not resume until batteries again fall below “full charge.” The converter will not overcharge the batteries. If your storage battery does not charge as described above, it is possible the battery is defective.

### Thermal Breaker

A protective thermal breaker will “break” the 110-volt AC power to the converter section of Power Center if the power converter becomes overheated from operating above its maximum limit for an extended period of time or by obstruction of ventilation to unit.

NOTE: Power converter section will automatically route 12-volt lights and motors to battery power in this event.

The thermal breaker will reset itself after a period of time, and the lights and motors will again resume operation from power converter section. If the breaker trips again shortly after reset, take immediate steps to correct cause of overheating. A portion of RV 12-volt load (lights or motors or both) should be turned off to reduce total load. Also, inspect power converter section to make certain ventilation is not obstructed.

### IMPORTANT

The converter will not change 12-volt DC current to 110-volt AC.

### 110-Volt Circuit Breakers

The breaker panel protects all 110-volt components in the motor home from either an overload on the circuit or a short in the wiring or component itself. When an overload or short develops, the breaker will open preventing any further flow of electricity and, therefore, damage to the system.

Shut off the equipment (example: roof air conditioner) and allow a brief cooling period. Then reset the breaker by moving the switch to “Off” and back to “On.” If the breaker is continually tripped and no overload is evident, have the system checked for a short in the wiring or the appliances.

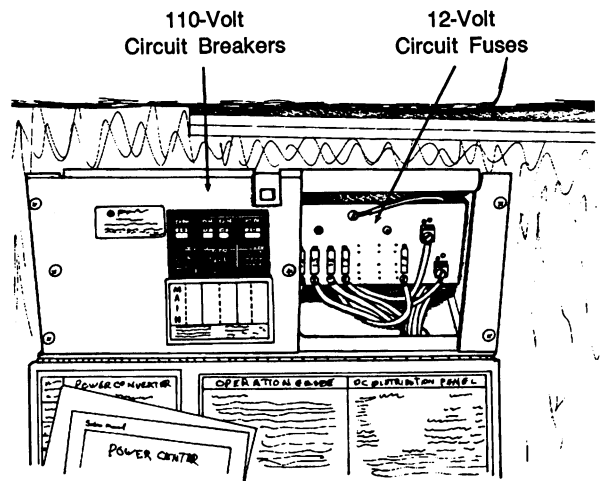

### 110-Volt Receptacles (Outlets)

A number of standard AC electrical outlets are provided throughout the coach for connecting small appliances such as televisions, radios, toasters, etc. Exterior outlets are also located on the outside of the coach near the entrance door, or in an exterior compartment.



## GROUND FAULT CIRCUIT INTERRUPTER

Exterior, bath and galley outlets are connected to a GFCI (Ground Fault Circuit Interrupter), which is an extremely sensitive circuit breaker that will help to protect against severe electrical shock if a ground fault develops. If such a condition occurs, the GFCI will break the circuit by turning off the power to the protected outlet. Should this occur, unplug all the appliances on that circuit and press the reset button on the GFCI equipped outlet.

If the GFCI keeps tripping, have the electrical system checked and repaired if necessary before using again.

The GFCI outlet is located in the bath, bedroom or dinette area, depending on the floor plan of the vehicle.

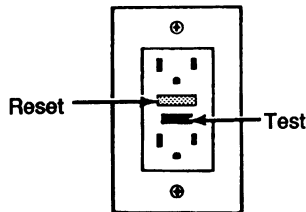

## WARNING

The GFCI will not completely eliminate electrical shock. Small children and persons with heart conditions or other disabilities which make them especially sensitive to electrical shock may still be injured by 110-volt receptacles even though protected by a Ground Fault interrupter.

**NOTE:** The galley outlet in Canadian equipped units is not GFCI protected. The GFCI breaker in Canadian vehicles is located on the breaker panel in the Power Control Center (converter).

## AUXILIARY 110-VOLT GENERATOR (Optional)

Consult the information provided in your Owner Operation Manual binder for instructions on operation, troubleshooting and maintenance.

## WARNING

**Careless handling** of the generator and electrical components can be fatal.

**Never** touch electrical leads or appliances when your hands are wet, when standing in water or on wet ground.

**Do not** attempt to repair the generator yourself. Service should be performed by an authorized service center.

**Do not** plug the power cord into the generator receptacle while the generator is running.

To use the 110-volt generator, plug the power cord into the generator receptacle within the shoreline compartment.

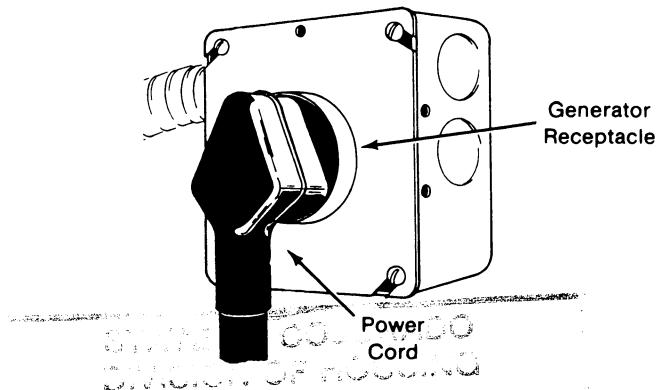

### Starting the Generator

1. Turn the Auxiliary Battery Disconnect Switch on (if equipped) to connect power to the generator starter motor.
2. Press the generator switch into the ON position and hold until the engine is running and the green ON indicator is lit. The switch must be held in position for several seconds after the generator has started to allow the generator to reach full operating voltage. The generator ON indicator will remain lit while the generator is in use.

## CAUTION

Damage to the automotive alternator can occur if the 110-volt auxiliary generator is started while both batteries are connected.

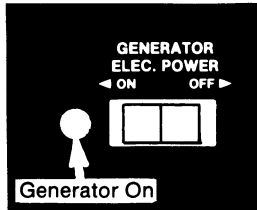

3. Allow the generator to stabilize by running 3 to 5 minutes before turning on appliances.
4. Apply electrical loads. Refer to *SPECIFICATIONS* section of generator manual for generator set output and performance ratings. Then refer to the chart below to aid in determining appliance usage during generator operation.

## CAUTION

Continuous generator overloading can cause high operating temperatures that can damage the generator windings. Keep the electrical loads within the generator wattage rating.

### APPROXIMATE POWER REQUIREMENTS OF COMMON APPLIANCES

Appliance or Tool	Approximate Running Wattage
Refrigerator	600-1000
Electric broom	200-500
Coffee percolator	550-700
Electric frying pan	1000-1350
Hair dryer	800-1500
Electric stove (per element)	350-1000
Electric iron	500-1200
Radio	50-200
Electric water heater	1000-1500
Space heater	1000-1500
Electric blanket	50-200
Television	200-600
Electric drill	250-750
Battery charger	Up to 800
Air conditioner	1400-2000
Converter	300-500
Microwave oven	700-1500

### Stopping the Generator

1. Shut off electrical equipment to remove load. Allow generator to run for 3 to 5 minutes to cool down.

2. Press the generator switch into the OFF position and hold until the generator comes to a complete halt.

### Generator Hourmeter (If Equipped)

This meter registers the total number of hours that the generator has been operated. Refer to the hourmeter often to determine when periodic maintenance is due and to record services which have been performed.

### Operation Warnings and Cautions

## WARNING

The exhaust of all internal combustion engines contains carbon monoxide (CO). This gas is colorless, odorless, tasteless, lighter than air and poisonous. The exhaust systems of both your motor home engine and your generator engine have been installed with your safety in mind. However, certain precautions must be taken in their use to protect you from conditions beyond the control of the manufacturer.

1. **Do not** simultaneously operate the generator engine and a ventilator which could draw air into the vehicle, resulting in the entry of exhaust gases.
2. **Do not** open windows or ventilators on the end or side of the vehicle where exhaust of the generator is located.
3. **When parked**, orient the vehicle so that the wind will carry the exhaust away from the vehicle. Also, note the position of other vehicles.
4. **Do not** operate the generator engine when parked so that vegetation, snow, buildings, vehicles, or any other object can deflect the exhaust under or into the vehicle.

### 12-VOLT DC SYSTEM

The DC voltage system consists of the automotive battery and the 12-volt motor home auxiliary batteries. The automotive battery is used solely to operate the engine starter and all automotive accessories and controls found on the instrument panel. This includes the horn, speed

control, all exterior lights, radio, windshield wipers, rear auto heater fan, etc.

The auxiliary batteries supply current to all 12-volt equipment located in the living area of the motor home. This includes: interior lights, range exhaust fan, furnace fan, water pump, water level and holding tank gauges, 110-volt generator starting, refrigerator, bath roof vent fan, and the rear automotive heater. In addition, the auxiliary battery may be used to start the engine if for some reason the automotive battery is discharged; refer to "Battery Mode Switch."

### 12-Volt Fuses and Circuit Breakers

All 12-volt circuits and equipment in the coach area of the motor home are protected by a fuse panel or breaker panel. When a circuit is overloaded or a short develops in any part of the system, a fuse or breaker will shut down that circuit. If this happens, turn off all affected lights or appliances and reset the breaker or replace the fuse with a new one of equal amperage rating.

A label on the panel states the amperage rating and circuit protected for each fuse or breaker.

### Fuse Panel

The fuse panel is mounted on the right-hand side of the power converter.

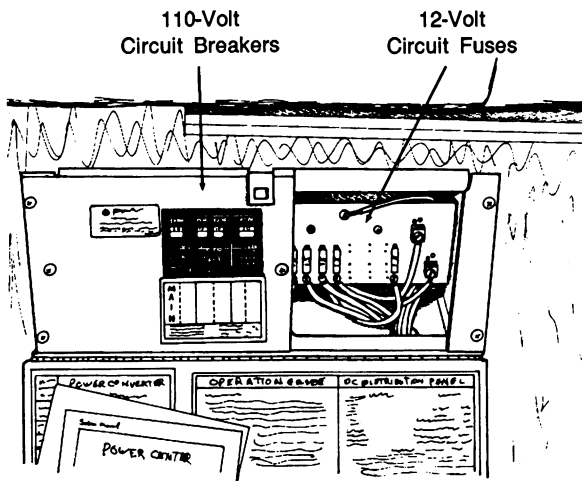

The fuse panel accepts only blade type plug-in fuses. Always replace fuses with those of the same amperage rating.

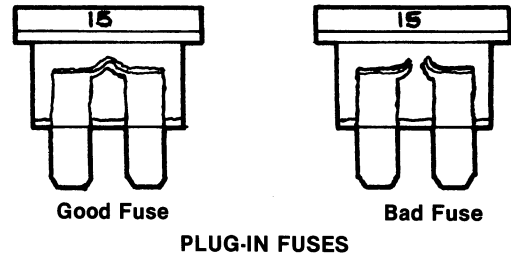

NOTE: Chieftain and Sunflyer models are equipped with pop-out circuit breakers. The breaker panel is located behind the cabinet door above the refrigerator.

## BATTERY INFORMATION

### AUTOMOTIVE BATTERY ACCESS

The automotive batteries for all models are located in the engine compartment.

### AUXILIARY (COACH) BATTERY ACCESS Elandan & Windcruiser Models (With Cab Doors)

The auxiliary batteries are located in separate compartments in the pilot and co-pilot door stepwells. Remove the four screws that retain the stepwell panel, slide the panel up and remove. Next, extract the screws fastening the metal cover to the stepwell and remove the cover. To slide the battery tray out for servicing, pull up on the tray retainer pin and pull tray outward.

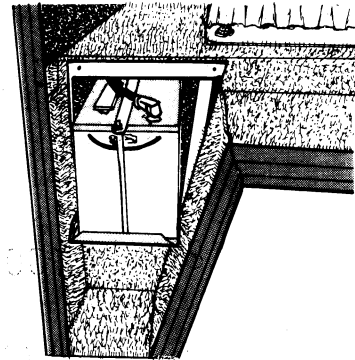

### (Without Cab Doors)

If your vehicle is not equipped with a passenger cab door, the auxiliary battery compartment on that side of the vehicle is located below the floor directly behind the passenger seat. Remove the access cover on the floor behind the seat to inspect or service the battery. (This also applies to the driver side of the vehicle if not equipped with a driver cab door.)

**Superchief & Suncruiser Models  
Warrior & Spirit (A-Bodies only)**

These models contain an auxiliary battery compartment accessible from the interior of the coach. To gain access, unfasten the latch at the front of the top entrance step and open the carpeted compartment door upward.

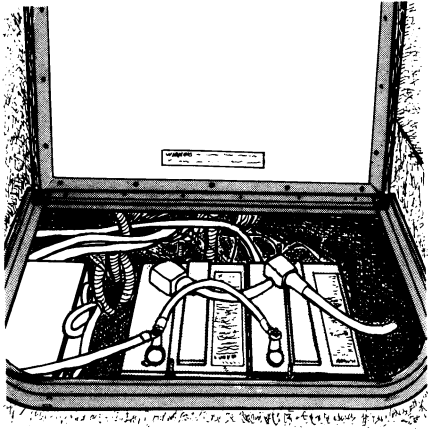

To service or remove the batteries, pull the retainer pin from the tray and slide the tray outward.

(The auxiliary battery for model W/IF427RT is located in the engine compartment.)

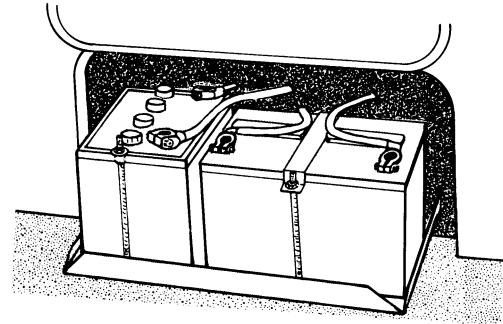

**WARNING**

Reinstall the retainer pin when returning the tray to the storage position.

**Chieftain & Sunflyer Models**

The coach batteries are located behind an exterior access door to the rear of the front tire on either the driver or passenger side, depending on model.

(The opposite compartment is intended for storage.)

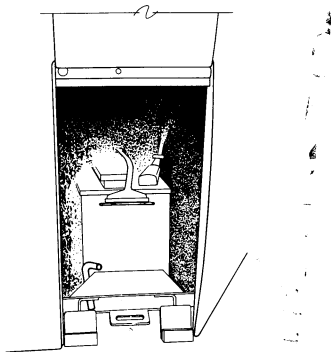

To service or remove the batteries, pull the retainer pin from the tray and slide the tray outward.

**All C-Body Models (Except 427RT)**

The auxiliary batteries are located in an exterior battery storage compartment. They are mounted in a slide-out tray for convenient access for periodic inspection or maintenance.

**Battery Maintenance**

A battery is merely a storage reservoir, not a source of electricity. As soon as energy is removed from the battery, it should be replaced by the alternator system. If a battery is left in a discharged state without being recharged for long periods of time (30 to 90 days), it will sulfate and lose charging capacity. To ensure that the battery will always accept and hold a charge, some minor maintenance practices should be followed.

Make sure that batteries always remain securely clamped in the battery tray and the cable clamps are tight on the terminal posts and free of corrosion. Any corrosion buildup on the battery may be neutralized by washing with a solution of baking soda and water and then rinsing with clear water.

**IMPORTANT**

Make sure vent caps are on securely to prevent baking soda solution from contaminating the battery electrolyte.

## WARNING

Before removing any battery cables or battery, make sure all 12-volt equipment in the motor home is off and the power cord has been disconnected.

Be sure to replace the battery terminal boot back onto the positive terminal before sliding tray in after servicing. Care must be taken when sliding the battery tray back in, to avoid pinching the extra cable between the tray and the vehicle frame. Should the cable be damaged, a short could result in personal injury or damage to equipment. Replace any damaged cables at once. Always remove jewelry and wear protective clothing and eye covering when checking or handling batteries.

Reinstall the retainer pin when returning the tray to the storage position.

Clean and tighten battery terminals and have the specific gravity checked at least once a year. Every two months, or more often in hot weather, check the battery fluid level. Fill to approximately 3/8 inch above the plates. **DO NOT OVERFILL.** If fluid is added during freezing weather, the motor home should be driven several miles to mix water and electrolyte and prevent freezing. Fluid level check may be omitted if equipped with maintenance-free batteries.

## WARNING

To prevent wiring damage, it is essential when replacing the cables on the battery, or when using a "booster" battery, that the positive post and the positive cable be attached and the negative post and negative cable be attached. The posts are marked (+) plus and (-) minus. If a "fast charger" is used while battery is in the motor home, disconnect both battery cables before connecting the charger. Never attempt to charge or boost a frozen battery.

## BATTERY CONDITION METER AND SWITCH (Optional)

This gauge allows the driver to monitor the state of charge of batteries in the motor home. The battery condition switch is used to select the battery to be monitored. Depress the left side to monitor the automotive battery; the right side to monitor the auxiliary battery.

To obtain an accurate reading:

1. The battery modes switch must be in the neutral position.
2. Both the automotive engine and the auxiliary generator must be stopped.
3. An interior light should be turned on to provide a small load which draws off battery surface charge.

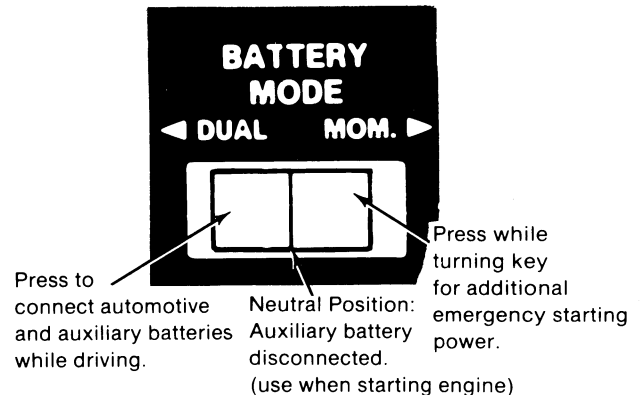

## BATTERY MODE SWITCH (Not Available in Diesel Equipped Vehicles or Model 319RB)

The battery mode switch is used to connect the auxiliary batteries to the automotive electrical system, allowing them to be recharged by the engine alternator while driving. The momentary (MOM) position can be used to provide additional starting power from the motor home auxiliary battery if the automotive battery is discharged.

## CAUTION

Damage to the automotive alternator can occur if the 110-volt auxiliary generator is started while both batteries are connected.

### **AUXILIARY BATTERY DISCONNECT SWITCH (If Equipped)**

This switch allows you to conveniently disconnect the auxiliary battery during prolonged storage periods without the need for removing a battery cable in the battery compartment. This disconnection reduces the possibility of battery drain by electrical devices (such as clocks) which are energized continuously.

The auxiliary battery switch is intended to be used to disconnect the auxiliary batteries during extended periods of non-use or for seasonal storage. It should not be used in an attempt to "save" the auxiliary batteries while using the 110-volt system.

Press the switch momentarily to the ON position to connect the coach batteries. Press momentarily to the OFF position to disconnect. The switch is spring-loaded and will return to the neutral position when released.

#### **Testing the Auxiliary Battery Disconnect Switch:**

1. Turn off the generator.
2. Disconnect the shoreline.
3. Turn the ignition to the OFF position.
4. Put the Dual Momentary Switch in the OFF position.
5. Press the Auxiliary Battery Disconnect Switch to the ON position.
6. Turn on an overhead light. If the light works, the Auxiliary Battery is connected.

NOTE: If the overhead light does not work, the Auxiliary Battery needs charging. Read the following section for instructions.

### **CAUTION**

NEVER disconnect the auxiliary batteries while the utility power cord ("shoreline") is plugged into either the generator or an external receptacle. Electronically sensitive equipment, such as TV's and VCR's or high-amperage equipment, such as the refrigerator and electric step, may be damaged if operated while auxiliary batteries are disconnected.

### **IF THE AUXILIARY BATTERIES BECOME DRAINED**

Since the auxiliary battery switch is powered by the auxiliary batteries, the switch cannot be turned on if auxiliary battery voltage is less than 7.5 volts. It is possible to "jump start" the switch using the main battery to operate the switch and reconnect the auxiliary batteries. Described below is the procedure you should follow in this event.

1. Turn ignition key on.
2. Place the Battery Mode Switch in the Neutral (middle) position.
3. Depress **and hold** the Battery Condition Switch in the MAIN position.
4. Press the Auxiliary Battery Switch to the ON position and release.
5. Release the Battery Condition Switch from the MAIN position and press to the AUX position to verify connection of the auxiliary batteries.
6. Start the engine to provide alternator charging.
7. Place the Battery Mode Switch in the DUAL position to charge auxiliary batteries.

NOTE: This procedure is necessary only if the auxiliary batteries are extremely discharged. If the auxiliary batteries fail to reconnect, check the 5A fuses on the top of the relay and replace with 5A fuses if necessary. If the fuses are okay, another problem may exist. See your dealer for assistance.

### **BATTERY ISOLATOR (Diesel Equipped Vehicles)**

The battery isolator is designed to connect the auxiliary battery to the automotive electrical system, allowing it to be charged by the engine alternator while driving. The isolator also prevents coach equipment from drawing power from the automotive (starting) batteries.

## SECTION 7 PLUMBING SYSTEMS

### FRESH WATER SYSTEM

The fresh water system provides water to the galley sink, shower, bathroom lavatory, toilet and water heater. Water may be supplied by either of two sources:

- a water tank located within the motor home, or
- any external water source to which the motor home may be connected, known as “city water.”

### FRESH WATER TANK FILLING PROCEDURES:

#### All Models Except Chieftain and Sunflyer

The tank may be filled by inserting a hose into the tank fill opening. A built-in vent prevents the tank from becoming air-locked while filling.

When neither city water nor a hydrant are available, a bucket and funnel may be used, although this can take a considerable amount of time.

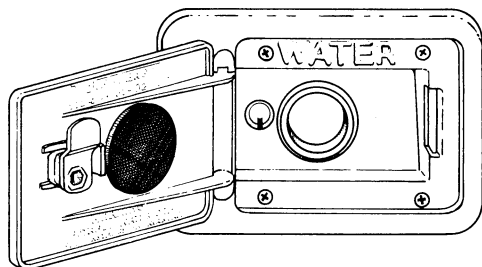

Water Tank Fill

#### Chieftain & Sunflyer Models

Your coach is equipped with a convenient Water System Compartment. This compartment combines the tank fill and city water hook-up in a single location. To accomplish this, these models were designed with a pressure-fillable water tank. This means that water line pressure is used to force water into the tank. This unique type of system requires a different technique for filling and adding solutions to the tank than other RV water systems.

#### Filling the Tank

1. Be sure the water pump switch (inside the coach) is OFF.
2. Be sure all faucets are CLOSED.
3. Attach a water hose to the city water connector.

4. Turn the outside water supply ON.
5. Turn the tank fill valve ON. The tank is full when water runs out of the overflow tube beneath the vehicle.
6. Turn the tank fill valve OFF.
7. Turn the outside water supply OFF. Then disconnect the hose.

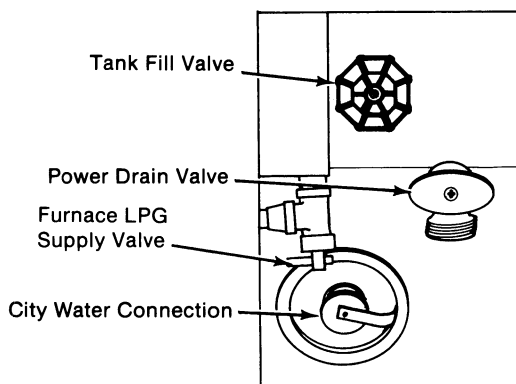

Chieftain & Sunflyer  
Water System Compartment

**NOTE:** Always keep the tank fill valve closed unless you are filling the tank. If this valve is open while using city water, the water will continuously flow into the tank and out the overflow tube.

#### Draining the Tank

The quickest and easiest way to drain the tank is to use the power drain, located in the water system compartment. To do this, turn the coach water pump ON and open the power drain valve.

When draining the entire water system for winter storage, open the water heater drain and water system drain valves along with the power drain. This allows complete drainage of all water lines as well as the tank.

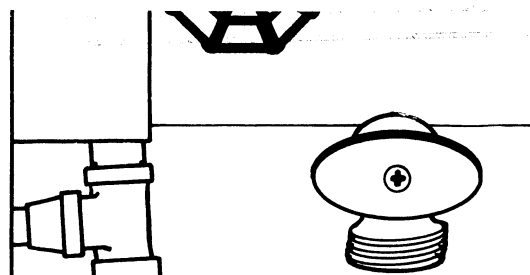

## Seasonal Storing and Sanitizing the Tank (Adding Nontoxic RV Antifreeze or Chlorine Solutions)

### WARNING

Chlorine is poisonous—recap bottle and clean utensils after use.

Never use automotive type antifreeze in your fresh water system as it is poisonous.

We recommend using a small pump that attaches to a common garden hose to force nontoxic RV Antifreeze and sanitizing solutions into the tank. These pumps are available as inexpensive hand-powered or drill-powered units and may be obtained at hardware or garden supply stores.

If a pump is not available, an alternate procedure is to attach a length of hose to the city water connector on the coach. Then fill the hose with the required solution. Next, connect the hose to an external water supply. Turn the water on and let the water pressure force the solution into the tank. Repeat as many times as needed to add the recommended amount of the required solution.

When sanitizing the water tank, follow the complete disinfection instructions as listed on page 7-3 of your operator's manual.

### Water Pump

Pressure for the water system is supplied by a water system demand pump which is fully automatic after initial priming. When a faucet is opened, the pump instantly begins operation to provide a constant flow from the tank. As soon as the faucet is closed, the pump automatically shuts off.

### Water Pump Switch

The water pump switch is located on the optional water/holding tank monitor panel. If your vehicle is not equipped with the monitor panel, the switch will be located on a lower cabinet, the panel below a bed or on the wardrobe wall panel, depending upon model. While the switch is in the "On" position, the pump will automatically supply water pressure as it is needed. It is

recommended that the pump switch be turned off whenever you are away from the vehicle or not using the water system. A slow leak in a faucet could drain the water system, and discharge the coach battery.

### Initial Start-up

1. Make sure that all water drain valves are closed, including water heater. (Refer to Section 11.)
2. Turn water pump switch to "Off" position. Fill water tank.
3. Open all faucets, hot and cold.
4. Turn on pump switch.
5. Close each faucet as it begins to deliver a steady stream of water (close cold water first). Leave hot water faucets on until they also deliver a steady stream of water. This will ensure that the water heater is filled with water.
6. Check to be sure pump stops soon after all faucets have been closed.
7. Pump is now ready for automatic operation. Pump will start when a faucet is opened and stop when the faucet is closed.

### NOTICE TO OWNERS of Chieftain, Sunflyer, Superchief & Suncruiser Models: Insulated Water Systems

Although the fresh water system is installed primarily below the floor of the vehicle, the tank and water lines are insulated to provide cold weather protection. A furnace duct routed to the water tank compartment supplements this thermal protection, allowing operation at temperatures to below 32° F. Operation at subfreezing temperatures is dependent upon individual weather conditions and duration of exposure to those conditions.

### INSTRUCTIONS FOR DISINFECTION OF FRESH WATER SYSTEMS ON RECREATION VEHICLES

(As approved by the U.S. Public Health Service)

To assure complete disinfection of your fresh water system, it is recommended that the following procedures be followed on a new system, one that has not been used for a period of time, or one that may have become contaminated. This procedure is also recommended before long periods of storage such as over winter.



1. Prepare a chlorine solution using 1 gallon of water and 1/4 cup of household bleach (sodium hypochlorite solution). With tank empty, pour chlorine solution into the tank. Use 1 gallon solution for each 15 gallons of tank capacity. This procedure will result in a residual chlorine concentration of 50 ppm in the water system. If a 100 ppm concentration is required as discussed in item 3, use 1/2 cup of household bleach with 1 gallon of water to prepare the chlorine solution. One gallon of the solution should be used for each 15 gallons of tank capacity.

2. Complete filling of tank with fresh water. Open each faucet and run the water until a distinct odor of chlorine can be detected in the water discharged. Do not forget the hot water taps.

3. Allow the system to stand at least 4 hours when disinfecting with 50 ppm residual chlorine. If a shorter time period is desired, then a 100 ppm chlorine concentration should be permitted to stand in the system for at least 1 hour.

4. Drain and flush with fresh water.

**WARNING**

Chlorine is poisonous—recap bottle and clean utensils after use.

Never use automotive type antifreeze in your potable water system as it is poisonous.

**EXTERNAL WATER SUPPLY (“City Water”)**

**To operate from an external source**

1. Turn the demand pump switch to OFF. (Chieftain & Sunflyer owners: Also be sure tank fill valve is closed.)

2. Attach a hose from the external water source to the city water connection on your vehicle. This connection is located on the left side of the vehicle, either on the sidewall or in a water system compartment.

3. Turn on the external water source.

City Water Connection

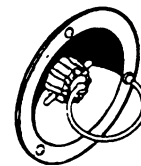

When connected to an outside source of water, the water bypasses the demand pump and storage tank and supplies pressure directly to individual faucets and toilet. A check valve built into the pump prevents water from entering the pump and filling the storage tank.

**To disconnect from the external source:**

1. Turn the external source off.
2. Open a faucet inside the vehicle to relieve line pressure.
3. Disconnect the hose from the vehicle and replace the cap on the connection.

**Flushing the City Water Connector**

The city water connector should be “back-flushed” periodically to avoid leakage or premature failure of the check valve assembly. Back-flushing the check valve will dislodge foreign particles and moisten the rubber plunger seal, allowing the valve to properly seat and form a complete seal.

To do this:

1. Attach a water hose to the city water connector and pressurize the vehicle’s plumbing system by filling the lines with water.
2. After the lines are full, disconnect the water hose from the city water connector.
3. Remove the screened washer from the hose coupler on the city water connector.
4. Step aside of the city water connector to avoid getting wet. Then depress the plunger inside the check valve to allow water to flow back out (“back-flush”) through the check valve.

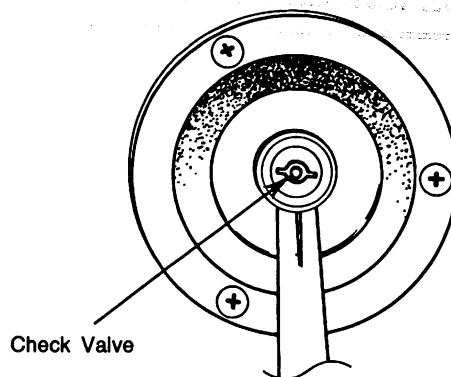

5. Repeat the previous steps as needed to ensure complete removal of any debris present inside the check valve assembly.

Do this procedure several times each season during use to keep the check valve operating properly.

### WATER TANK POWER DRAIN

The power drain is intended for rapidly draining the fresh water tank during preparation for storage or disinfection of the water system.

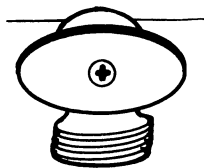

To Use:

1. Disconnect coach from city water supply, if attached.
2. Turn the water demand pump switch ON.
3. Open the power drain spigot.
4. When water flow stops, close the spigot to avoid unnecessary "dry" operation of the demand pump.
5. Drain remaining water from tank using the small tank drain valve at the floor of the water compartment.

The power drain may also be used to supply water to items outside the motor home, such as extinguishing campfires, if necessary. For best results, the water system should be connected to an external water source during this type of use.

### WATER DRAIN VALVES

The water drain valves are used to drain water from the water tank and the water supply lines when preparing the motor home for storage or when sanitizing the water system.

To open the valves, simply pull the rings upward approximately 1/2". To close, push the valve shafts downward until they are fully seated.

Drain valve locations are identified on page 7-6.

### SHOWER VALVE PRESSURE BLEED-OFF

After using the shower, you may notice water dripping from either the shower head or the faucet assembly. The dripping results when

vacuum in the shower hose (after closing the shower valve) slowly dissipates and allows water remaining in the hose to drain down. This is a normal water pressure bleed-off function of the shower valve assembly and is not a leak or defect.

The International Association of Plumbing and Mechanical Officials Standard TSC 21-85 (Par. 4.3) states:

"Shower heads which incorporate shutoff valves, shall have a minimum "drip rate" of one (1) quart in thirty (30) minutes."

### CAUTION

If items are placed into the shower tub before shower valve water pressure bleed-off is complete, they may become wet.

### DRAINAGE SYSTEM

The drainage system is self-contained, allowing use of the toilet, sinks, or shower even in areas where hook-up is not available. The drainage system may have two or three holding tanks depending on model and floor plan.

The holding tanks are dumped through a common outlet located on the left side of the vehicle, near the rear wheels.

On Chieftain, Sunflyer, Superchief and Sun-cruiser models, the sewage dump valves and outlet are located inside a compartment at the rear, driver side of the vehicle. The sewage hose may be routed through a passage in the floor of the compartment, allowing the door to be closed while attached to an on-site disposal. The hose may also be stowed within the compartment when not in use.

### DUMPING HOLDING TANKS

1. Remove drain hose from rear bumper or exterior storage compartment.
2. Remove dust cap from drain and connect drain hose. Be sure it is firmly attached.
3. Place the other end of sewer hose into disposal opening.

On Chieftain and Sunflyer models the dump outlet swivels up and down as shown for hose attachment and drain positioning.

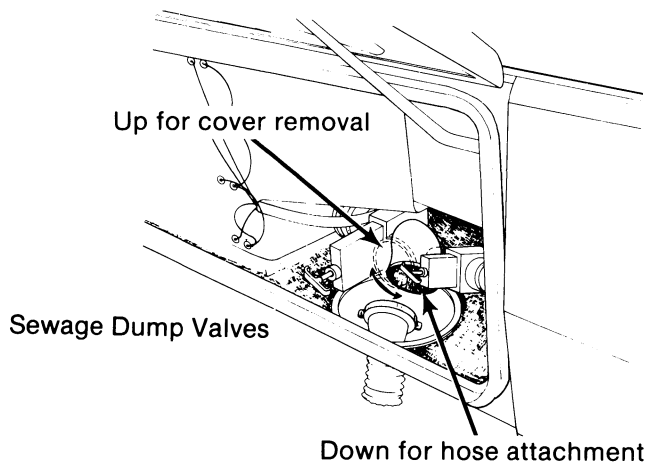

**NOTE:** If the waste drainage assembly has not been used for some time, the swivel action may become stiff and require extra effort to move. This condition will improve with use because water will lubricate the swivel joint.

4. Open the sewage valve with a quick pull. **OPEN ONE VALVE AT A TIME.** Move hose gently about to dislodge any waste and to ensure complete drainage.

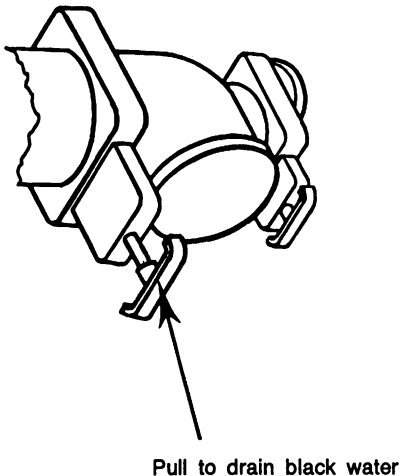
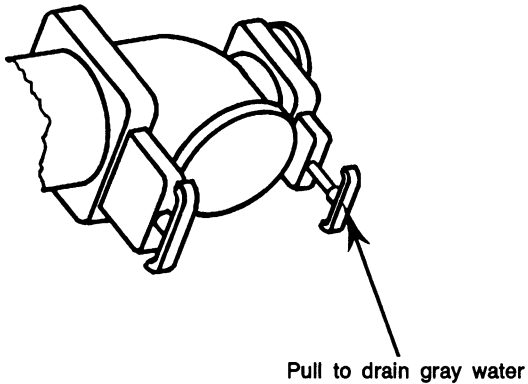

5. Close sewage valve and open waste water valve with a quick pull. Make sure there are no sags in the hose during drainage. Close valve handle as soon as tank is empty.
6. After both tanks have been drained, run several gallons of water into the sewage tank through the toilet. Then open sewage dump valve and drain the tank again. Close valve and securely replace dust cap.
7. It is advisable to add an odor control chemical to the sewage holding tank. These chemicals are available at most R.V. stores.
8. Rinse sewer hose thoroughly with water and stow.

**NOTE:** We recommend that you dump all holding tanks before traveling to avoid carrying unnecessary weight.

#### USING ON-SITE SEWER HOOK-UPS

The drain hose may remain attached to the dump outlet and be routed out the bottom of the compartment while the motor home is parked and connected to an on-site sewage hook-up.

When using a sewer hook-up, keep the dump valves closed until a tank becomes full or when preparing to leave the site. This keeps the solids in suspension, allowing them to be carried out with the liquids when the dump valve is opened. If the valve is left open, the liquids will drain off, leaving solids in the tank. Should this accidentally happen, disconnect the hose, fill the tank about half full with water, and drive a few miles to dislodge the solids. A few starts and stops will aid in the process. Then reconnect the hose and drain in the normal manner.

#### HOLDING TANK LEVEL INDICATORS

The holding tanks may be monitored on the range hood monitor panel or the wall mounted monitor center, depending on model and options.

Press the switches labeled H.T.1, H.T.2 or H.T.3 to check the level in each tank.

### WATER SYSTEM DRAIN VALVE LOCATIONS

MODEL	DRAIN VALVE LOCATIONS
Warrior 319RB Spirit 319RB	Under front dinette seat; under rear wardrobe cabinet; under water heater.
Warrior 321RG Spirit 321RG	Under shower, behind access panel; under water tank in bottom of refrigerator cabinet compartment.
Warrior 323RC Spirit 323RC	Under shower tub, behind access panel; under rear dinette seat.
Warrior 327RT Spirit 327RT	Under lavatory sink; under driver's side twin bed.
Warrior 22EC Spirit 22EC	Behind panel under shower; water tank power drain (faucet), access through panel in wardrobe.
Warrior 27EU Spirit 27EU	Under shelf in lavatory; water tank power drain (faucet), access through panel in wardrobe.
Chieftain 25RC Sunflyer 25RC	Under rear double bed; water tank power drain (faucet).
Chieftain 27RT Sunflyer 27RT	Under double bed or under both twin beds; water tank power drain (faucet).
Chieftain 31RQ Sunflyer 31RQ	Under wardrobe; water tank power drain (faucet).
Chieftain 33RQ Sunflyer 33RQ	Under bed; behind bottom drawer of driver's side wardrobe; water tank power drain (faucet).
Chieftain 36RQ Sunflyer 36RQ	Galley cabinet under range; under false floor in wardrobe closet; water tank power drain (faucet).
Superchief 27RQ Suncruiser 27RQ	In-line both sides demand pump (above LP tank in sub-floor); galley cabinet under stove.
Superchief 31RQ Suncruiser 31RQ	Rear luggage compartment both sides.
Superchief 34RA Suncruiser 34RA	Second luggage compartment from rear on passenger's side; behind water heater, access through luggage compartment passenger's side.
Superchief 40RQ Suncruiser 40RQ	Behind drawer below oven; sewage compartment (driver's side).
Elandan 32RQ Windcruiser 32RQ	Under galley; under ice maker (optional).
Elandan 37RQ Windcruiser 37RQ	Under queen bed; under wardrobe; under ice maker (optional).

## SECTION 8 APPLIANCES

(See also Safety Precautions, Section 1 of this manual.)

### IMPORTANT

Some items described in this section may be optional and, therefore, may not apply to your vehicle.

The appliances installed in your motor home are manufactured by reputable RV appliance makers and have been tested by independent laboratories to meet all applicable standards and codes set for RV appliances. These appliances should provide you with years of trouble-free service.

Most appliances are covered by your New Vehicle Limited Warranty. (Certain items may be covered by individual manufacturer's warranty.) See your New Vehicle Limited Warranty for details.

### REFRIGERATOR

The refrigerator in your coach can be operated from either of two power sources available to the motor home:

- 110-volt AC electric
- LP gas

This provides you with maximum assurance of food preservation in any location and while traveling.

The refrigerator is an absorption type which uses an ammonia-water solution for cooling. Basically, ammonia vapor is distilled from the solution by heat, produced from either LP gas or electricity and then carried to the finned condenser where it liquifies. The liquid flows to an evaporator where it creates cold temperatures through evaporation.

#### Leveling

Before operating the refrigerator when the motor home is stationary, place a small level on the freeze plate and make certain the unit is level.

### CAUTION

To obtain proper performance from the refrigerator and prevent damage to the cooling unit, make certain the motor home is level side to side and front to rear when parked. When the motor home is in motion, the continuous movement will not affect the refrigerator since the rolling and pitching action will prevent pockets of liquid from forming. If the motor home is parked in an out-of-level position for more than one hour, the refrigerator must be turned off.

Normal vehicle leveling to provide comfort for the occupants is satisfactory for refrigerator operation. This will be well within the operation limits of 3° off-level side to side and 6° off-level front to back.

#### Operation in Transit

While the refrigerator should be level when the vehicle is stopped, performance during transit is not normally affected.

### OPERATING INSTRUCTIONS

Your coach may be equipped with one of four models of Norcold 2-way refrigerators: Models 662, 682, 875, or 876. To correctly identify your model, check the serial plate located at the bottom front of the refrigerator.

#### Models 662 and 682 with Auto Mode Selector

##### Start-Up Instructions—Auto Mode

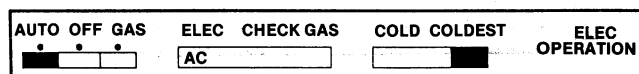

1. Move thermostat to COLDEST position. Set AUTO-OFF-GAS switch to AUTO.
2. If 120 volts is active, the panel will display AC, indicating refrigerator is operating in 120 volt AC mode.

- If 120 volts AC is inactive (power failure, disconnected, etc.), it will display LP, indicating refrigerator has automatically switched to LP gas mode.
- If the panel displays LP and a red X continuously, the refrigerator has failed to ignite burner on gas mode. Restart gas operation by moving AUTO-OFF-GAS switch to OFF and back to AUTO. (See steps 3, 4, and 5 under Gas Mode.) Note: Unit operation will automatically return to AC when 120 volts AC is restored, even if the unit is locked out on gas operation.
- Move thermostat to desired setting, usually a mid setting.

### Start-Up Instructions—Gas Mode

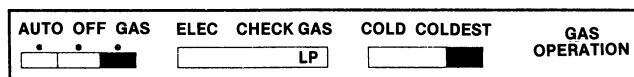

- Move thermostat to COLDEST position. Set AUTO-OFF-GAS switch to GAS.
- The panel will display LP, indicating LP gas mode. (If LP is not displayed, check for loss of DC supply voltage.) Initially, the red X will be displayed for about 5 seconds; after which, sparking will start at the burner and the red X goes off.
- After 10 seconds, the burner should be ignited and operating normally.
- On the initial refrigerator start-up, it may take longer than 10 seconds to allow air to be purged from the gas line. If gas does not ignite within 10 seconds, valve will automatically shut off and the red X will be displayed at the CHECK position.
- To restart when the X is displayed, move AUTO-OFF-GAS switch to OFF position, then return switch to the GAS position.  
DO NOT CONTINUE TO RESET GAS SWITCH IF THE CHECK INDICATION CONTINUES TO DISPLAY AFTER SEVERAL TRIES.

### Shut Down Instructions—Gas or Electric

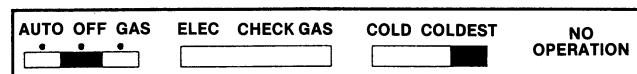

Short Duration: Set AUTO-OFF-GAS switch to OFF.  
Long Duration: Set NORMAL-STORAGE-HIGH HUMIDITY switch (located on divider between the two doors) to STORAGE.

### Location of Controls

The Mode Selector is located above the upper door and includes the thermostat for controlling the interior temperatures, the switches which select the operating mode, and the panel which continuously displays the selected operating mode. On the divider panel, located between the two doors, is the High Humidity and Storage switch. (See following paragraphs for a description.) The light switch is located in this area to automatically activate the cabinet light when the lower door opens.

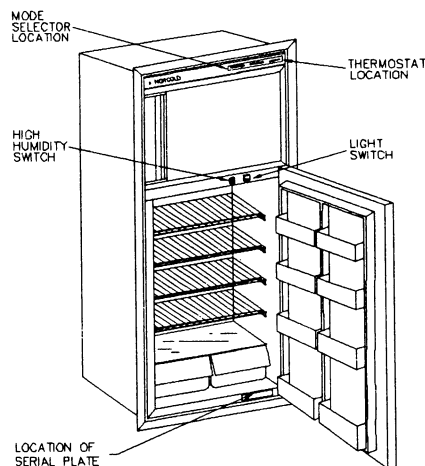

### Mode Selector

#### AUTO:

The refrigerator will operate on 120 volts AC so long as AC power is available to the refrigerator. If AC power is lost (or disconnected), the Selector will automatically switch to gas operation. As soon as AC power is restored, the Selector automatically switches back to AC operation. (The user does not have to manually switch the refrigerator back to AC.) When the operation is automatically switched to gas, the burner will ignite and continue to operate the refrigerator at the same thermostat setting as set for AC power. The gas operation assumes that an LP gas and 12-volt DC supplies are available.

#### GAS:

This selection allows the refrigerator to operate on LP gas only. It will not automatically switch modes regardless of whether AC power is connected or not. If the flame is lost (LP tank empty, etc.), the operation locks out and must be manually reset.

## Model 876EG2

### Lighting Instructions—Gas Mode

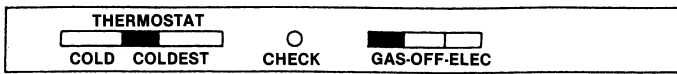

1. 12-Volt DC supply must be on in order to energize the direct spark ignition system.
2. Move thermostat to mid range position.
3. Move switch to GAS position. Sparking will start at burner and gas valve will open.
4. After 10 seconds, the burner should be ignited and operating normally.
5. On the initial refrigerator start-up, it may take longer than 10 seconds to allow air to be purged from the gas line. If the gas does not ignite within 10 seconds, valve will automatically shut off and the red (CHECK) light will come on.
6. To restart when the (CHECK) light is on, move switch to OFF position (center position) and wait 10 seconds, then move switch again to GAS position.

DO NOT CONTINUE TO RESET GAS SWITCH IF THE CHECK LIGHT CONTINUES TO COME ON AFTER SEVERAL TRIES.

### Start-Up Instructions—Electric Mode

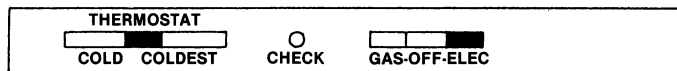

1. 120-Volt supply and 12-Volt DC supply must be on for refrigerator to operate on electric.
2. Move thermostat to mid range position.
3. Move switch to ELEC position.

### Shut-Down Instructions—Gas or Electric

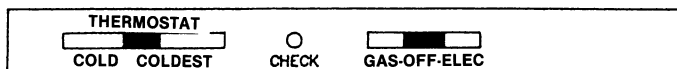

Refrigerator is shut down by moving switch to OFF position. Indicator light will be off.

### Mode Selector

If gas operation is desired, the user, by moving the switch to the gas mode, causes rapid sparking at the burner. If gas is present and safety controls are satisfied, the burner ignites and cycles according to the setting of the thermostat. The

refrigerator will continue to operate in the gas mode until the user selects either the electric mode or turns the refrigerator off. Likewise, by moving the switch for an electric mode causes operation in that mode provided the proper electric voltage is present.

### Location of Controls

The unit can be started or stopped with one switch which is located below the lower door. The thermostat control level is also located on this lower control panel to select the proper interior temperature.

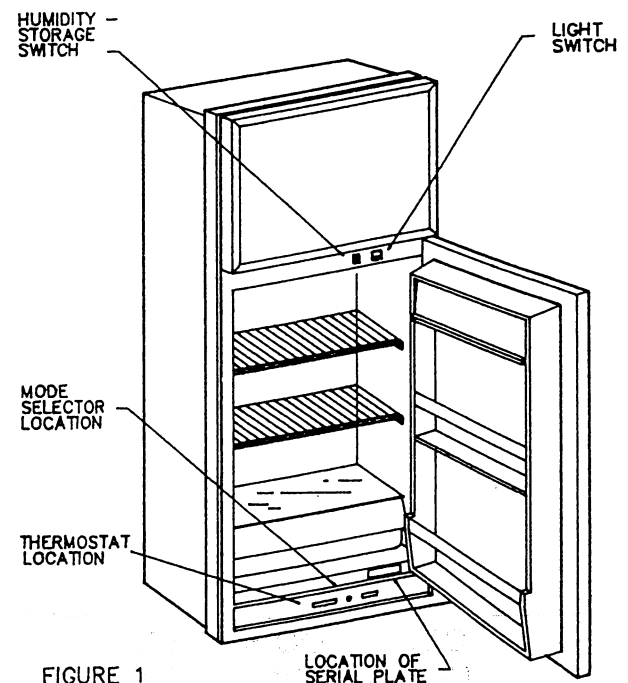

FIGURE 1

## Model 875EG2 (Single Door)

### Controls

2-Way refrigerators (875EG2) utilize a single combination control to determine and regulate the mode of operation (Gas or AC Electric). The control is operated by two knobs: the first, to select the operating mode (Gas or Electric); and the second, to control the thermostat setting. The control consists of a gas shut-off valve safety valve, thermostat and electric interlock. The interlock prevents the possibility of operating on gas and electric at the same time.

The safety valve is built into the combination control and is designed so that any loss of flame

will stop the gas flow to the burner. It is controlled by means of a thermocouple positioned in the gas flame. As long as a flame is detected by the thermocouple, the valve is held open. Upon flame failure (empty propane tank, blow-out, etc.), the valve closes, shutting off the gas flow. To light, or relight, the gas control knob must be pushed and held in until the ignitor establishes a flame (see "Lighting Instructions").

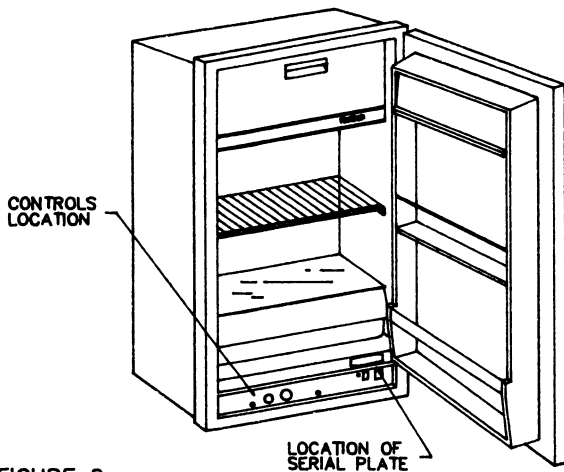

FIGURE 2

### Gas Operation

The gas burner is designed to operate on propane gas only. The gas control is equipped with an electric ignitor, offering the features of automatic re-ignition in case of flame blow-out, positive flame sensing, and easier gas start-up. The electronic ignition module, located behind the control panel, is powered by 12 volts DC and is controlled by the ignitor switch located on the control panel. When the switch is in the "OFF" position, no ignition spark is present. When the switch is in the "ON" position, the ignitor module produces a rapid spark at the gas burner. The spark occurs at a rate of 1 to 2 times per second until a flame is present. (Refer to Lighting Instructions.) The spark continues until a flame is sensed or until the ignitor switch is turned off. When the flame is sensed, the ignitor module automatically shuts off the spark and the flame indicator illuminates. Loss of flame causes the flame indicator to go off. During gas operation, the current draw is very low, approximately 30 milliamps (.030 amps).

### 120-Volt AC Operation

While parked, the coach normally operates from a 120-volt AC source. The refrigerator can be very easily switched to AC operation.

#### Quick Reference:

For Gas Operation:

- Propane gas must be available.
- 12 Volts DC

NOTE: 12 volts is necessary to automatically light or relight gas burner—see section on "Loss of 12-Volt Power."

- Controls set per "Lighting Instructions."

For AC Operation:

- 120 Volts AC (108 volts minimum).
- Controls set per "Start-Up Instructions."



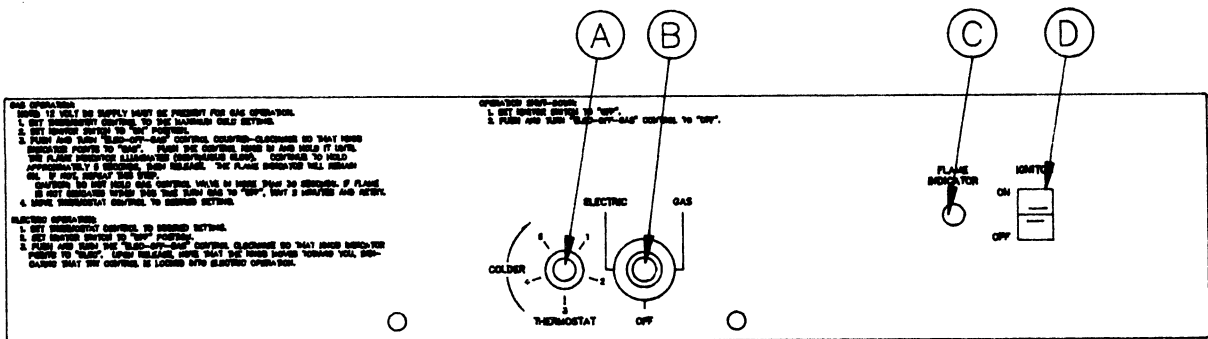

### Lighting Instructions—Gas Operation

(See Figure 1.)

1. Make certain that 12 Volts DC is available to the refrigerator.
2. Turn on gas supply at the tank.
3. Set thermostat control (A) to the maximum cold setting.
4. Set igniter switch (D) to "ON" position.
5. Push and turn the "ELEC-OFF-GAS" control (B) counterclockwise so that knob indicator points to "GAS." Push the control knob (B) in and hold it until the flame indicator (C) illuminates (continuous glow). Continue to hold approximately 5 seconds, then release. The flame indicator (C) will remain on. If not, repeat this step.

**NOTE:** The flame should ignite within 10 seconds. On initial refrigerator start-up, it may take longer than 10 seconds to allow air to be purged from the gas line, as indicated by the flame indicator (C) failing to illuminate.

**CAUTION:** Do not hold gas control valve (B) in more than 30 seconds. If flame is not indicated within this time, turn gas to "OFF," wait 2 minutes and retry.

6. Move thermostat control (A) to desired setting.
7. The igniter switch (D) should be left in the "ON" position during gas operation. If the switch is turned off, the refrigerator will cycle normally. However, in case of flame blow-out, the relighter does not function.

### Start-Up Instructions—AC Electric Operation

(See Figure 1.)

1. Make certain that both 12 Volts DC and 120 Volts AC are available to the refrigerator.
2. Set thermostat control (A) to desired setting.
3. Set igniter switch (D) to "OFF" position.
4. Push and turn the "ELEC-OFF-GAS" control (B) clockwise so that knob indicator points to "ELEC." Upon release, note that the knob moves toward you, indicating that the control is locked into electric operation.

### Operation Shut-Down, All Modes

1. Set igniter switch (D) to "OFF" position.
2. Push and turn "ELEC-OFF-GAS" control (B) to "OFF."

### Information (All Models)

#### Information Regarding Battery Drain

During gas operation, a 12-Volt DC source is required for operation on gas to provide features of automatic ignition. The current draw is less than 500 milliamps. If the humidity heater is also energized, this adds 240 milliamps for a total of 740 milliamps (.74 amps).

During AC operation there is, of course, no current drain for automatic ignition. The only DC volt current draw would be 240 milliamps (.24 amps) if the humidity switch is energized (assume the doors are not open).

Battery drain should also be considered during times when the refrigerator is stored, defrosted, or occasions when the door is left open. The interior light will draw 600 milliamps and the humidity heater, if left on, draws 240 milliamps for a possible current draw of 840 milliamps (.84 amps). In this case, the Humidity-Storage Switch should be pushed to the OFF position, thereby preventing any current drain (see description of storage switch).

### Mode Selector Utilization

The Mode Selector allows selection of either gas or 120-volt energy source.

Should you lose one of these sources, you can quickly switch to another source with the Mode Selector.

### Humidity—Storage Switch

Turning this switch to HIGH HUMIDITY will keep the surface between the door openings dry during high humidity conditions. The switch should be left in the NORMAL OPERATION position unless condensate is observed in this area.

When your RV is being stored for the winter, this switch should be put in the STORAGE (LIGHT OFF) position. This shuts off all DC power to the light and humidity heater and allows the refrigerator door to be left open for airing without chance of battery drain during storage.

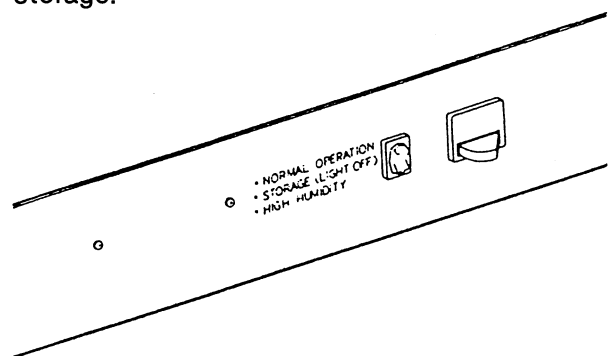

### REFRIGERATOR COMPARTMENT (Exterior)

The exterior refrigerator compartment allows access to the rear of the refrigerator for inspection, maintenance or service. The LP Gas Leak Gauge is also located in this compartment. (See LP LEAK GAUGE, Section 5.)

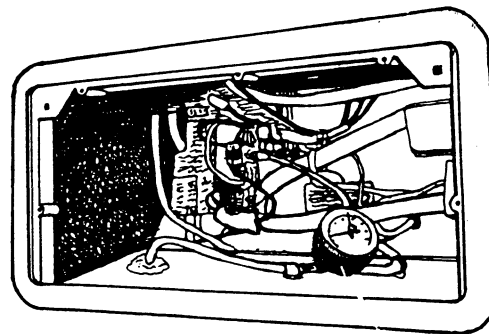

REFRIGERATOR ACCESS COMPARTMENT

### To Open:

1. Turn the latch knobs to the left 1/4 turn to the vertical position as shown.
2. Remove the door from the opening.

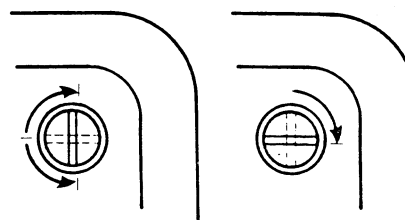

OPEN

CLOSE

REFRIGERATOR ACCESS DOOR LATCHES

### To Close:

1. Replace the door into the opening.
2. Push the latch knobs in while turning to the right 1/4 turn to the horizontal position as shown.

### RANGE AND OVEN

The range and oven in your motor home are operated on LP gas and will provide nearly all of the functions that the range in your home does. One of the features of gas burners is that heat is available as soon as a burner is lit, as opposed to an electric element heating up. The range has a "Pilot Off" position on the oven control which allows the oven pilot to be turned off when traveling or refilling the LP tank.

The following warning label has been located in the cooking area to remind you to provide an adequate supply of fresh air for combustion. Unlike homes, the amount of oxygen supply is limited due to the size of the recreational vehicle. Proper ventilation when using a cooking appliance will avoid danger of asphyxiation. It is

especially important that cooking appliances not be used for comfort heating as the danger of asphyxiation is greater when the appliance is used for long periods of time.

**WARNING**

IT IS NOT SAFE TO USE COOKING APPLIANCES FOR COMFORT HEATING

COOKING APPLIANCES NEED FRESH AIR FOR SAFE OPERATION. BEFORE OPERATION:

1. OPEN OVERHEAD VENT OR TURN ON EXHAUST FAN AND;
2. OPEN WINDOW.

**WARNING**

Portable fuel-burning equipment, including wood and charcoal grills and stoves, shall not be used inside the recreational vehicle. The use of this equipment inside the recreational vehicle may cause fires or asphyxiation.

**Use of Top Burners**

1. Light match.
2. Apply lighted match to burner.
3. Turn control knob left (counterclockwise to the full "On" position).
4. Adjust the flame height by turning the knob toward the "Off" position.

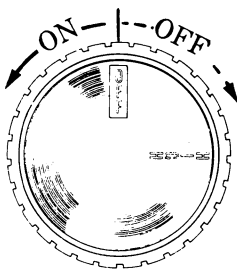

**WARNING**

Do not turn burner control knob to "On" and allow gas to escape before lighting match.

**LIGHTING OVEN PILOT**

NOTE: If range has not been operated for a long period of time, a longer waiting period for ignition of the pilot may be necessary due to air in the gas line.

1. Be sure all valves are in the "OFF" Position. The oven control knob should be in "OFF" position.
2. Turn on main gas supply to range.
3. Depress and turn control knob to the "OVEN PILOT ON" position. This will allow gas to oven pilot.
4. Open oven door and light oven pilot with a match. Small flame will be noted at the top of the pilot burner.

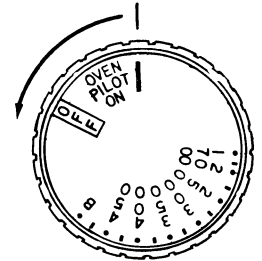
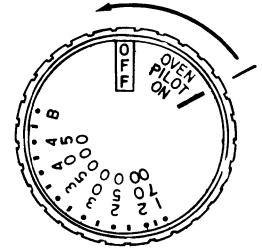

**Operating the Oven Control**

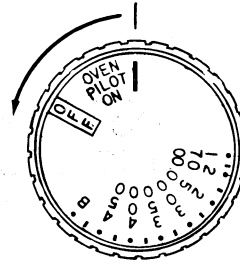

Depress and turn the oven control knob (counterclockwise) to the desired temperature setting. There is a delay of about 45 seconds before the main burner ignites. This is normal and there is no gas escaping during this delay. It is also normal for the oven burner flame to cycle off and on, at all set temperatures except broil.

**Shut Down Instructions**

When oven cooking is finished, turn the oven control knob to the "OVEN PILOT ON" position; the oven standby pilot will remain lit.

When the recreational vehicle is not in use or while traveling, turn the oven control knob to "OFF" position and turn off main gas supply; this will turn off the oven pilot.

## MICROWAVE OVEN (Optional)

For complete operating instructions, refer to the manufacturer's information provided with the oven.

## RANGE HOOD

The range hood vent allows you to exhaust cooking odors and gas fumes to the outside of the coach and to supplement fresh air ventilation. A light on the underside of the hood provides better illumination for food preparation.

## Monitor Panel—Range Hood Mounted

The monitor panel is incorporated into the face of the range hood. It provides centralized location of switches for the hood fan, hood light, water pump and tank level indicator lights. It also contains a digital clock with an alarm feature, which can be used as a cooking timer or simply for morning wakeup.

## Monitor Panel—Wall-Mounted

At the push of a single button this monitor panel simultaneously displays the coach battery condition and levels of the water tank, holding tanks and LP tank. It also contains the water pump power switch and an indicator light to show when the pump switch is on.

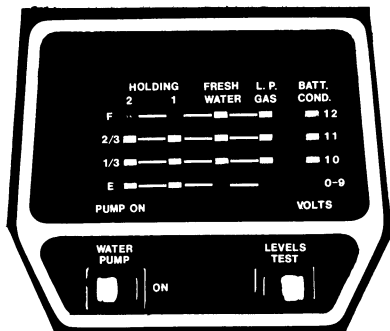

## Hood Fan and Light Switches

To turn on the range hood light, simply push the switch labeled "Hood Light." To operate the range hood fan, push the "Hood Fan" switch towards "High" or "Low" depending on the volume of exhaust desired.

## Water Pump Switch

When use of the self-contained water system is desired, turn the "Water Pump" switch on. The "Pump on" light will illuminate when the pump

switch is on and the system is operable. Water will be available as soon as a faucet is opened. Refer to "Fresh Water System" for additional information on the water pump and initial start-up.

## Water Heater Switch and "W.H. Out" Indicator

Be sure the water heater is filled with water before pressing this switch. To fill the water heater, turn the water pump switch on and open a hot water faucet until water begins to flow.

The "W.H. Out" light will glow for about 10-15 seconds after the water heater switch is turned on, then it will go off. If the light comes on during normal operation, it means that the burner has gone into "lockout" mode. Turn the switch off for about 5 minutes, then turn back on. See "Water Heater" elsewhere in this section for further information.

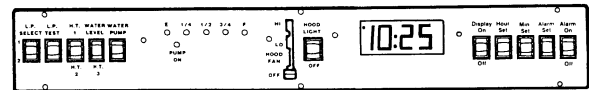

Range Hood/Monitor Panel

## Water and Holding Tank Levels

Press and hold the desired tank level switch to show approximate level on the monitor lights.

Approximate levels of the fresh water and holding tanks are measured by sets of electronic probes in the sides of the tanks. The liquid must be at or above a probe to illuminate the indicator lights to a given level.

For example, a water level of 1-2" above the 1/2 prove would register as only 1/2 full. Consequently, a level of merely 1" below the 1/2 probe would register as only 1/4 tank. So, generally speaking, there is actually more liquid in a tank than indicated.

## LP Gas Level

Press and hold the "LP Gas" switch to show approximate LP tank level.

The LP level is registered by a sending unit on the tank. The gauge mounted on the side of the tank will give a more accurate indication of actual tank level if needed.

## Digital Clock

To Set Clock Time:

- Press and hold "Hour Set" switch until desired hour appears. A small light at the left of the display will identify PM hours.
- Press and hold "Min. Set" switch until desired minute appears.

**To Set Alarm:**

- Press and hold "Alarm Set" switch while selecting hours and minutes with the "Hour Set" and "Min. Set" buttons.
- Turn "Alarm" switch to ON to engage alarm; OFF to disengage alarm.

You do not need to reset the alarm each time you turn it off. It will hold its current setting until deliberately changed or unless power is disconnected from the range hood.

**WATER HEATER**

**Direct Ignition Models G6A-6E, GH6-6E, and GCH6-6E**

1. Place Water Heater switch in the "On" position.
2. If "W.H. Out" light stays on longer than 15 seconds, place switch in "Off" position and wait 5 minutes.
3. Repeat step one.
4. For complete shut-down and before servicing:
  - a. Place Water Heater switch in "Off" position.
  - b. Remove red wire from left-hand terminal of ECO switch (ECO to valve).
5. If heater fails to operate due to high water temperature, the heater will go into a lockout condition ("W.H. Out" light on). When water cools, reset by placing switch in "Off" position for at least 30 seconds, then return to "On" position.
7. If a lockout condition persists: contact your dealer, an Atwood Service Station or Atwood Service Department (Phone: 815-877-7461).

**WATER HEATER**

**Pilot Models G6A-6, GH6-6, G4-6, GC6A-6, and G6A-6P**

**CAUTION:**

Do not tamper with the pilot orifice. High water temperature can result.

1. Turn lighting control to "Off" position.
2. Wait at least five minutes to allow gas which may have accumulated in burner compartment to escape.

**NOTE: For pilot relight model (G6A-6P):**

Turn the switch located on the spark module to the "On" position.

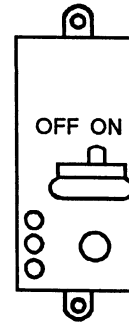

3. Note that your water heater may have either a Robertshaw "Unitrol" or "Jade" control.

**For a Robertshaw "Unitrol":**

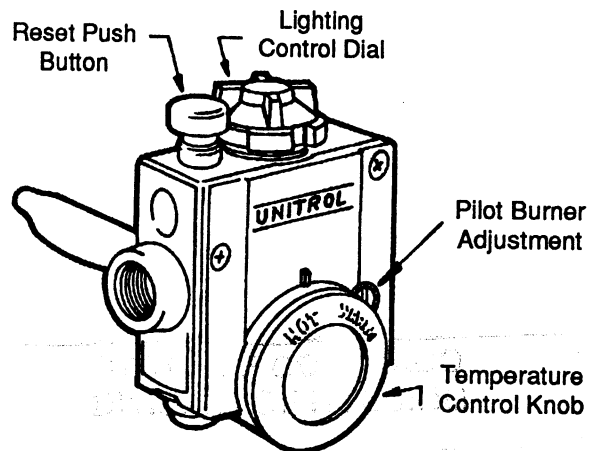

- a. Turn lighting control dial to "Pilot" position.
- b. Depress and hold reset push button while lighting pilot burner.
- c. Allow pilot to burn for one-half minute before releasing button.
- d. Turn control dial to "On" position.
- e. If pilot does not remain lit, repeat operation, allowing longer period before releasing push button.
- f. Set the dial at the mid-point position between warm and hot.
- g. Close access door.

### For "Jade" Control:

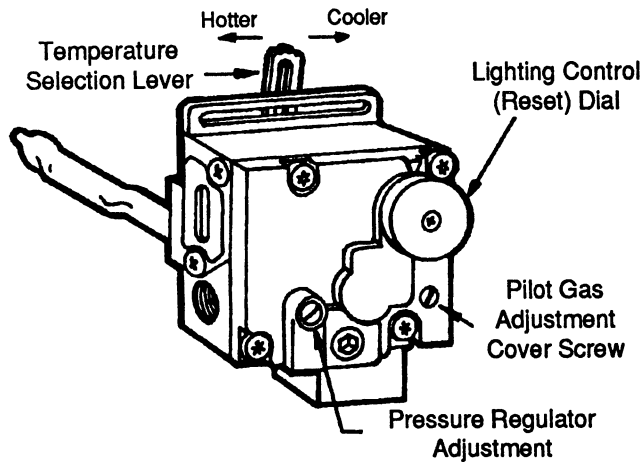

- a. Turn lighting control dial to "Pilot" position and hold against stop while lighting pilot burner.
  - b. Allow pilot to burn approximately one-half minute before releasing dial.
  - c. Turn control knob to "On" position.
  - d. If pilot does not remain lit, repeat operation, allowing longer period before releasing button or knob.
  - e. Set the lever at the mark between the warm and hot position.
  - f. Close access door.
4. For complete shut-down and before servicing, turn lighting dial to "Off" position.

### CAUTION:

The temperature knob or lever is factory adjusted to its lowest dial setting. We recommend the mid-point position between warm and hot, as noted above. This will provide for energy efficient operation and sufficiently hot water. Setting at a higher position will produce a higher temperature and increase the risk of being scalded.

### Water Heater P-T Relief Valve

On occasion, water may be seen seeping from the water heater pressure temperature relief valve. This is no cause for repair or replacement of the valve.

Normally, there is an air gap at the top of the water heater tank which acts as a pressure buffer. In time, however, expanding water may absorb this air gap, causing a slight increase in

pressure. This may cause the P-T valve to "weep" until the air gap is replaced manually.

### To Replace the Air Gap:

1. Turn off the water heater switch and incoming water supply (city water and/or demand pump).
2. Open a faucet in the motor home.
3. Pull the handle of the P-T valve straight out and allow water to flow until it stops.

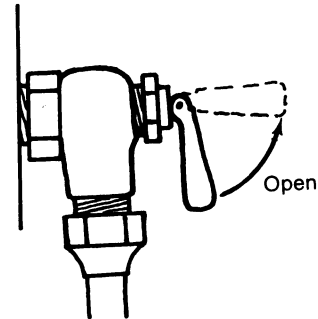

P-T VALVE

4. Let the handle of the P-T valve snap shut.
5. Close the faucet and turn on the water supply before switching the water heater on.

Manually operate the pressure thermostat relief switch at least once a year. **OPERATE THIS VALVE ONLY WHEN THE WATER HEATER AND COOLING SYSTEM ARE COLD!**

### MOTOR AID (Optional)

The motor aid acts as a heat exchanger between the water heater and the vehicle engine. Two hoses from the water heater connect to the hoses which deliver hot water between the engine and the driver's compartment heater. A heat exchanger in the water heater then circulates the water from the engine radiator around the water heater tank. Under normal conditions, the entire contents of the water heater tank will be heated to approximately 140° F in about two hours or 100 miles of driving.

In addition, the motor aid heat exchanger helps the vehicle engine to operate at cooler temperatures by dissipating heat from the engine. This reduces the possibility of overheating, particularly when operating in hot climates.

## CAUTION

Any leak in the heat exchanger or its supply or return lines could cause loss of coolant and subsequent engine failure. We recommend that the user make frequent inspection of these connecting lines and the heater to insure that no leaks have developed.

### Motor Aid Water Heater and Rear Auxiliary Heater Maintenance

Have your authorized dealer check all hose clamp connections on the rear automotive heater and the motor aid water heater at least every six months and tighten them if necessary.

### LP GAS FURNACE (Suburban)

#### OPERATING INSTRUCTIONS

1. Turn the manual valve to the "OFF" position. Do not force.
2. Move "OFF" lever located at bottom of thermostat to the right if set on "OFF" position.
3. Set thermostat above room temperature to begin blower operation. A slight delay will occur before the blower comes on. Allow blower to run for 5 minutes for combustion chamber purge cycle.
4. After 5 minutes, move thermostat lever below room temperature. Blower will remain on. Wait approximately 2 minutes for blower to go off.
5. Open manual shut-off valve. Correct operating characteristics depend on this valve being positioned fully open. Never attempt to operate with valve partially closed.
6. Set thermostat lever to desired setting. If set above room temperature, blower will come on.
7. Allow 30 seconds for main burner to light after blower comes on. This furnace is equipped with an ignition device which automatically lights the burner. Do not try to light the burner by hand.
8. If burner does not light, repeat Steps 1 through 5.
9. If after three (3) attempts with no ignition, go to shut-down and contact your dealer or a local recreational vehicle service agency. Do not continue to cycle furnace through thermostat in an attempt to get ignition.

#### TO SHUT DOWN:

1. Set thermostat to positive "OFF" position. (Move "OFF" lever on bottom of thermostat to "OFF" position.)
2. Turn manual shut-off valve to the "OFF" position. Do not force.

### ROOF AIR CONDITIONERS

Refer to the manufacturer's information in your Motor Home Operations Manual binder for complete operating instructions.

### AIR CONDITIONER SELECTOR SWITCH (Vehicles with Two Roof Air Units)

In Chieftain and Sunflyer vehicles the selector switch is located in the circuit breaker compartment above the refrigerator. In the Superchief DX/L and Suncruiser DX/L vehicles the selector switch is located on the lower galley cabinet face in the side aisle. In all other vehicles the selector switch is located on a cabinet face near the electrical power converter.

Since an external 110-volt power source (shoreline hook-up) can only handle operating one roof air unit at a time, the selector switch is provided to allow you to select the unit of your choice—front or rear.

Both room air units can be used at the same time in vehicles equipped with 6,500 or 7,000-watt auxiliary generators if a 110-volt shoreline is plugged into the auxiliary generator.

To allow generator start-up without excessive load, follow these steps:

1. Be sure both roof air units are switched OFF.
2. Start the generator.
3. Turn the A/C selector switch to the FRONT position. OCT 3 1 1989
4. Switch both roof air units ON.

### FRONT A/C THERMOSTAT (Elandan and Windcruiser models only.)

The front roof air unit on these models is controlled by a thermostat on the wall near the galley. Some models use a single thermostat with a dual Heat/Cool switch. Other models have two thermostats—one for the roof air unit and one for the furnace.

### TV ANTENNA

The TV antenna on your motor home can be easily raised, rotated a full 360° and lowered from inside the vehicle by simply turning a crank or rotating disc. Some models have a built-in

signal amplifier designed to strengthen signals, which is controlled by the power switch built into the TV jack assembly.

The amplifier is housed inside the antenna with the circuit board connected directly to the antenna elements. Power to operate the amplifier (12-volt DC) is supplied through the downlead cable which also carries the TV signals to the TV set. The power supply separates the 12-volt DC from the TV signals and provides a place for attaching the TV set and the 12-volt power source.

**Operation**

**Raising Antenna**—Turn elevating crank (clockwise) in “UP” direction about 13 turns or until some resistance to turning is noted. Antenna is now in operating position. Check to assure power supply switch is “ON.”



**Rotating Antenna**—Make sure antenna is in the “UP” position. Pull down on rotating knob until it disengages ceiling plate and rotate for best picture and sound on TV set.



**Lowering Antenna to Travel Position**—Rotate antenna until pointer on rotating knob aligns with pointer on ceiling plate.

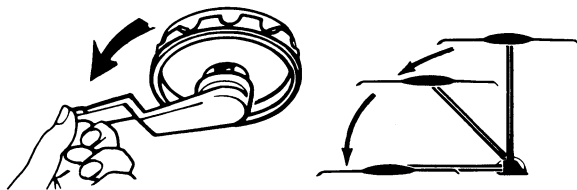

**CAUTION**

Never lower antenna to any position except travel position.

Turn elevating crank (counterclockwise) in “DOWN” direction until resistance is noted. Antenna is now locked in travel position. Return power supply switch to the “Off” position.

Count number of turns necessary on elevating crank to lower antenna until head is just resting on the roof of the vehicle. Mark position of elevating crank on ceiling or directional handle and number of turns (about 13). Use this number of turns when raising or lowering and stop at mark.

**CAUTION**

Always align directional handle to “DOWN” position before lowering.

**Amplifier**

To operate amplifier, turn on power switch.

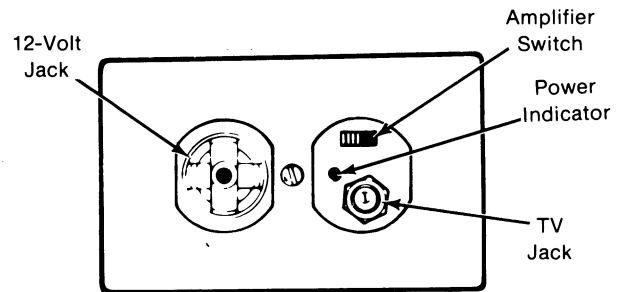

12-VOLT AND TV JACKS

The TV jack plates are mounted in various locations throughout the coach. Three of these wall plates are not readily visible and are located as follows:

- Beneath passenger side of the dash.
- Behind pull-down TV shelf/mirror in bedroom.
- In middle exterior storage compartment.



**Checking Performance**

The TV signals available to an RV are entirely dependent on its location with regard to the transmitter. Signals may vary from very strong to no usable signal at all. We recommend that the TV system be checked out in an area known to have good TV reception.

**WARNING**

Observe antenna height while parked, to prevent contact with electrical wires, power lines, etc.

1988  
OCT 31 1989

## SECTION 9

# INTERIOR FEATURES AND FURNISHINGS

(See also Safety Precautions, Section 1 of this manual.)

### IMPORTANT

Since Winnebago and Itasca motor homes are available in a wide variety of models and floor plans, some items described may be optional or unavailable on your vehicle.

### SLEEPING FACILITIES

#### WARNING

Sleeping facilities are not to be utilized while vehicle is in motion.

Latch the pull-down bunk securely in position when the vehicle is in motion or when the bunk is not in use. Do not use for storage.

#### FRONT PULL-DOWN BUNK (A-Body)

##### To Lower:

1. Recline the driver and passenger front seats.
2. Pull the front privacy curtain ahead to increase side clearance.
3. Be sure sunvisors are against the windshield.
4. Release the latches at the rear of the bunk. (Push up center button of latch to unlock latch handle.)
5. Using the strap handle, pull the bunk downward into position.

##### To Raise:

1. Remove any items from the bunk which could contact the ceiling or otherwise prevent the bunk from fully retracting.
2. Lift the bunk upward into the stored position and refasten the latches.

#### OVERHEAD BUNK (C-Body)

The overhead bunk is located above the driver's compartment. While in the stored position, it allows easy access to the front seats from the living area of the motor home. It conveniently

and easily converts to a full-size bed as described below.

1. To convert to a bed, grasp the loop on the top section of the mattress and carefully unfold to cover the driver's compartment.
2. To stow the bed while not in use, fold the rear mattress section forward onto the front section.

### COUCH/BED CONVERSIONS

#### Continental Bed

##### To Convert Couch to Bed:

1. Remove the backrest cushions from the couch.
2. Grasp the front edge of the couch and pull upward and outward from the wall at the same time.
3. Lift the front edge of the seat cushion and unfold it toward the wall until it lies flat, forming a sleeping surface.

##### To Revert to Couch:

1. Fold the mattress forward from the wall to return the seat cushions upright.
2. Pull the front of the couch upward and push in toward the wall at the same time until fully seated against the wall.
3. Place the backrest cushions in their original locations.

#### Presto Bed/Shrock Bed

##### To Convert Couch to Bed:

Pull the front edge of the couch seat upward and outward from the wall while gently pushing downward on the backrest until the cushions lay flat. The bed is now ready for use.

##### To Revert to Couch:

Push the front edge of the seat toward the wall while lifting upward on the backrest until the couch is fully seated against the wall.

### DINETTE/BED CONVERSION

##### To Convert Dinette to Bed:

1. Release the catch on the table leg brace and fold the leg up against the bottom of the table.

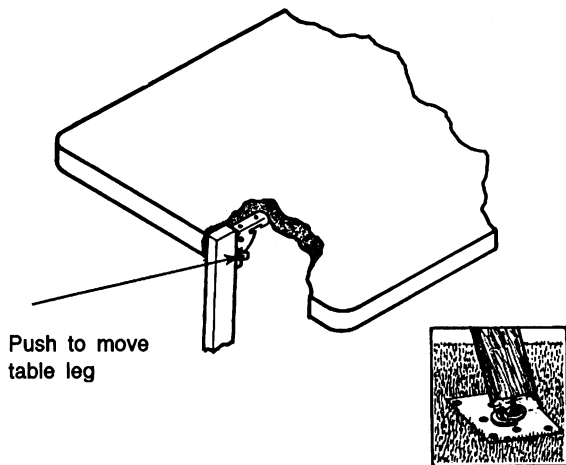

2. Remove the table from the wall support bracket by lifting the end of the table. Then lower the table to rest on the cleats attached to each dinette bench.
3. Arrange dinette cushions to cover bed area.

**To Revert to Dinette:**

1. Replace table onto the wall support and lower the table leg.
2. Make sure that the table leg is secured into the floor support bracket and the leg brace is locked.

**FOLD-UP LAVATORY SINK (Model 321RG only)**

The fold-up lavatory is designed to store against the wall as a space-saving measure when not in use. The sink is equipped with a dual control sink faucet and hand-held shower head. It uses a unique drainage system similar to that of railroad pullman cars.

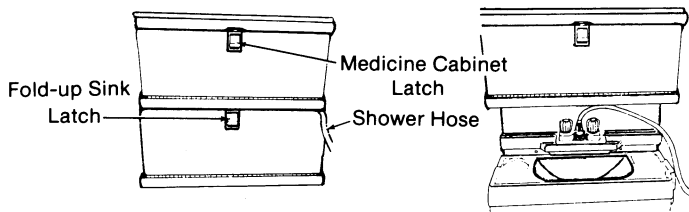

**To Use:**

Release the latch which secures the lavatory against the cabinet and lower the lavatory into position.

**To Drain and Store:**

Raise the front edge of the lavatory toward the wall and fasten the latch. The water contained in the basin will flow into a concealed drain cavity behind the lavatory cabinet.

**FRESH WATER TOILET**

The fresh water toilet in your motor home is very similar to the household type, except that it is designed to use only a small amount of water per flush. It uses a high velocity jet of water, producing a swirl effect, to efficiently cleanse the bowl. And since each flush uses fresh water, no special chemicals are required other than a deodorizing agent, if necessary.

**Thetford Model SL Toilet**

1. To add water to the bowl before using, step on the small pedal at the base of the toilet. Hold until the desired water level is reached. Generally, more water is required only when flushing solids.

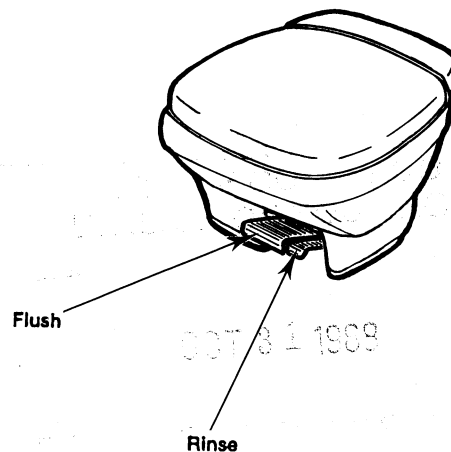

2. To flush the toilet, step on the large pedal, which opens the flush valve and begins rinsing. Hold pedal until bowl is clean.
3. Release flush pedal. A small amount of water should remain in the bowl.

Please refer to the manufacturer's information supplied with the toilet for further operating and maintenance instructions.

## Porcelain Toilet

1. To add water to the toilet before using, lift the flush lever until the desired water level is reached. Generally, more water is required only when flushing solids.

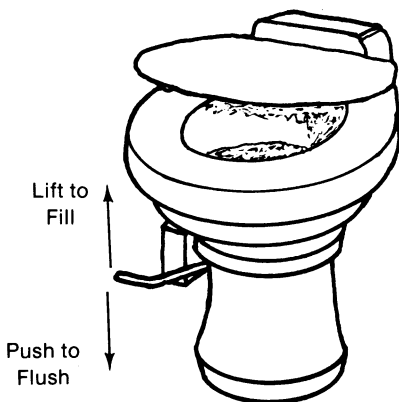

2. To flush the toilet, push the lever all the way down until sewage leaves the toilet and bowl is rinsed clean.
3. Release the flush lever. A small amount of water should remain in the bowl.

Please refer to the manufacturer's information supplied with the toilet for further operating and maintenance instructions.

### Important "Don'ts"

- Don't use facial tissue or regular toilet tissue in the RV toilet. These will not disintegrate sufficiently and will often cling to the sides of the holding tank. Toilet tissue made specifically for use in RV toilets and holding tanks is available at most RV supply centers.
- Don't dispose of sanitary napkins or other non-dissolving items in the toilet.
- Don't put automotive antifreeze or caustic chemicals, such as laundry bleach or heavy detergents into the toilet or holding tank. These products may damage plastic or rubber parts in the system.

### Cleaning the Toilet

The toilet should be cleaned regularly for maximum sanitation and operating efficiency. If an odor is apparent from the toilet:

1. Clean the toilet bowl with a mild bathroom cleaner. Do not allow cleaners to set in the bowl for long periods of time to avoid damaging the seals.

Do not use caustic or abrasive cleaners in the Thetford toilet since it may damage the plastic surfaces.

2. Dump and rinse holding tank.
3. Add odor control chemical in amount specified after cleaning and every few days during use.
4. Remove the water line from the base of the toilet and clean the screen.
5. If the flush valve becomes stiff after extended use, it may be lubricated with a silicone spray. Turn the water pump off and operate flush pedal/lever to drain water from the toilet bowl. Spray silicone lubricant onto flush valve inside bowl and operate flush pedal/lever a few times to ensure free operation.

See instructions in Section 11 to prepare the toilet for storage in freezing conditions.

## SHOWER MOUNTED CLOTHES ROD

Your motor home may be equipped with a removable clothes rod mounted in the shower stall. This convenience allows for drying of wet or damp bathing towels, swim wear or other articles, and may be used as temporary storage for a limited number of light clothing articles. We recommend removing all articles from the clothes rod while the vehicle is in motion.

### CAUTION

Total weight of all articles suspended from the clothes rod must not exceed 35 lbs. Permanent damage to the clothes rod or the shower stall may result if the clothes rod is overloaded.

## POWER ROOF VENT—Bath Area

Some models are optionally equipped with a powered roof vent in the bath area. The switches which control the vent lift and the fan are typically located on the aisle side of the lavatory cabinet.

## POWER ROOF VENT—Galley Area

Some models may be optionally equipped with a powered roof vent in the galley area of the motor home.

A switch on the vent panel controls fan on/off and fan speed. When the fan speed selector is in any of the three ON positions (Lo-Med-Hi), the

fan motor will start automatically as the dome is raised. The fan will stop when the dome is closed.

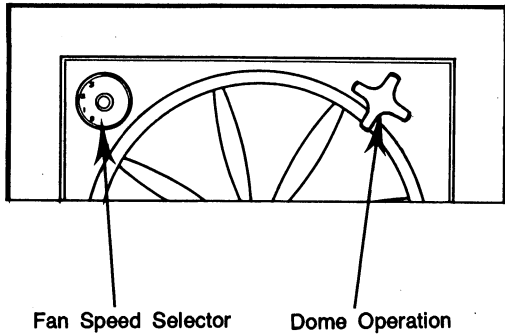

If the fan is not desired, turn the selector to OFF.

### CRANK-OUT SIDE WINDOWS

Turn the crank-out knob clockwise to open window; counter-clockwise to close. Do not use excessive force on the knob to open or lock into closed position. This could cause permanent damage to the crank mechanism.

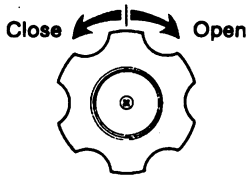

If the window will not open after three or more full turns of the knob, the glass may be stuck to the sealing gasket. Go to the outside of the coach and **gently** free the glass with your fingers. A periodic light dusting of talcum powder on the gasket should prevent this from recurring.

OCT 21 1989

## SECTION 10 CARE AND MAINTENANCE

### CAUTION

Sealants must be inspected every 6 months and resealed if necessary.

### ROOF

The roof utilizes Thermo-Panel® construction like the walls and floor. It will support the weight of an average adult should it become necessary to repair the roof or roof mounted components. It is not recommended, however, that very large or heavy objects be carried on the roof while the vehicle is in motion. Always have damage to the roof area repaired immediately. Damaged or detached sealant around the vents, air conditioner, body-to-roof seams, etc., should also receive immediate attention. Delaying these repairs may allow water leakage and result in damage to interior ceiling and body panels, upholstery, etc.

### UNDERBODY

Buildup of mud under the body can not only cause rust, but add unnecessary weight which contributes to the gross weight of the vehicle. This, in effect, reduces the amount of cargo you can carry and remain within GVWR and GAWR limits.

Corrosive materials, such as those used for ice and snow removal and dust control, also accumulate on the underside of a vehicle. These materials should be removed by flushing the underbody regularly with water, especially areas where mud and other foreign materials collect.

### EXTERIOR

The exterior surface of your motor home has an automotive finish. Frequent washing and thorough cleaning is recommended to prevent damage to the vehicle finish after exposure to damaging salts, calcium chloride, road tar, tree sap, insects and other foreign material. Never wash the vehicle in direct sunlight, while the vehicle surface is hot, or using hot water.

Do not use strong soaps or detergents for washing the motor home. Always use a mild soap in warm water, a commercially prepared product for cleaning automotive finishes or your local car wash.

After washing the motor home, carefully inspect caulking around window frames and vents and any other joints that may have separated. Re-caulking, if necessary, is quite simple. Appropriate compounds are sold at Winnebago/Itasca dealers, and the materials are quickly and easily applied. Also, inspect weather seals around door, etc., and if necessary have a dealer replace them immediately.

### CAUTION

Never use a strong solvent such as lacquer thinners or harsh abrasives on painted surfaces.

It is recommended that a coat of automotive wax be applied to the surface occasionally to provide added protection against harmful deposits coming in contact with the paint.

### UPHOLSTERY, CARPETING AND DRAPERIES

#### Upholstery and Carpeting

We recommend a weekly routine of vacuuming all fabrics and carpet throughout the motor home to prevent an accumulation of soil which can detract from the appearance and shorten the life of carpet and fabrics.

Some fabrics used in this motor home may contain fire retardant and lightfastness additives which can be damaged by use of improper cleaning agents. Some water-based household cleaning agents are not formulated for use on fabrics and may cause excessive shrinkage or fading. Always test any cleaning agent on a hidden area of fabric before using on visible areas. For best results, fabric cleaning should be referred to a professional carpet and upholstery cleaner.

#### IMPORTANT

**To minimize fading of upholstery, carpets and other interior fabrics caused by excessive sunlight, the drapes, blinds or shades should be closed when the motor home is parked for an extended period of time.**

## WARNING

When cleaning upholstery, carpeting and fabric, do not use lacquer thinner, nail polish remover, laundry soaps, or bleach. Never use carbon tetrachloride, gasoline, or naphtha for any cleaning purpose. These materials may cause damage to the material being cleaned and most are highly flammable.

### Spots and Stains

Spots or stains should be treated as soon as possible before they "set in" to avoid permanent damage. Always start from the outside of a spot or stain and work inward to avoid spreading it. Use a clean cloth or sponge and turn frequently to an unused area of the cloth or sponge as you clean.

Some stains or soils, such as lipstick, ink, grease or mustard, are extremely difficult or impossible to remove completely and should receive immediate attention. Consult a professional carpet and upholstery cleaner for assistance.

### Vinyl Fabrics

Vinyl should be cleaned with a soft, damp cloth and a mild detergent only. Do not use solvents. Solvents may damage the surface of the vinyl.

### Draperies, Curtains and Bedspreads

These items may be woven from a variety of fabrics. We recommend that these be professionally dry cleaned only. A five percent shrinkage may occur when you have these items dry cleaned.

### CABINETRY

Wooden items may be cleaned with a soft cloth and a good quality wood finish cleaning product such as Pledge,<sup>TM</sup> Liquid Gold,<sup>TM</sup> etc.

Vinyl simulated wood (Plus-Wood<sup>®</sup>) panels may be cleaned with a mild, water-based cleaner and a soft cloth. Do not use solvents on vinyl wood panels.

**NOTE:** Many cabinetry and furniture items throughout this motor home are constructed either partially or completely of real hardwoods. Because of natural variations in woodgrain density, slight differences in stain hue may exist between one item and another. This is the distinctive character and beauty of real wood.

### TABLES AND COUNTERTOPS

Work surfaces are covered with a plastic laminate that is resistant to solvents, stains and abrasions. A coat of furniture wax applied to these surfaces on the counters and table will help preserve their beauty and make cleaning easier. Always clean the surface before applying wax.

### AVONITE<sup>®</sup> COUNTERTOP

The galley countertop on some models is made of Avonite,<sup>®</sup> a plastic/fiberglass composite material which is extremely durable and may be refinished by trained personnel if damaged by minor scratches, nicks or chips.

### STAINLESS STEEL SINK

The stainless steel sink can be cleaned with soap or detergent. Rinse thoroughly with warm water and wipe dry to avoid streaks.

Use a mild abrasive for stubborn stains. Work in the direction of the polish lines. To keep the original finish, polish with a wax cleaner and rub with a dry soft cloth.

## WARNING

Salt, mustard and mayonnaise may cause pitting. If spilled, clean immediately.

### RANGE AND REFRIGERATOR

For care and appearance maintenance of the range and refrigerator, refer to the operation and maintenance manual for each of the individual appliances included in your Motor Home Operation Manual binder.

## FLOORING—PARQUET WOOD

The wooden parquet flooring in the galley area is finished with a durable, polyurethane coating. To keep it clean, sweep or vacuum regularly. Buff with a soft bristle brush periodically to renew the shine. **Never damp mop.** Wipe spills immediately with a dry cloth.

## BATHROOM

The shower walls in the bathroom should be cleaned with a mild soap and water solution, or (to obtain maximum luster) use a good quality wax cleaner. Do not use an abrasive cleaner on the shower walls. However, a mild abrasive cleaner may be used to clean the shower floor or bathtub. If the shower has a Plexiglass door, it is extremely important that abrasives not be used. Solvents and aromatic spirits that contain a petroleum base or additive should also not be used. These products can cause a reaction with the glass that results in visible deterioration marks. Use only a mild detergent and water solution with a soft cloth to clean Plexiglass surfaces.

The bathroom lavatory is also a molded plastic material and should be cleaned with a mild soap and water solution. Abrasive cleaners or harsh detergents should not be used.

For instructions on the care of your fresh water toilet, refer to the information in your Motor Home Operation Manual binder.

## WASHERLESS FAUCET O-RINGS

Your coach is equipped with washerless faucets for greater reliability. Over time, however, even washerless faucets may begin to drip. This is because water mineral deposits or other foreign debris may damage the O-ring seals. To accommodate this possibility, all 2-knob lavatory faucets\* are supplied with an extra set of O-rings for faucet leak repairs. These are located beneath the knob caps, labeled "HOT" and "COLD." To access, pry the caps off gently using a small screwdriver or penknife blade.

\*Also the galley faucet on some models.

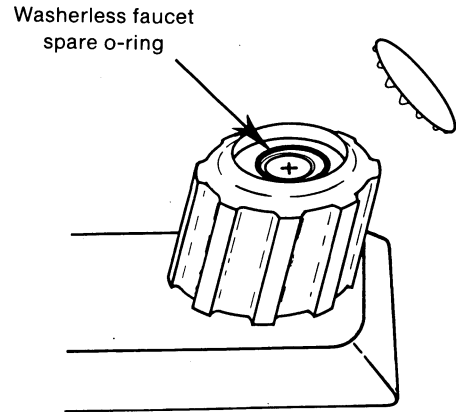

## DOORS AND WINDOWS

Windows may be periodically cleaned with a good quality glass cleaner or mild soap solution using a soft cloth. Use care when removing ice or frost from the windows. Always use a plastic ice scraper, never one made of metal. Use care when removing ice from the mirrors to protect the reflective surfaces.

Door locks and hinges should be lubricated periodically with powdered graphite to ensure trouble-free operation and to protect against freeze-up.

## WINDOW ROLL-UP SHADE ADJUSTMENT

If a roll-up type window shade in your motor home does not roll up or down fully, the spring tension may need adjustment.

### Spring Too Weak:

- Roll shade about half-way down on window.
- Remove shade from bracket.
- Roll shade snugly by hand and replace onto bracket.

### Spring Too Strong:

- Roll shade all the way up.
- Remove shade from bracket.
- Unroll shade one or two turns as necessary by hand and replace onto bracket.

## PLEATED WINDOW SHADE ADJUSTMENT

Pleated shades will lose their shape if left in a lowered position for an extended period of time. If a pleated shade loses its shape, storing it in the fully raised position for a while will reshape it. We recommend that you fully raise pleated shades when they are not in use, especially in warm environments, to prevent them from losing their shape.



## VEHICLE MAINTENANCE

(See also Safety Precautions, Section 1 of this manual.)

### CHASSIS SERVICE & MAINTENANCE

Consult the appropriate sections in your vehicle chassis manual for specific information regarding operating safety, service recommendations and maintenance schedules for the chassis section of your motor home.

### ENGINE ACCESS (C-Body)

Refer to your vehicle chassis manual.

### ENGINE ACCESS (A-Body Motor Homes)

#### Hood

The hood release lever is located on the steering column bracket near the bottom of the dash. To open, pull out on the knob and the hood will pop open. Lift up the hood and secure it with the hood support rod.

With the hood open, the oil dipstick, oil fill, radiator fill, power steering reservoir and windshield washer reservoir are accessible. On Elandan and Windcruiser, the automotive battery is also accessible.

#### IMPORTANT

When closing the hood, push down firmly to ensure that it latches properly and test by attempting to pull up on it.

#### Engine Cover

Remove the four (4) bolts securing the engine cover to the floor of the driver's compartment and lift cover off to gain access to engine.

Removal of the engine cover allows access for servicing the transmission dipstick and fill tube, engine air cleaner and other engine parts.

### ENGINE COOLING SYSTEM

Refer to your vehicle chassis manual for information and precautions in filling, servicing and checking the fluid level.

## CAUTION

When refilling the coolant system of a vehicle equipped with a rear auxiliary automotive heater and motoraid water heater, be sure to allow for additional coolant capacity of the heater and its supply and return hoses.

## TIRES

Low air pressure results in tire overloading and abnormal wear and also affects handling and fuel economy. Obtain proper inflation pressures from your vehicle chassis manual or tire manufacturer.

## WARNING

Radial ply tires are optional on some models. The tire option is not intended to upgrade the load rating of the entire vehicle and does not imply that GVWR and GAWR ratings may be increased over the figures found on the certification label.

Make sure all replacement tires are of the same size and ply rating as those installed as original equipment.

## SUSPENSION ALIGNMENT AND TIRE BALANCE

The front suspension and steering system of this vehicle was factory aligned using highly accurate equipment prior to delivery to the dealership. However, we recommend that alignment be checked and, if necessary, adjusted after the owner has fully loaded the motor home according to his needs. Thereafter, the alignment should be periodically inspected to help prevent uneven tire wear.

Any excessive or abnormal tire wear may indicate worn or misaligned suspension or steering, unbalanced tire or other tire/suspension problem.

Alignment can be affected by worn steering/suspension parts or by incidents which happen during driving, such as hitting a curb, pothole or railroad track, etc. Improper alignment can cause tires to roll at an angle and wear unevenly. It may also cause the vehicle to "pull" to the right or left. Have your dealer inspect your vehicle's suspension and steering components periodically for misalignment or wear.

Out-of-balance tires will not roll smoothly and can lead to annoying vibrations and uneven tread wear such as cupping and flat spots. Tires may need to be balanced if uneven wear is detected or if ride comfort decreases noticeably.

### **CARE OF OPTIONAL ALUMINUM WHEELS**

If your aluminum wheels should become dull or discolored by road film, use any commercially available designated aluminum wheel cleaner-polish to restore the bright finish. The wheel manufacturer suggests monthly cleaning during constant daily use and less frequently with decreasing use.

### **REAR AIR SPRINGS**

Some models may be optionally equipped with pneumatic air bag rear helper springs. The fill valve(s) for these springs are located on the valance panel, near the rear tires, on either side of the vehicle.

Air pressure must be maintained at a minimum of 30 psi and a maximum of 90 psi. Detailed information regarding adjustment of air springs is provided in your Motor Home Operation Manual binder.

### **REAR SUSPENSION INFORMATION (Models Equipped with Tag Axle Only)**

Some models are equipped with an independent, torsion sprung, tag axle that helps to minimize body roll, leaning and rear end sag.

### **In Case of Temporary Traction Loss**

Should an uneven surface (such as a driveway entry) cause the drive wheels to lose contact with the drive surface, you may experience a momentary loss of mobility. In this event, remove your foot from the accelerator and allow approximately 8-12 seconds for the axle system to adjust itself and restore traction.

**NOTE:** If the distance from the drive wheels to the drive surface is beyond the adjustment capability of the system, towing assistance may be required.

### **Compressor Operation**

The compressor, which is located under the lavatory area, will operate periodically to maintain pressure in the air reserve tank. A brief "hiss" sound may be heard as the compressor stops and when the ignition is switched off. This is a normal pressure bleed-off function of the compressor and is no cause for alarm.

**NOTICE:** Before starting the engine after any extended period of storage or non-use, we recommend that you pre-fill the tag axle suspension system with air. This will save "wear and

tear" on the air compressor by reducing initial operating time.

To do this, add air through the valve on the air tank with a standard (tire) air chuck.

Fill the tank to 100 psi maximum, measured using a tire gauge on the fill valve. Then, start the vehicle to allow the system to equalize itself automatically.

### **Moisture Purging**

The air tank is mounted on the underside of the vehicle between the rear axles and the fuel tank. A drain valve is mounted on the bottom of the air tank to allow you to purge the condensation that normally forms on the inside of the tank.

The valve is operated by pulling a metal ring on a cable which is attached to the valve. The ring is suspended from the chassis rail near the sewage dump valves on the rear left side of the vehicle.

To purge moisture from the air tank, pull on the metal ring momentarily and release repeatedly until water is no longer seen spraying from the valve on the bottom of the tank. This operation should be performed weekly during periods of normal use.

### **CAUTION**

The LOW AIR warning light, located on the instrument panel, will illuminate if a failure should occur in the tag axle/rear suspension system. If this should occur while driving, the vehicle may be carefully driven to the nearest Winnebago dealer or a qualified truck air suspension service center. Although this condition does not totally disable the vehicle, it will cause less than satisfactory ride characteristic and should be serviced as soon as possible to restore proper performance.

### **Lubrication and Maintenance**

The tag axle bearings require annual and periodic maintenance as described below to ensure maximum performance and durability. Service is required at more frequent intervals under severe operating conditions.

## CAUTION

Failure to correctly maintain proper lubrication in the bearings may result in bearing damage, which could cause the wheel to seize or become detached during operation.

**Periodically**—Using a manual grease gun, add 2-3 strokes of lithium base wheel bearing grease through the zerk fitting in the center of the tag axle bearing dust caps. This should be performed at regularly scheduled intervals, such as oil changes or chassis lubrications.

**Yearly**—Bearing components should be inspected at each 12,000 miles or at least annually, especially when returning vehicle to service after storage periods, to ensure that no abnormal wear or bearing setting has resulted. Repack bearings, cups and dust covers with lithium base wheel bearing grease and reinstall assembly. Due to the critical nature of wheel bearing adjustment, we recommend that this operation be performed by your dealer.

## WINDSHIELD WASHERS AND WIPERS

See your vehicle chassis manual for recommendations and precautions regarding washers and wipers.

## COLOR-KEYED BUMPER SHELLS

**Front**—Elandan/Windcruiser/Sunflyer  
**Rear**—Elandan/Windcruiser

## CAUTION

Do not stand on or mount objects to the front bumper shell. This could cause damage to the appearance of the plastic shell.

The bumper is equipped with a color keyed shell made of high-impact ABS plastic. Standing on the bumper, however, to wash the windshield or to perform other services is not recommended.

## LIGHTS

All exterior lights should be checked for proper operation each time the vehicle is prepared for a trip. Any bulbs which fail to light should be checked and replaced, when necessary, with a new bulb of the same size. A failure of more than one light, such as both taillights not operating, may indicate a burned-out fuse. Check fuse and replace with one of the same rating when necessary. If a fuse is not the cause of the problem, the wiring system should be checked immediately by an authorized service center.

The headlight circuit is protected by a circuit breaker. An overload on the breaker will cause the lights to flicker on and off. Headlight wiring should be checked immediately anytime this condition is apparent. Refer to your vehicle chassis manual for further information.

## AUTOMOTIVE 12-VOLT FUSES

The automotive electrical circuits are protected from short circuit and overload conditions by a fuse block. On most models, this is located beneath the dash to the left side of the steering column. See your vehicle chassis manual for additional fuse replacement information.

**Chieftain and Sunflyer models** have a circuit breaker panel located under the hood on the driver side firewall. Each pop-out breaker is labeled according to the circuit it protects.

OCT 31 1983

# SECTION 11

## STORING YOUR MOTOR HOME

### PREPARING VEHICLE FOR STORAGE

#### STORING

Properly preparing your vehicle for storage will lessen the possibility of damage to your vehicle. Prepare the motor home for vacancy just as you would if you were leaving your house for an extended period:

- Remove all perishables from cabinets and refrigerator.
- Prop refrigerator door open.
- Turn off LP gas tank.
- Drain water heater, water tank and holding tank.
- Close shades to protect upholstery from sunlight.

When storing your vehicle through the winter, or in cold climates, extra preparations need to be made to protect systems that can be damaged by freezing temperatures.

#### Cold Weather Storage Procedure

1. Have the vehicle chassis completely serviced and lubricated. Be sure radiator antifreeze protection level is sufficient for the lowest possible temperature.
2. Wash and wax the vehicle.
3. Inspect sealants around windows, vents, body joints, etc. and replace as necessary. Proper sealant materials are available from your dealer.
4. Close all windows and roof vents. Seal all appliance vent openings.
5. Clean the entire interior of the coach. Dirt and stains are more easily removed when fresh.
6. Remove all foods and equipment that may cause odors.
7. Clean and defrost refrigerator. Leave door slightly ajar to allow any odors to dissipate.
8. Level the motor home and drain the complete plumbing system as described in the following steps.
9. Open the water system drain valves. Pull up on ring to drain. Refer to Plumbing section for drain valve locations.

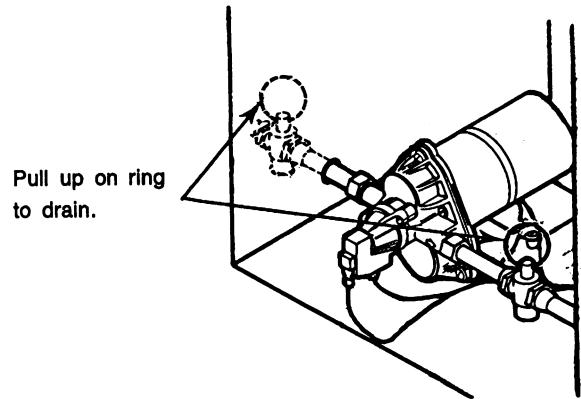

10. Open all faucets including the shower head valve.
11. Allow demand water pump to operate until all water lines have been drained.
12. With water pump running, operate toilet flush mechanism and hold until water stops flowing.

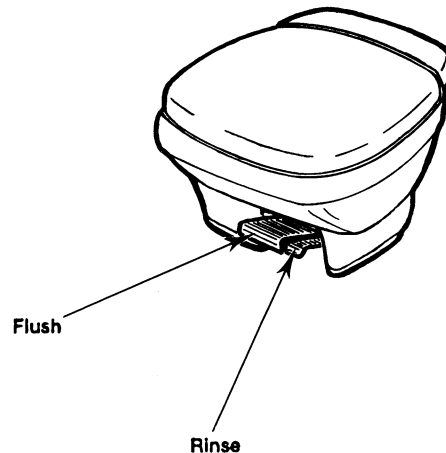

13. Drain water heater by opening drain valve located at base of water heater tank, accessible from the outside of the motor home. Also open the pressure relief valve, located at the top right portion of the tank. This will assist in draining and prevent air locking in the tank.

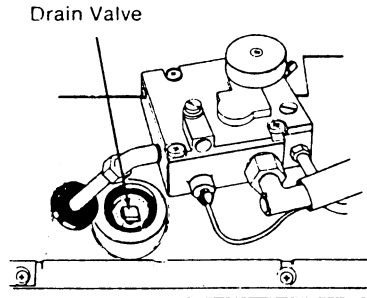

**Water Heater Drain Valve**

### CAUTION

Turn off the water heater power switch before draining the tank to avoid damage to the heater.

14. After water has stopped draining at all faucets and valves, use a hand pump or service station air hose at the city water connection to force air through the water system.

### CAUTION

To avoid possible damage to the pump or water lines, limit air pressure to 30 psi.

15. Disconnect discharge and intake water lines from demand water pump. Start pump and allow to run until all water has been expelled from the unit. (Running dry will not harm the pump.) Then reconnect the lines.

**NOTE:** As an alternative to system draining, all tanks and lines may be winterized with the use of non-toxic RV antifreeze added to the storage tank and pumped throughout the system. Follow the directions on the container to determine the correct amount of antifreeze to be used.

16. Pour non-toxic RV antifreeze into bathroom sink drain, shower drain and kitchen sink drain. See container label for amount.

## WARNING

Do not use automotive-type radiator antifreeze. It is poisonous.

17. Completely drain the sewage holding tank. Thoroughly rinse tank and drain again. It is recommended that, when rinsing the tank, you make sure all material has been loosened. Close the dump valve and replace cap to prevent the dump valve shaft from rusting and to prevent rodents from entering the tank.
18. Turn furnace thermostat to "OFF" position.
19. Lubricate all hinges and door locks.
20. Fully charge all batteries.
21. Disconnect chassis battery cables.
22. Disconnect all auxiliary battery cables or turn off Auxiliary Battery Disconnect Switch if equipped.
23. Check battery charge once a month. Recharge if necessary.
24. Preparing the toilet:
  - disconnect water line at ball valve
  - depress foot pedal of toilet and insert an object, such as a wedge-shaped block of wood, into outlet at bottom of bowl.
  - slowly release pedal until blade touches and holds object.

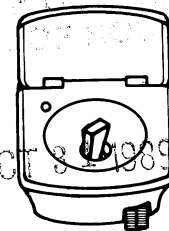

### IMPORTANT

Avoid using items small enough to drop through outlet into tank.

It is also important that you wash the exterior of your motor home before storing it. After washing the motor home, carefully inspect seams and seals around doors, window frames,

vents and any other joints for leaks. Repairing damaged seals or seams is not difficult. Sealing compounds can be purchased from your dealer. Excessively damaged weather seals may need to be replaced by your dealer.

### **REMOVAL FROM STORAGE**

1. Completely air out the motor home.
2. Have the entire LP gas system checked for leaks.
3. Check window operation.
4. Check cabinet and door hinges. Lubricate with penetrating oil, if necessary.
5. Close all faucets and drain valves that are open. If necessary, reconnect toilet water line and close flush valve.
6. Add a few gallons of water to the fresh water tank and check for leaks especially at junctions. Also make sure all hangers and supports are securely in place. Sanitize the water system as outlined under "Disinfecting the Fresh Water System" in Section 7.
7. Check operation of all faucets to be sure faucet washers have not hardened during storage.
8. Check sealing valve in the toilet for proper operation and lubricate with silicone spray.
9. Add water to the holding tank using the toilet flush pedal. Check to be sure dump valve seals tightly.
10. Check around all appliances for obstructions and ensure that all vent openings are clear.
11. Start refrigerator and check for proper cooling.
12. Clean paneling and counter surfaces and apply a thin coat of wax.
13. Replace batteries if necessary and check out electrical system to make sure all lights and electrical components operate.
14. Check tires for proper cold inflation pressure.
15. After washing accumulated winter grime from the vehicle, it is important to carefully inspect the seams and sealants for separation or cracks that may have appeared around the window frames, vents and any other joints. Re-sealing is quite simple and the material is quickly and easily applied. Appropriate compounds are available from your Winnebago/Itasca dealer. Also, inspect weather seals around doors, etc., and if necessary, have a dealer replace immediately.

## INDEX

- A**
- Air Conditioner . . . . . 2-20, 8-11
  - Air Horns . . . . . 2-22
  - Air Springs, Rear . . . . . 10-5
  - Aluminum Wheels, Care of . . . . . 10-5
  - Antenna and Signal Amplifier . . . . . 8-11
  - Arm Rest Adjustment . . . . . 2-5
  - Audio System—Radio/Cassette . . . . . 2-20
  - Auxiliary Generator 110-Volt . . . . . 6-4
  - Auxiliary Generator Hourmeter . . . . . 6-5
- E**
- Electrical Outlets, 110-Volt . . . . . 6-3
  - Electrical Safety Precautions . . . . . 1-2
  - Electrical System, 110-Volt AC . . . . . 6-1
  - Electrical System, 12-Volt DC . . . . . 6-5
  - Emergency Brake (Hand Brake) . . . . . 2-2
  - Emergency Equipment Checklist . . . . . 4-3
  - Emergency Exit Window . . . . . 1-4
  - Engine Access . . . . . 10-4
  - Engine Cooling System . . . . . 10-4
  - Engine Overheat . . . . . 3-5
  - Engine, Starting and Stopping the . . . . . 2-2
  - Entering Your Vehicle, Before . . . . . 2-1
  - Exterior Body Care . . . . . 10-1
  - Exterior Feature Identification . . . . . vii
  - External Power Cord (Shoreline) . . . . . 6-1
- F**
- Fan Switch, Auxiliary Defrost . . . . . 2-22
  - Faucet O-Rings, Washerless . . . . . 10-3
  - Fire Extinguisher . . . . . 1-5
  - Flooring . . . . . 10-3
  - Formaldehyde Warning . . . . . 1-4
  - Fuel Caps, Replacement . . . . . 2-2
  - Fuel Economy Gauge, Vacuum . . . . . 2-21
  - Fuel Pump Shut-Off Switch . . . . . 2-3
  - Fuel Selection, Vehicle . . . . . 2-2
  - Fuel Safety Precautions . . . . . 1-1
  - Fuel Tank, Filling Vehicle . . . . . 2-2
  - Furnace, LP Gas . . . . . 8-11
  - Fuses, 12-Volt . . . . . 6-5, 10-6
- G**
- General Warnings . . . . . 1-1
  - Generator, Auxiliary 110-Volt . . . . . 6-4
  - Generator Hourmeter . . . . . 6-5
  - Ground Fault Circuit Interrupter (GFCI) . . . . . 6-4
- H**
- Hazard Flashers . . . . . 2-3, 3-1
  - Hand Brake . . . . . 2-2
  - Heater/Defroster . . . . . 2-19
  - Heater, Rear Auto . . . . . 2-20
  - Holding Tank, Dumping . . . . . 7-4
  - Holding Tank Level Indicators . . . . . 7-5
  - Hood, Engine . . . . . 10-4
  - Horn, Air . . . . . 2-22
  - Hourmeter, Auxiliary Generator . . . . . 6-5
  - Hydraulic Leveling System . . . . . 2-22
- I**
- Instrument Panel Diagram . . . . . 2-(9-15)
  - Instrument Panel, Electronic . . . . . 2-16
  - Interior Care . . . . . 10-1
- J**
- Jump Starting . . . . . 3-4
- K**
- Keys . . . . . 2-2
- L**
- Leveling Systems, Coach . . . . . 2-22
  - Light
    - Aisle Floor . . . . . 2-22
    - Beverage Tray . . . . . 2-21
    - Courtesy . . . . . 2-21
    - Map . . . . . 2-21
  - Lights, Replacing Interior . . . . . 10-6
  - Loading, Roof . . . . . 4-1
  - Loading Safety Precautions . . . . . 1-3
  - Loading the Vehicle . . . . . 4-1
  - Locks . . . . . 2-3
  - Locks, Power Door . . . . . 2-4
  - LP Gas Furnace . . . . . 8-11
  - LP Gas Leak Gauge . . . . . 1-2, 5-4
  - LP Gas Leaks . . . . . 1-2, 5-4
  - LP Gas Pressure Regulator . . . . . 5-3
  - LP Gas Safety Precautions . . . . . 1-1
  - LP Gas Selection . . . . . 5-1
  - LP Gas System, Safe Use of . . . . . 5-1
  - LP Gas Tank . . . . . 5-2
  - LP Gas Tank, Air in the . . . . . 5-2
  - LP Gas Tank Filling . . . . . 5-2
  - LP Gas, Traveling with . . . . . 5-2
  - LP Gas, Winter Use of . . . . . 5-5
  - LP Gas Works, How . . . . . 5-1
- M**
- Map Light . . . . . 2-21
  - Microwave Oven . . . . . 8-8
  - Mirrors, Rear and Side View . . . . . 2-7
  - Monitor Panel . . . . . 8-8
  - Motor Home Operations Manual (Binder) . . . . . iv
  - Motor-Aid Water Heater . . . . . 8-10
  - Mountain Driving . . . . . 4-5
  - Multi-Function Signal Lever . . . . . 2-16
- N**
- Nighttime Driving . . . . . 4-5
- O**
- Operators Manual . . . . . iv
  - Outlets, 110-Volt . . . . . 6-3
  - Oven . . . . . 8-6
  - Oven, Microwave . . . . . 8-8
  - Oven Pilot . . . . . 8-7
  - Overheated Engine . . . . . 3-5
- P**
- Parking Brake (Emergency Brake) . . . . . 2-2
  - Power Roof Vent . . . . . 9-3
  - Power Converter Location, 110V-to-12V . . . . . 6-2
  - Pre-Travel Checklist . . . . . 4-3
  - Pressure Regulator (LP Gas) . . . . . 5-3
  - Pump Switch, Water . . . . . 8-8
- Q**
- Quick Load Checklist . . . . . 4-3
- R**
- Radio Switch . . . . . 2-20
  - Range . . . . . 8-6
  - Range Hood . . . . . 8-8
  - Range Maintenance . . . . . 10-2
  - Refrigerator . . . . . 8-1
  - Refrigerator Maintenance . . . . . 10-2
  - Regulator, LP Gas . . . . . 5-3

Relief Valve, Water Heater	8-10
Removal From Storage	11-3
Restraints, Child	2-7
Roof Loading	4-1
Roof Maintenance	10-1
Roof Vent, Power	9-3

## S

Seat Belts and Child Restraints	2-7
Seat Belts	2-6
Seat, Power Co-Pilot	2-6
Seats	2-5
Service and Assistance	v, 10-4
Sewer Systems (Hook-up)	7-5
Shade Adjustment	10-3
Shoreline Power Cord (Hook-up)	6-1
Shower Valve Pressure Bleed-Off	7-4
Signal Lever, Multi-Function	2-17
Sink, Fold-Up Lavatory	9-2
Sink, Stainless Steel	10-2
Smoke Alarm	1-5
Spare Tire	3-1
Speed Control	2-17
Springs, Rear Air	10-5
Starting and Stopping the Engine	2-3
Step, Manual	2-4
Step, Powered	2-4
Storage, Removal From	11-3
Storing, Cold Weather	11-1
Storing, Motor Home	11-3
Suspension Alignment	10-4
Suspension Information, Rear	10-5

## T

Tables	10-2
Thermal Breaker, Power Converter	6-3
Thermostat, Front A/C	8-11
Tires	10-4
Tire Balance	10-4
Tire Changing	3-2
Toilet	9-2
Towing Your Vehicle	3-3
Trailer Towing	4-1
Travel Tips	4-3
TV Antenna	8-11
TV Signal Amplifier	8-11

## U

Upholstery Carpeting and Draperies	10-1
Under-body Cleaning	10-1

## V

Vacuum-Fuel Economy Gauge	2-21
Vehicle Chassis Manual	iv
Vehicle Certification Label	vi
Vent, Power Roof	9-2
Vinyl Fabrics	10-2

## W

### Warnings

Carbon Monoxide	1-4
Driving	1-1
Electrical	1-3
Formaldehyde	1-4
Fuel	1-1, 2-2
General	1-1
Generator, Auxiliary	6-4
LP Gas	1-1, 5-1
Loading	1-3
Maintenance	1-3
Warranty	v
Washerless Faucet O-Rings	10-3
Waste Drainage System	7-4
Water Pump	7-2
Water Pump Switch	8-8
Water Heater	8-9
Water Heater, Motor-Aid	8-10
Water Heater Relief Valve	8-10
Water Hook-Up, External	7-3
Water Hook-Up, Flushing	7-3
Water, Shower Valve Bleed-Off	7-4
Water System, Disinfection of	7-2
Water System, Fresh	7-1
Water Tank, Filling Instructions Fresh	7-1
Water Tank, Draining	7-1
Water Tank, Preparing for Storage	7-2
Water Tank Power Drain	7-4
Water Tank Power Drain Valve Locations	7-4
Water Tank Storing	7-2
Weather Information, Severe	4-4
Weighing the Vehicle	4-1
Wheel Nuts	3-3
Window Cleaning	10-3
Window Shades	10-3
Windows, Crank-Out	9-4
Windows, Power	2-4
Windshield Wiper/Washer	10-6
Windshield Wiper/Washer Switch	2-16
Winnebago-Itasca Travelers Club (WIT)	i



# IMPORTANT SERIAL NUMBERS

**Motor Home (Coach):** Year \_\_\_\_\_ Model \_\_\_\_\_ Serial \_\_\_\_\_

**Chassis:** Make \_\_\_\_\_ Serial (VIN) \_\_\_\_\_

**Front Air Conditioner:** Brand \_\_\_\_\_ Model \_\_\_\_\_ Serial \_\_\_\_\_

**Rear Air Conditioner:** Brand \_\_\_\_\_ Model \_\_\_\_\_ Serial \_\_\_\_\_

**Furnace:** Brand \_\_\_\_\_ Model \_\_\_\_\_ Serial \_\_\_\_\_

**Water Heater:** Brand \_\_\_\_\_ Model \_\_\_\_\_ Serial \_\_\_\_\_

**Power Converter:** Brand \_\_\_\_\_ Model \_\_\_\_\_ Serial \_\_\_\_\_

**110-Volt Generator:** Brand \_\_\_\_\_ Model \_\_\_\_\_ Serial \_\_\_\_\_

**Range:** Brand \_\_\_\_\_ Model \_\_\_\_\_ Serial \_\_\_\_\_

**Microwave Oven:** Brand \_\_\_\_\_ Model \_\_\_\_\_ Serial \_\_\_\_\_

**Refrigerator:** Brand \_\_\_\_\_ Model \_\_\_\_\_ Serial \_\_\_\_\_

**Television:** Brand \_\_\_\_\_ Model \_\_\_\_\_ Serial \_\_\_\_\_

**Video Cassette Player:** Brand \_\_\_\_\_ Model \_\_\_\_\_ Serial \_\_\_\_\_

## EMERGENCY INFORMATION

**Dealer**

Name \_\_\_\_\_

Address \_\_\_\_\_

Phone \_\_\_\_\_

**INSURANCE POLICY**

Company \_\_\_\_\_

Policy Number \_\_\_\_\_

Phone \_\_\_\_\_

STATE OF CALIFORNIA  
DIRECTOR OF REVENUE

OCT 31 1989





